

# Amphe-Power<sup>®</sup> Connectors with RADSOK<sup>®</sup> Technology

SL-391-4

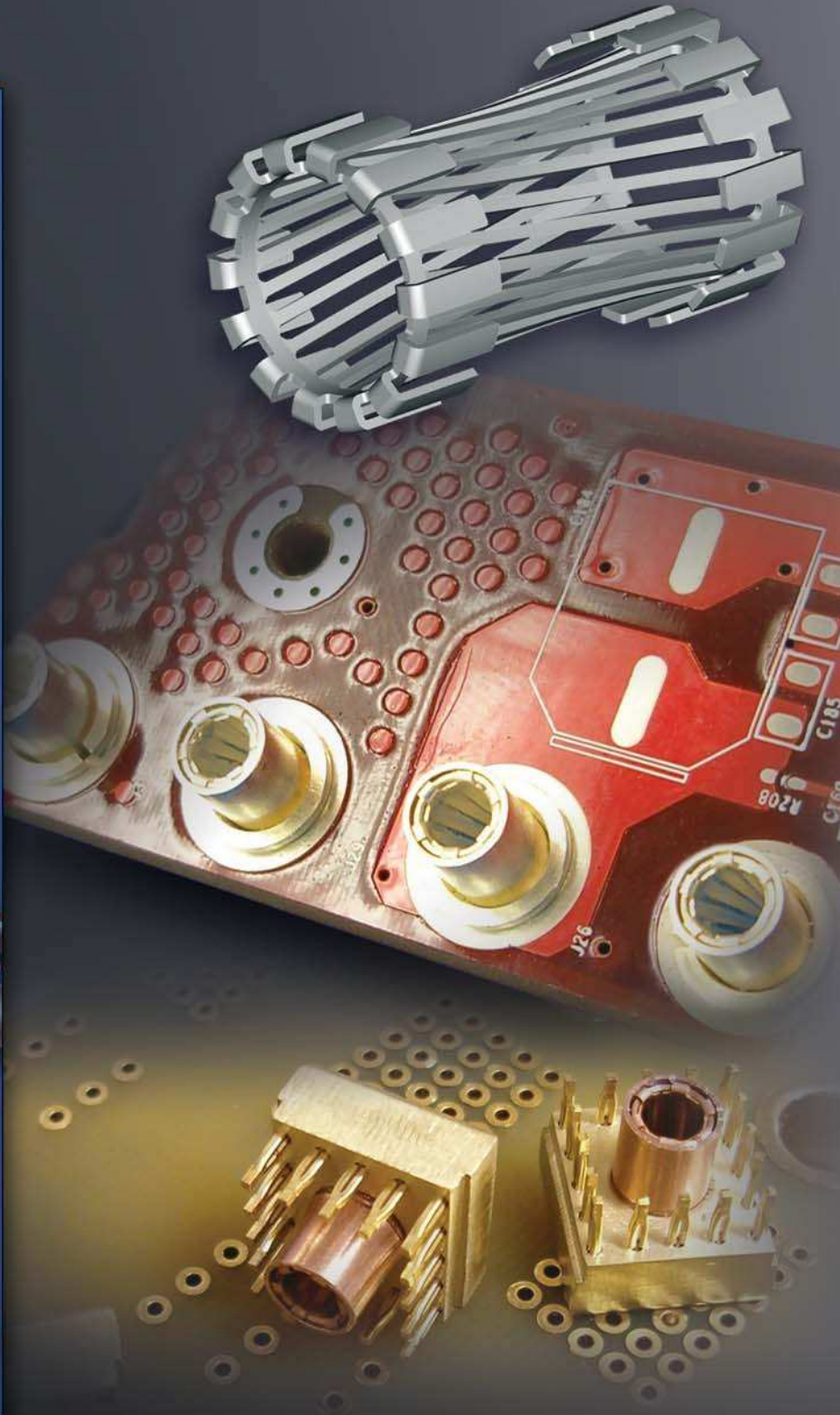

# Amphenol

# RADSOK® Technology Advantages

## TABLE OF CONTENTS

	Page Number
RADSOK® Technology Advantages/ Interconnect Solutions for the Power Bus Market.....	Inside Covers
The Amphe-Power® Family of Connectors For High Power Applications .....	1
Amphe-Power® P-Lok Connector Styles .....	2
Amphe-Power® 5015 Connector Styles .....	3
Amphe-Power® GT Connector Styles .....	4 - 5
RADSOK® Layouts .....	6 - 10
Amphe-Power® P-Lok Part Numbering .....	11
Amphe-Power® 5015 Part Numbering .....	11
Amphe-Power® GT Part Numbering .....	12
Amphe-Power® Composite Amphe®-GTR Connectors .....	13
Amphe-Power® GT Connectors with TUV Finger Proof .....	14
Amphe-Power® P-Lok Connectors 14mm RADSOK® Sockets, 500 Amps Rating ....	15
Amphe-Power® Last Mate - First Mate P-Lok Connectors .....	16
Amphe-Power® Amph-BU™ Connectors .....	17
Power to Board Interconnects .....	18
RADSOK® PowerBus Products:	
Amphe-PD™ Connectors .....	19
Amphe-PD™ Bridge, RADLOK™ Connectors .....	20
PowerBlok™, RADSSERT™ Connectors ....	21
PGY™, Busbars, RADSOK® with Flex .....	22
SurLok™ Compression Lugs with Plastic Housings Utilizing RADSOK® Technology .....	23
Amphe-Base™, Amphe-Com™, HiLok™ Connectors .....	24
Amphe-Y™, Amphe-Armor™, Tru-Loc™ Connectors .....	25
More Amphenol® RADSOK® PowerBus Products: .....	26

- **HIGH RELIABILITY**

Unique RADSOK® design and construction technology create an electrical contact interface that exceeds typical interconnect requirements. Applications in aerospace, medical, industrial, automotive, mining, offshore, and other harsh environments depend on high reliability of the Amphenol RADSOK® technology.

- **LOW CONTACT ENGAGEMENT/SEPARATION FORCES**

The hyperbolic lamella socket contact construction distributes normal forces over a high percentage of the mating pin surface. This creates a smooth, even engagement effort. This force distribution also contributes to excellent performance in vibration applications with resistance to typical fretting corrosion.

- **LOW CONTACT RESISTANCE**

The large interface area between the socket lamella and pin surface result in very low contact resistance, enabling the RADSOK® contacts' high current ratings compared to traditional power contact designs.

- **HIGH MATING CYCLE DURABILITY**

RADSOK® contacts with typical silver plating finishes have demonstrated survival of 20,000 mating cycles. Specialized plating and contact lubricants can extend cycle life to 200,000 matings or higher. Even with continuous exposure to harsh environmental abuse (salt, sand, and high humidity), RADSOK® contacts have been tested to maintain low contact resistance beyond 10,000 mating cycles.

## RADSOK® Derating Chart – Temperature vs. Current

Based on single conductors in free air. Wire cross-section same size as pin contact cross-sectional area.

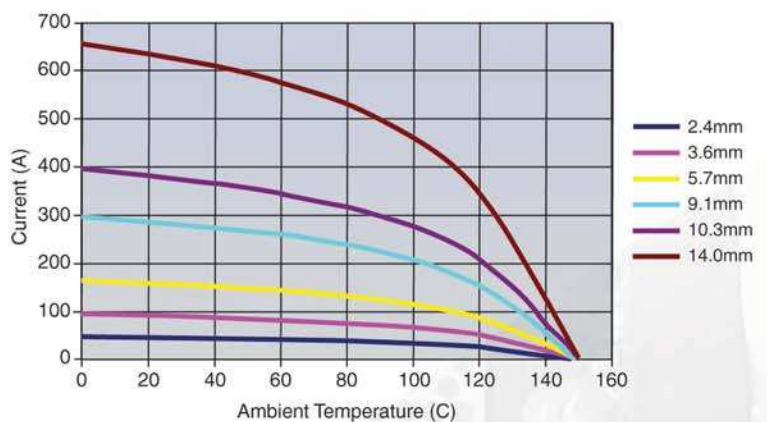

For more information on RADSOK® products from Amphenol:  
[www.amphenol-industrial.com](http://www.amphenol-industrial.com) and [www.radsok.com](http://www.radsok.com)  
 Contact Amphenol Industrial Operations, Sidney, NY  
 (Phone: 607-563-5011) or Amphenol Power Solutions, Fraser, MI  
 (Phone: 586-294-7400)



# RADSOK® Interconnect Solutions for the Power Bus Market

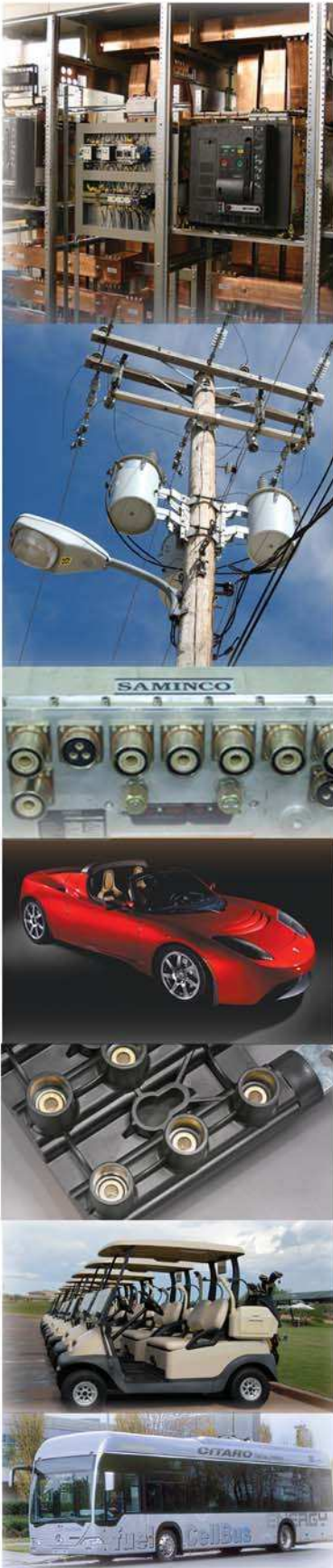

## The Wide Variety of RADSOK® Applications include:

- Replacement of ring terminals (lugs) on threaded studs
- High current PCBs
- Communication towers
- Backplane power
- Uninterrupted power supplies
- Fuel cell connectors
- Hybrid electric vehicles (example right is the Tesla Hybrid Car; photograph shown by permission of Tesla)
- AC inductive drive motors
- Power distribution modules
- Busbar terminations (plug-in hardware/modules)
- “Pluggable” breakers
- Battery terminals
- Existing Amphenol products: 5015, GT, ACA-B, P-Lok or replace other manufacturers’ connectors
  - contacts with RADSOK® technology give 50% more ampacity.
- RADSOK® contacts can be designed to fit any housing
- Developing Military applications of RADSOK® technology
  - combinations of RADSOK® and high speed copper contacts in the same interconnect package

## Standard and Custom-Developed Solutions

- In addition to the various standard sizes of RADSOK components, custom-developed solutions are also available. See the new RADSOK® products that have been developed on the special pages at the end of this brochure. Amphenol has the global design, engineering and manufacturing resources to provide RADSOK® sockets pressed into busbars, crimped to cables, assembled into connectors, assembled into customer or Amphenol designed specialized electrical devices, or as stand-alone components. Amphenol also manufactures a full compliment of mating pin contacts for any application.
- Steady-state current capacities for standard RADSOK products range from 50 amps to over 1000 amps.
- Standard contact plating is typically Silver (Ag) although many other plating specifications may be used for your application.
- Amphenol connectors with RADSOK® contacts are offered with a variety of positive-locking features (HiLok™ and SurLok™) that insure and maintain fully-mated connections.
- Sealing (Sealtac™) and high voltage hot break options are available within the RADSOK® itself or within a very wide range of IP rated connector housings to provide environmental protection to the contact area.

**Amphenol Industrial operates a Quality System that is third-party certified to ISO9001:2000 and AS9100.**

# The Amphe-Power® Family of Connectors For High Power Applications

The Amphe-Power® Series consists of three of the time-tested and reliable families of Amphenol Industrial Connectors, all of which are MIL-5015 styles, medium to heavy duty cylindricals. These series, enhanced with RADSOK® sockets, can now handle up to 50% higher amperages. Current Amphe-Power® product lines support from 50A to 1000A continuous duty.

## AMPHE-POWER® P-LOK



- Rapid mating with a push-pull, spring loaded coupling system - audible & tactile confirmation of full mating.
- Environmental sealing to IP67 specification levels - front and rear O-ring seals and gaskets as well as compression grommets designed to seal on the cable jacket.
- Neoprene inserts are bonded to the connector shell for ease of assembly.
- One piece keyed aluminum shell, finished in black hard-coat plating - provides a strong industrial grade connector, engineered for a long service life.

AMPHE-POWER®  
SPECIAL  
P-LOK DESIGNS



First Mate,  
Last Break  
P-Lok Style



Power P-Lok  
14mm Style for  
Higher Amperage

## AMPHE-POWER® GT



- Reverse bayonet coupling connector with an audible, tactile and visual full mating feature.
- Heavy duty, rugged shells with a wide variety of backshell options.
- Inserts available in Neoprene or Viton.
- Waterproof construction and available with over-molded coupling nut for added damage protection and increased gripping surface.
- Variety of plating options including non-cadmium zinc cobalt (black or green), non-conductive colorized anodic plating.

AMPHE-POWER®  
SPECIAL  
GT DESIGNS



Amphe-Power  
GT with  
TUV "Finger-Proof"  
Feature



Amphe-Power  
Composite GTR

## AMPHE-POWER® 5015



- Durable, field proven cylindrical connector derived from MIL-5015 family.
- Threaded coupling connector with resilient Neoprene inserts, single key/keyway polarization.
- Styles include: solid shell for general, non-environmental applications; pressurized style for use on pressurized bulkheads or pressure barriers; environmental resisting style with strain relief; lighter weight and shorter environmental resisting style.

**AMPHE-POWER® P-LOK CONNECTOR STYLES**

The P-Lok Heavy Duty Series offers a wide range of shell styles which can be enhanced with RADSOK high amperage contacts

**WALL MOUNT OR FLANGE MOUNT RECEPTACLES**

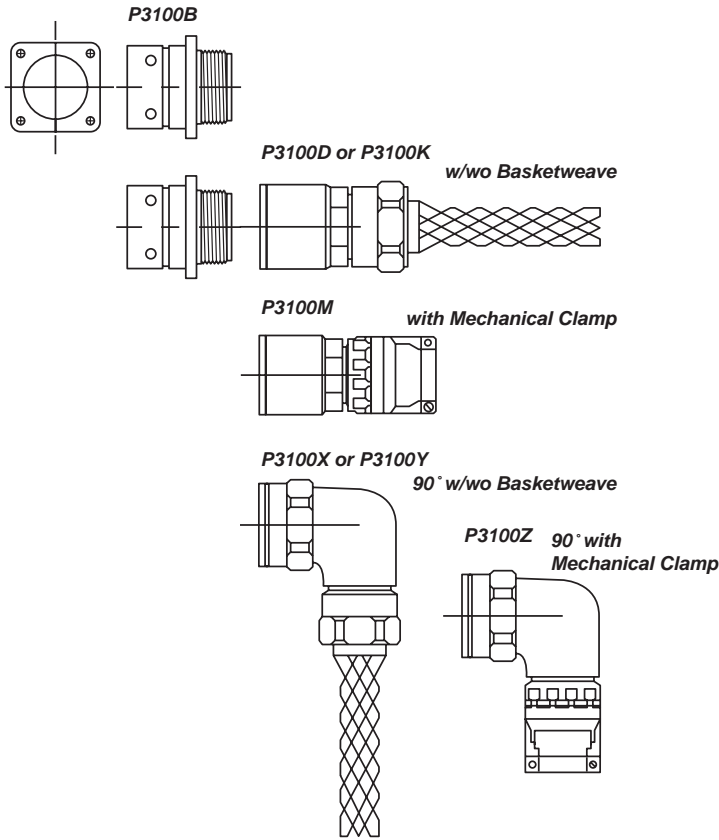

**INLINE RECEPTACLES**

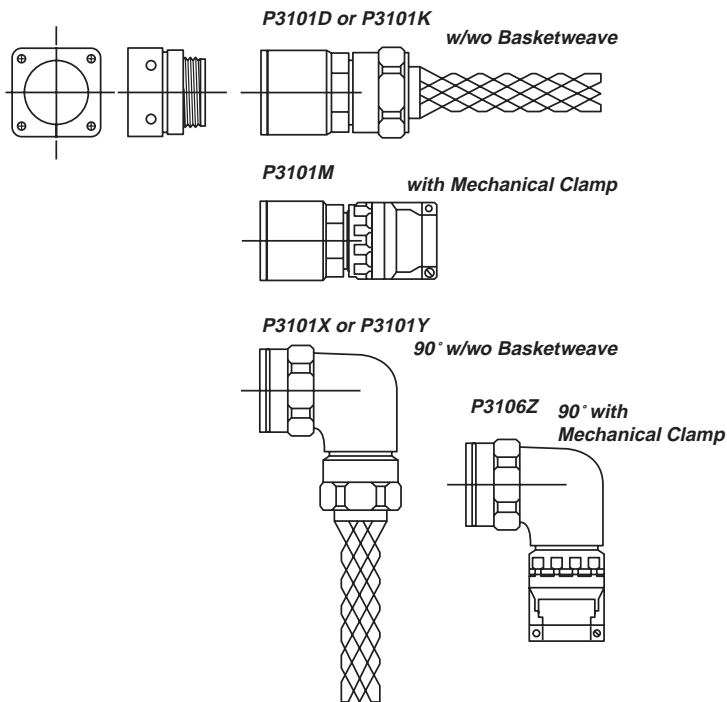

**PLUGS**

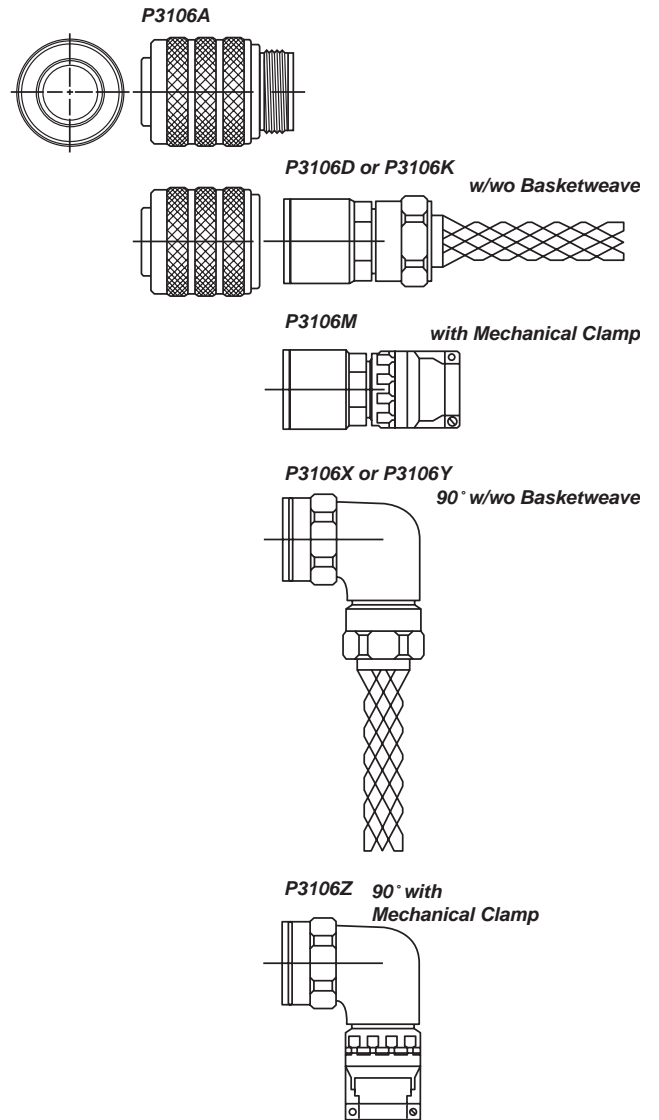

**BOX MOUNT RECEPTACLES**

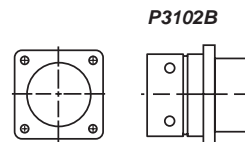

For complete dimensional information on P-Lok Series connector styles, consult Amphenol/Pyle P-Lok Catalog.

# AMPHE-POWER® 5015 CONNECTOR STYLES

The 5015 Standard Cylindrical Series offers a wide range of shell styles which can be enhanced with RADSOK high amperage contacts

## WALL MOUNT RECEPTACLES

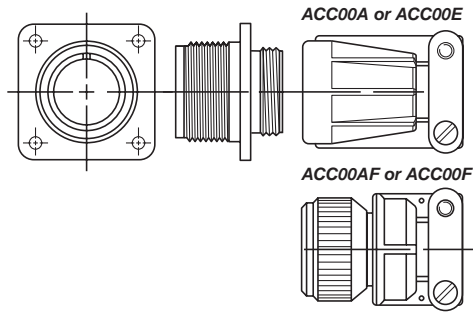

## BOX MOUNT RECEPTACLES

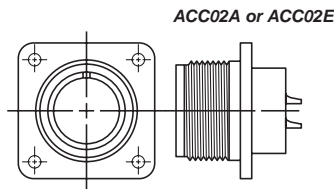

## INLINE RECEPTACLES

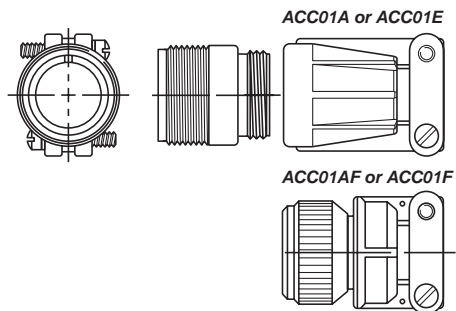

## 90 DEGREE PLUGS

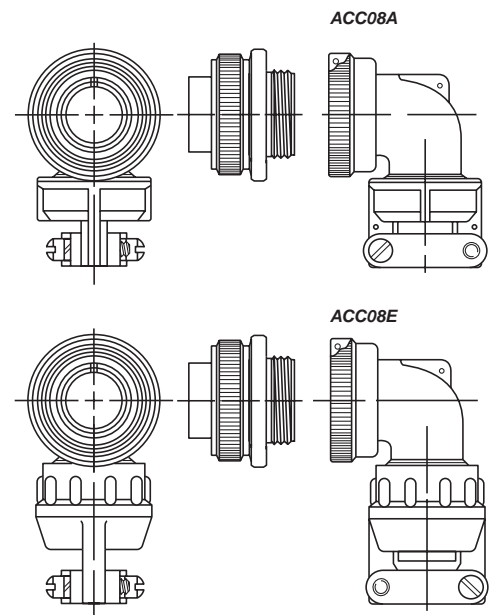

## STRAIGHT PLUGS

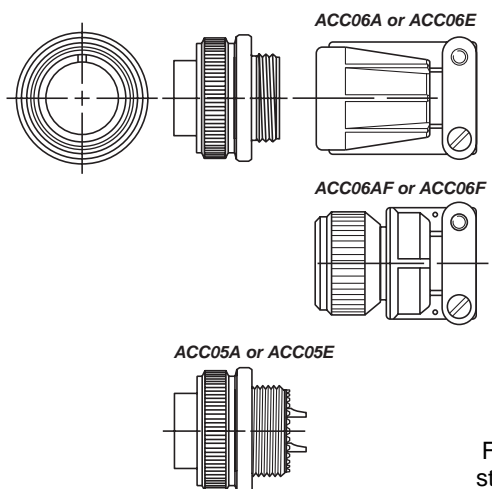

For complete dimensional information on 5015 connector styles, consult Amphenol AC Catalog 12-025.



**AMPHE-POWER® GT CONNECTOR STYLES**

The GT Reverse Bayonet Series offers a wide range of shell styles which can be enhanced with RADSOK high amperage contacts

**WALL MOUNT RECEPTACLES  
FOR FRONT PANEL MOUNTING**

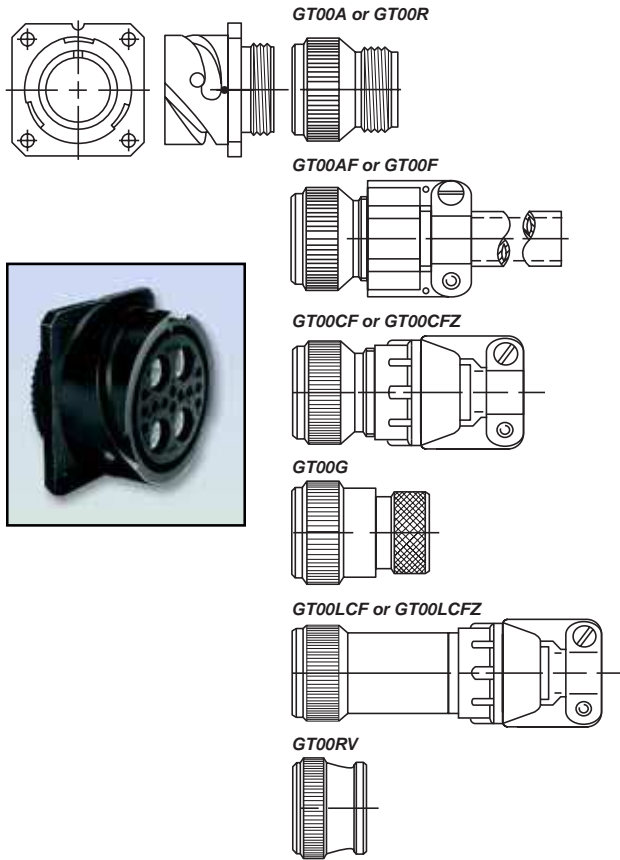

**BOX MOUNT RECEPTACLES  
FOR FRONT PANEL MOUNTING**

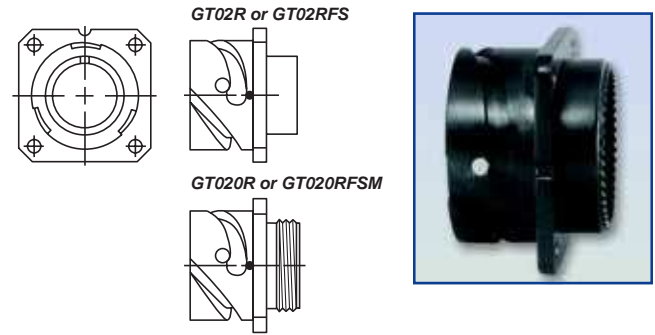

**JAM NUT RECEPTACLES**

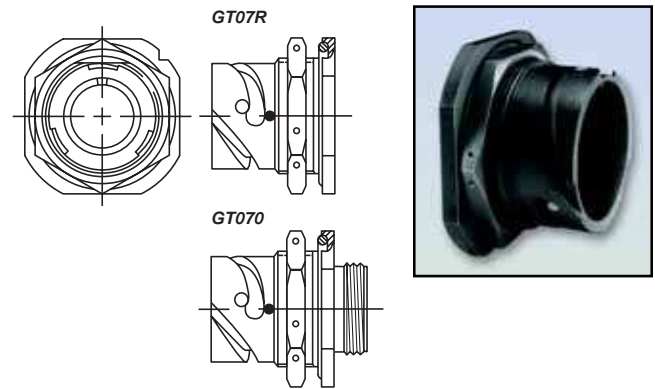

**INLINE RECEPTACLES**

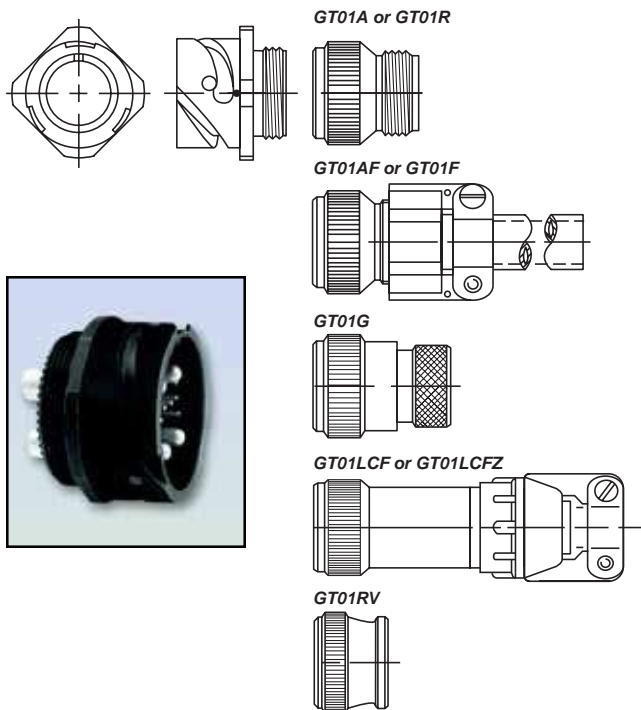

**SQUARE FLANGE RECEPTACLES  
FOR REAR PANEL MOUNTING**

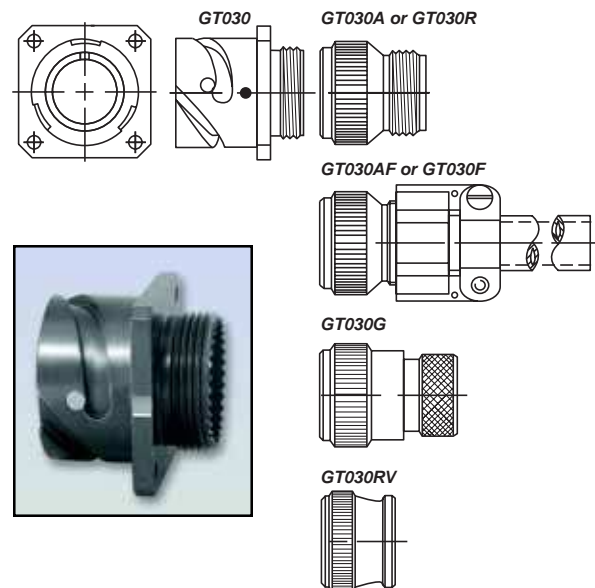

For complete dimensional information on GT Series connector styles, consult Amphenol catalog 12-024.

# AMPHE-POWER® GT CONNECTOR STYLES, CONT.

## STRAIGHT PLUGS

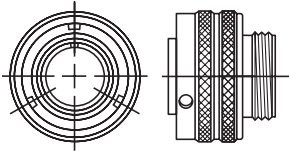

GT06A or GT06R

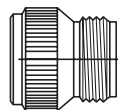

GT06AF or GT06F

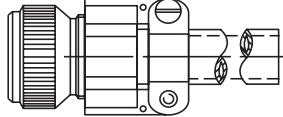

GT06CF

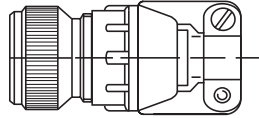

GT06G

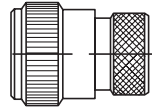

GT06LC

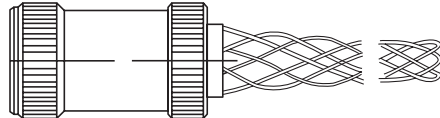

GT06LCF or GT06LCFZ

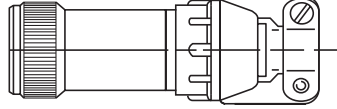

GT06PFC

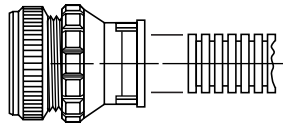

GT06RV

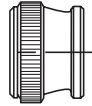

## 90 DEGREE PLUGS

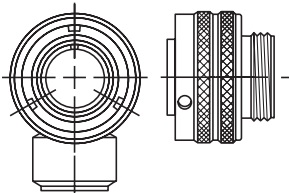

GT08A or GT08R

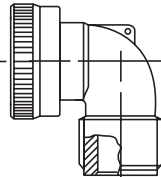

GT08AF or GT08F

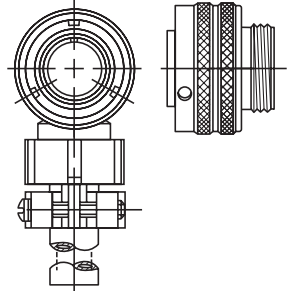
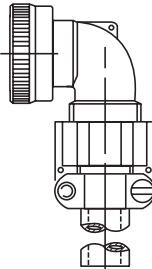

## ADDITIONAL STRAIGHT PLUGS

GT06CFGG

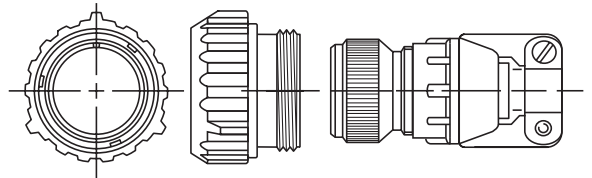

GT065SL

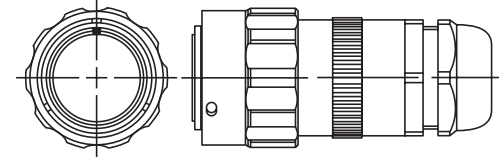

GT06PP

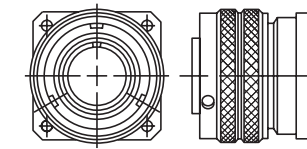

GT064PP

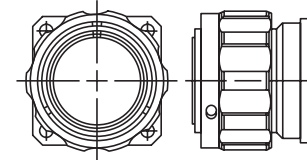

## ADDITIONAL 90 DEGREE PLUGS

GT08LT

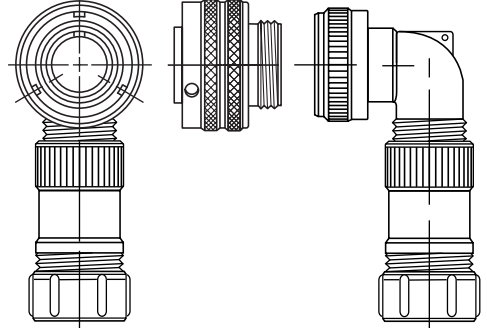

GT08PFC

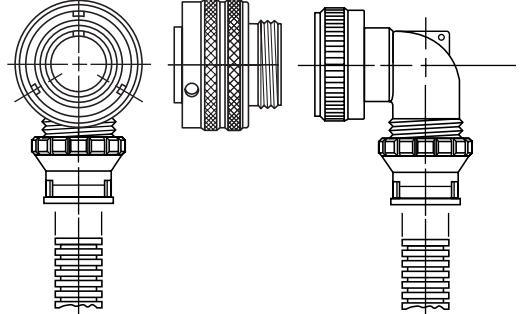

GT08CFGG

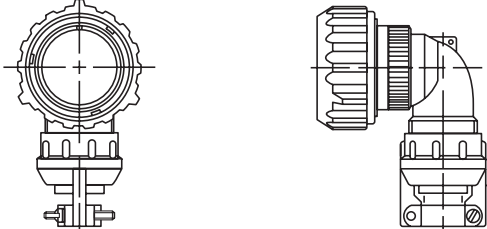



### RADSOK Layouts

The following RADSOK layouts incorporate RADSOK sockets in sizes 12, 8, 4, and 0, with standard contacts in size 16. All patterns are available in GT Series and Threaded 5015 Series. Only shell sizes 18-28 are available in P-Lok. Consult Amphenol Industrial, Fraser, MI for availability of P-Lok.

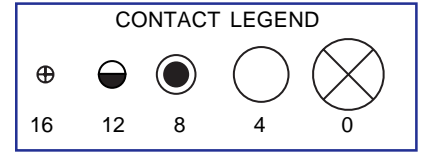

<b>1 Contact</b>	14-3	16-12	18-6	18-7	20-2	22-7
No./Size of Contacts Service Rating	1 #8 A	1 #4 A	1 #4 D	1 #8 B	1 #0 D	1 #0 E
<b>2 Contacts</b>	18-14	20-12	20-23	22-1	24-9	
No./Size of Contacts Service Rating	1 #4, 1 #16 A	1 #4, 1 #16 A	2 #8 A	2 #8 D	2 #4 A	
	28-7	32-5	<b>3 Contacts</b>	16-7	20-19	20-51
No./Size of Contacts Service Rating	2 #4 D	2 #0 D		1 #8, 2 #16 A	3 #8 A	3 #8 A
	20-59	22-2	22-6	22-21	22-80	
No./Size of Contacts Service Rating	3 #8 for #10 or 12 wire A	3 #8 D	2 #8, 1 #16 D	1 #0, 2 #16 A	3 #8 for #10 or 12 wire A	
	28-3	28-6	36-4	<b>4 Contacts</b>	18-13	
No./Size of Contacts Service Rating	3 #8 E	3 #4 D	3 #0 A = D; C = A		1 #8, 3 #12 A	
	20-20	20-24	22-4	22-22	24-22	
No./Size of Contacts Service Rating	1 #4, 3 #12 A	2 #8, 2 #16 A	2 #8, 2 #12 A	4 #8 A	4 #8 D	

### RADSOK Layouts

The following RADSOK layouts incorporate RADSOK sockets in sizes 12, 8, 4, and 0, with standard contacts in size 16. All patterns are available in GT Series and Threaded 5015 Series. Only shell sizes 18-28 are available in P-Lok. Consult Amphenol Industrial, Fraser, MI for availability of P-Lok.

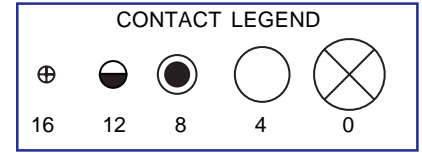

4 Contacts	32-17	36-5	36-51	40-57	
No./Size of Contacts Service Rating	4 #4 D	4 #0 A	2 #0, 2 #4 D	4 #0 E	
5 Contacts	20-14	22-12	24-12	24-51	
No./Size of Contacts Service Rating	2 #8, 3 #12 A	2 #8, 1 #16 D	2 #4, 3 #12 A	5 #8 B, E for AN #10 or 12 wire A, C, D for AN #8 wire A	
	24-53	24-79	28-5	32-1	32-2
No./Size of Contacts Service Rating	5 #8 A	5 #8 A	2 #4, 1 #12, 2 #16 D	2 #0, 3 #12 A = E; B, C, D, E = D	3 #4, 2 #16 E
	32-79	40-5	40-75		
No./Size of Contacts Service Rating	4 #4, 1 #8 D	5 #0 A	1 #12, 4 #0 E		

### RADSOK Layouts

The following RADSOK layouts incorporate RADSOK sockets in sizes 12, 8, 4, and 0, with standard contacts in size 16. All patterns are available in GT Series and Threaded 5015 Series. Only shell sizes 18-28 are available in P-Lok. Consult Amphenol Industrial, Fraser, MI for availability of P-Lok.

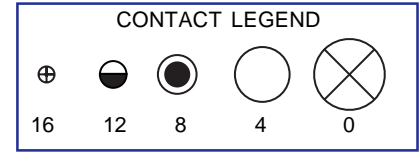

6 Contacts	20-8	20-22	28-22	28-82	36-3
No./Size of Contacts Service Rating	2 #8, 4 #16 Inst.	3 #8, 3 #16 A	3 #4, 3 #16 D	2 #8, 4 #12 D	3 #0, 3 #12 D
	36-6	7 Contacts	24-10	24-16	24-60
No./Size of Contacts Service Rating	2 #0, 4 #4 A	7 #8 A	1 #8, 3 #12, 3 #16 A, B, F, G = D; C, D, E = A	7 #8 for #10 or 12 wire A	
	24-71	24-75	28-10	32-10	
No./Size of Contacts Service Rating	2 #8, 5 #8 for #10 or 12 wire A	5 #8, 2 #8 for #16 wire A	2 #4, 2 #8, 3 #12 G = D; Bal. = A	2 #4, 2 #8, 3 #16 A, F = E; G = B; B, E = D; C, D = A	
	36-77	40-87	8 Contacts	32-15	40-AD
No./Size of Contacts Service Rating	7 #4 D	7 #4 D	2 #0, 6 #12 D	4 #8, 4 #0 A	



### RADSOK Layouts

The following RADSOK layouts incorporate RADSOK sockets in sizes 12, 8, 4, and 0, with standard contacts in size 16. All patterns are available in GT Series and Threaded 5015 Series. Only shell sizes 18-28 are available in P-Lok. Consult Amphenol Industrial, Fraser, MI for availability of P-Lok.

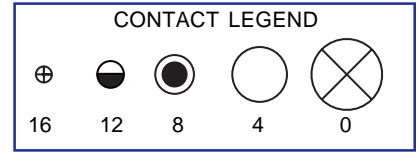

9 Contacts	22-27	24-11	28-1	28-84	28-AY
No./Size of Contacts Service Rating	1 #8, 8 #16 J = D, Bal. = A	3 #8, 6 #12 A	3 #8, 6 #12 A, J, E = D; Bal. = A	9 #8 A	4 #4, 5 #16 A

32-3	10 Contacts	24-21	11 Contacts	40-80	13 Contacts	24-58
No./Size of Contacts Service Rating	1 #0, 2 #4, 2 #12, 4 #16 D	1 #8, 9 #16 D	1 #16, 10 #4 A	3 #8, 3 #12, 7 #16 A		

40-AR	14 Contacts	32-9	36-78	40-AU
No./Size of Contacts Service Rating	3 #0, 3 #4, 7 #12 I	2 #4, 12 #16 D	12 #8, 2 #16 A	3 #4, 10 #8, 1 #16 A

16 Contacts	28-66	28-74	28-75	28-79
No./Size of Contacts Service Rating	2 #8, 14 #12 A	3 #8 for #10 wire (S, T, R) 4 #8, 9 #16 A	9 #16, 7 #8 for #10 wire A	7 #8, 9 #16 A

**RADSOK Layouts**

The following RADSOK layouts incorporate RADSOK sockets in sizes 12, 8, 4, and 0, with standard contacts in size 16. All patterns are available in GT Series and Threaded 5015 Series. Only shell sizes 18-28 are available in P-Lok. Consult Amphenol Industrial, Fraser, MI for availability of P-Lok.

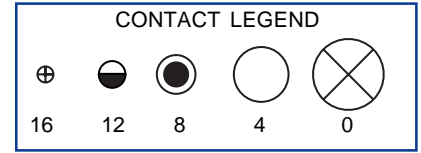

16 Contacts	32-82	36-14	21 Contacts	40-68
No./Size of Contacts Service Rating	4 #4, 12 #16 A	5 #8, 5 #12, 6 #16 D	21 #8 A	
23 Contacts	32-6	29 Contacts	40-10	29 Contacts
No./Size of Contacts Service Rating	2 #4, 3 #8, 2 #12, 16 #16 A	4 #4, 9 #8, 16 #16 A	1 #4, 2 #8, 14 #12, 14 #16 A	
34 Contacts	36-20	39 Contacts	36-54	36-55
No./Size of Contacts Service Rating	2 #8, 2 #12, 30 #16 A	8 #8, 31 #16 A	8 #8 for #6 wire, 31 #16 A	
43 Contacts	40-AT	47 Contacts	40-9	59 Contacts
No./Size of Contacts Service Rating	1 #8, 24 #12, 18 #16 A	1 #8, 22 #12, 24 #16 A	1 #8, 3 #12, 55 #16 A	

# Amphe-Power® Connectors

## HOW TO ORDER

### Amphe-Power P-Lok Part Numbering

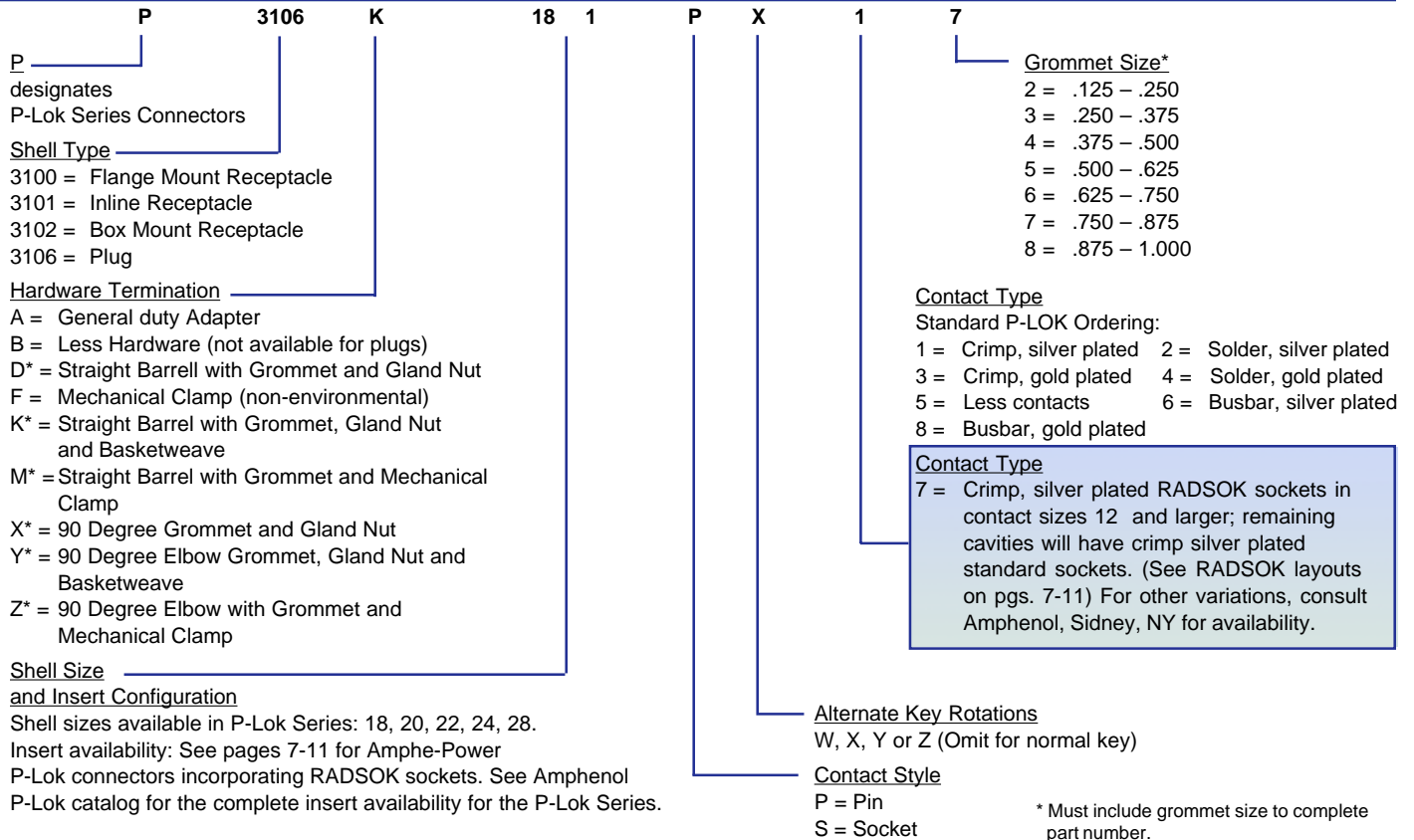

### Amphe-Power 5015 Part Numbering

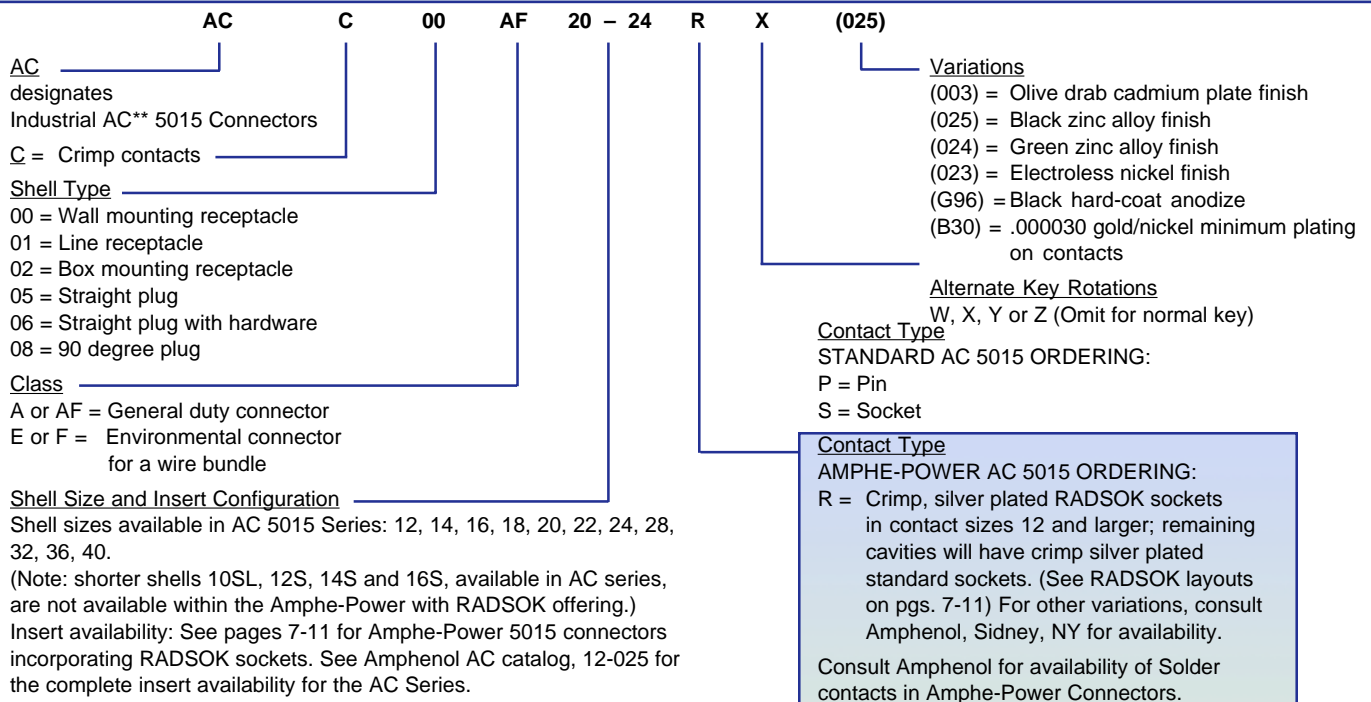

\*\* Amphe-Power 5015 Connectors are based on the AC Threaded Series from Amphenol which incorporates 5015 contact arrangements. Within the AC family a reverse bayonet style is also offered, but the bayonet style is not currently offered with RADSOK sockets. See Amphenol catalog 12-025 for more information on the AC connector family.



# Amphe-Power® Connectors

## HOW TO ORDER

### Amphe-Power GT Part Numbering

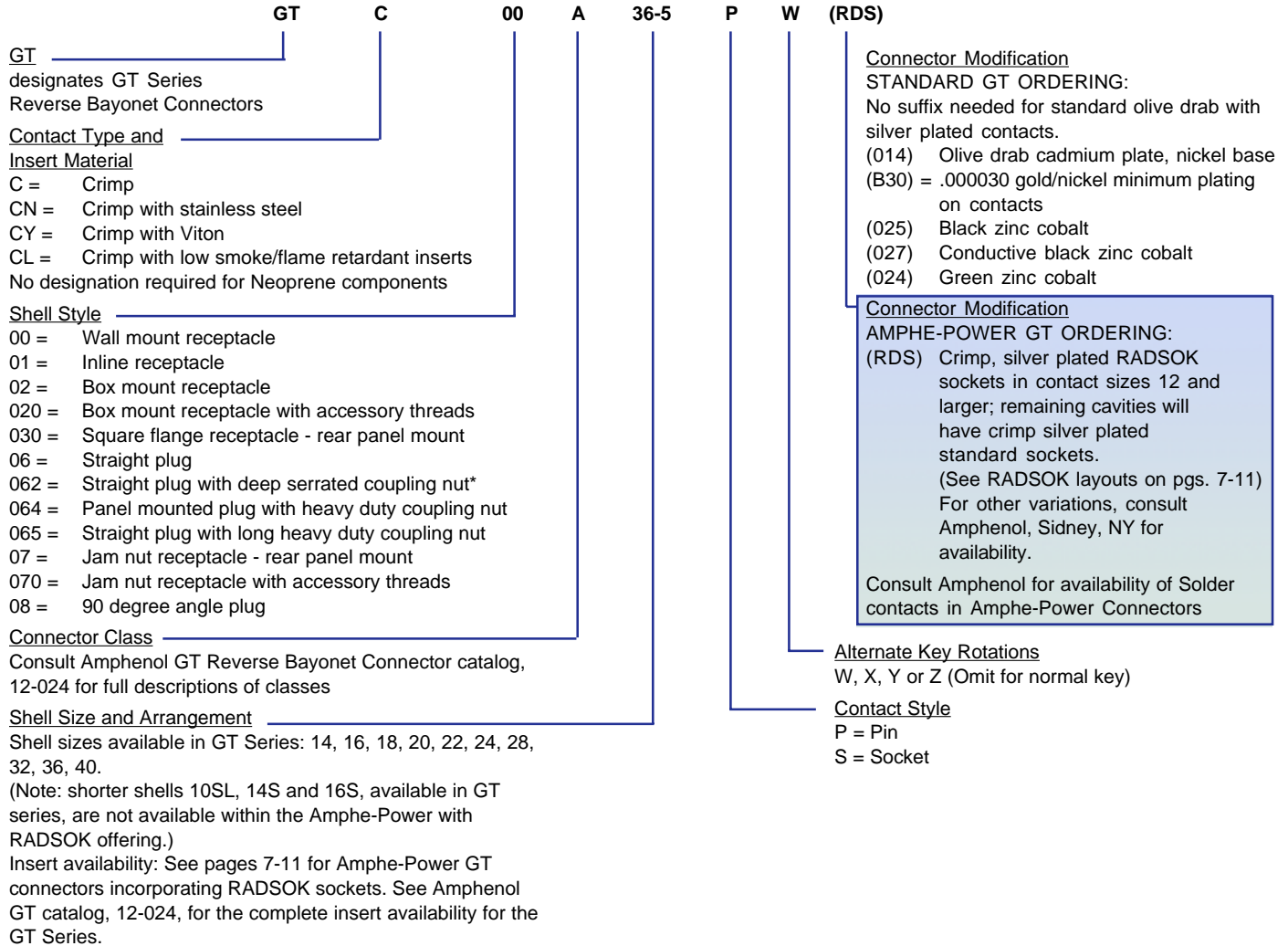

## REPLACEMENT RADSOK® CONTACTS

Consult Amphenol Industrial, Fraser, IN for more information on ordering RADSOK® contacts separately.

## ACCESSORIES FOR AMPHE-POWER CONNECTORS

Amphenol provides accessories such as connector protection caps, sealing plugs for sealing unused contact cavities, additional cable clamps, bushings, and insertion and removal tools for standard contacts. Refer to the previously referenced series catalogs for information on these accessory products:

12-024 catalog for GT Series accessories

12-025 catalog for AC 5015 accessories

P-Lok catalog for P-Lok accessories

# Amphe-Power® Composite Amphe®-GTR Connectors

## SPECIAL GT STYLE

Amphenol developed the Amphe-GTR with full worldwide approval from a major server manufacturer, for use as the environmental power connector. Featuring high-performance composite plug and receptacle shells, coupling nut, and hardware, this GT reverse bayonet connector meets all of the specifications for high power process control and server applications.

## AMPHE-GTR



- Utilizes RADSOK® high amperage socket contact technology, enabling increased current ratings to 120A on individual contacts.
- Currently available in shell size 32 with 4 conductors or 5 conductors. Current style is straight plug that houses the RADSOK® sockets and a box mount receptacle with pin contacts.
- Compression (setscrew) wire termination to the 4/6AWG or 8/10AWG conductors allows easy field replacement of pin or socket contacts, or complete plug and receptacle assemblies, without requiring specialized tooling.
- Meets same performance levels as GT Series.
- Listed to UL/CUL 1977/1682/817 Standard, control number 19VP.
- Utilizes a standard PG adapter watertight strain relief on the plug to achieve IP67 seal rating.
- Flammability rated to UL94V-0.

### AMPHE-GTR PLUG

GTR Plug in Shell Size 32 with 4 Conductors

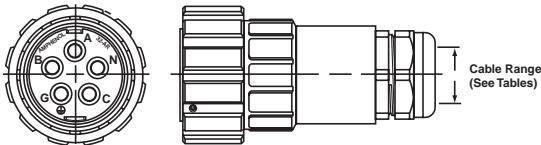

### AMPHE-GTR RECEPTACLE

GTR Receptacle in Shell Size 32 with 4 Conductors

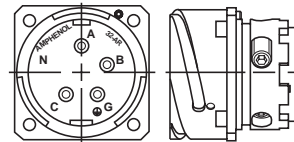

### 4 Conductors

AIO Part Number	Description	Wire Range	Rated Current	Cable Range
GT06PCM32-ARS-30(29R)	Plug	8-10 AWG	30 Amps (cont.)	.510 - .582
GT06PCM32-ARS-40(29R)	Plug	8-10 AWG	40 Amps (cont.)	.715 - .759
GT06PCM32-ARS-50(29)	Plug	4-6 AWG	50 Amps (cont.)	.809 - .905
GT06PCM32-ARS-70(29OS)	Plug	4-6 AWG	70 Amps (cont.)	1.000 - 1.185
GT06PCM32-ARS-120(36OS)	Plug	4 AWG	120 Amps (cont.)	1.27
GT030PCM32-ARP-80	Receptacle	4-6 AWG	80 Amps (cont.)	N/A
GT030PCM32-ARP-120	Receptacle	4 AWG	120 Amps (cont.)	N/A

### 5 Conductors

AIO Part Number	Description	Wire Range	Cable Range
10-610142-001	Plug	8-10 AWG	.472 - .787
10-610142-002	Plug	8-10 AWG	.708 - .984
10-610142-003	Plug	4-6 AWG	.472 - .787
10-610142-004	Plug	4-6 AWG	.708 - .984
10-610147-001	Receptacle	8-10 AWG	N/A
10-610147-002	Receptacle	4-6 AWG	N/A
10-610222-001	FBLM Receptacle	8-10 AWG	N/A
10-610222-002	FBLM Receptacle	4-6 AWG	N/A

For complete dimensional information on Amphe-GTR Series see Product Data Sheet #190. Also refer to Amphenol GT Series catalog 12-024.

# Amphe-Power® GT Connectors with TUV “Finger-Proof, 500Amps Rating

## *SPECIAL GT STYLE*

Another GT series reverse bayonet connector modification is the Power GT, incorporating three 8.0mm RADSOK® contacts mounted in a common termination to busbar or cable. This design created the first TUV “finger-proof” 500A connector in the marketplace, and provides an ultra-high current density in a compact connector layout.

### POWER GT



- Currently available in shell size 28 with three 8.0mm RADSOK® sockets on the receptacle side, in positive and negative polarizations
- Pins on the plug side can be fitted with “dead-front” tips to finger-proof the plug side as well.
- Characteristics common to the GT Standard Line, but enhanced to an ultra-high current density in a compact shell size 28 layout.
- 90° wire orientation on the plug provides low-profile mounting for tight packaging requirements.
- Plug is designed to be overmolded in 2/0 or 4/0 size wires or can be fitted with mechanical hardware.
- Plug and receptacle available in Positive (+) and Negative (-) Polarization.
- Length of cable to be determined by customer or application.

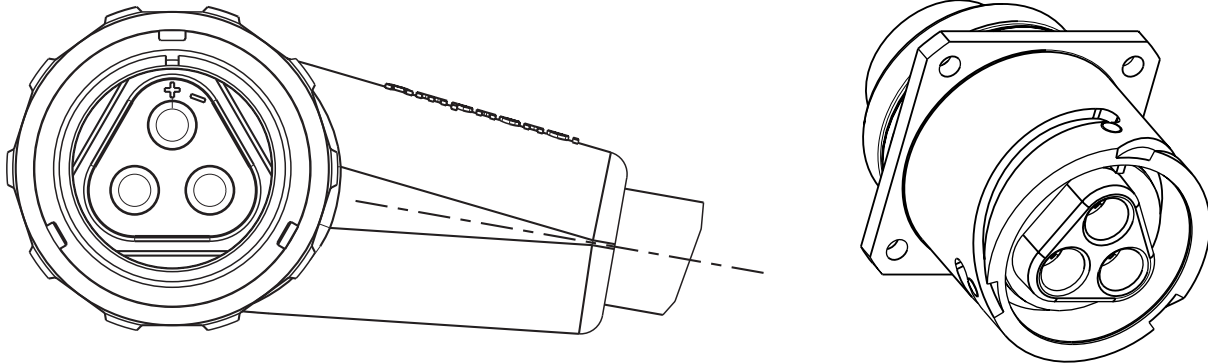

**Table of Critical Dimensions** (all dimensions are reference only)

Plug		Receptacle	
Diameter over Nut	2.020 inches	Overall length prior to overmold	2.766 inches
Distance from leading edge of plug shell to rear of shoulder of overmold	3.053 inches	Overall diameter of plug shell	1.838 inches
		Flange Dimensions	2.000 inches



# Amphe-Power® P-Lok Connectors

## 14mm RADSOK® Sockets, 500Amps Rating

### *SPECIAL P-LOK STYLE*

Amphenol developed the Power P-Lok connector with 14mm RADSOK® sockets for high amperage applications such as fuel cells, load banks or charging systems. The plug houses a single crimp pin contact and the receptacle houses a 14mm RADSOK® socket with crimp or busbar-mount termination.

### POWER P-LOK



- Currently available in shell size 28 with the single crimp contact available in 2/0 or 4/0AWG sizes.
- Rated for 500A continuous duty.
- P-Lok push-pull locking mechanism coupling and full environmental protection. Standard P-Lok connector options.
- Special optional features include a dead-front pin contact, UL recognized leakage paths, and touch-proof sockets.
- Designed to be overmolded as a custom cable assembly with EMI shield termination to the plug shell. Neoprene, Hypalon and other overmold materials are available in both straight and right-angle wire orientations.

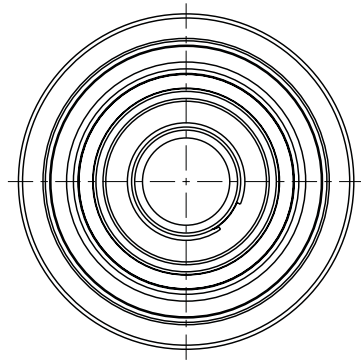

**Table of Critical Dimensions** (all dimensions are reference only)

Plug		Receptacle	
Overall length	3.743 inches	Overall length	2.426 inches
Diameter over coupling nut knurls	2.130 inches	Flange Dimensions	2.000 inches
		Dimension over receptacle shell	1.710 inches

# Amphe-Power® Last Mate - First Break P-Lok Connectors

## SPECIAL P-LOK STYLE

Another Amphe-Power product is a connector with smaller size 8AWG pins and RADSOK® sockets. The pins feature a nonconductive “Dead Front” feature for the personal safety of the user when the connector is unmated. There is also a “First mate - Last Break” pin in the pattern which connects the grounding circuit prior to the other three high amperage circuits.

## POWER P-LOK WITH FIRST MATE - LAST BREAK



- Currently available in shell size 22 with four size 8 contacts
- Four position insert pattern features longer creepage paths for high voltage applications.
- Silver plated crimp pins and sockets.
- Operating temperature range -40 Deg C to +85 Deg C.
- Non-conductive black zinc plating.
- Finger-proof pin on receptacle for personal safety.
- Self contained microswitch.

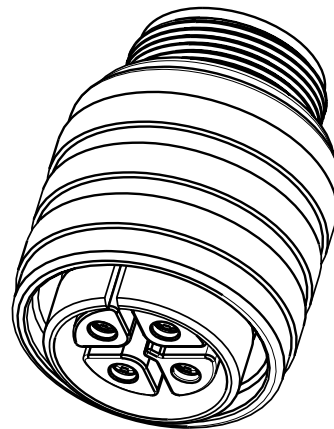
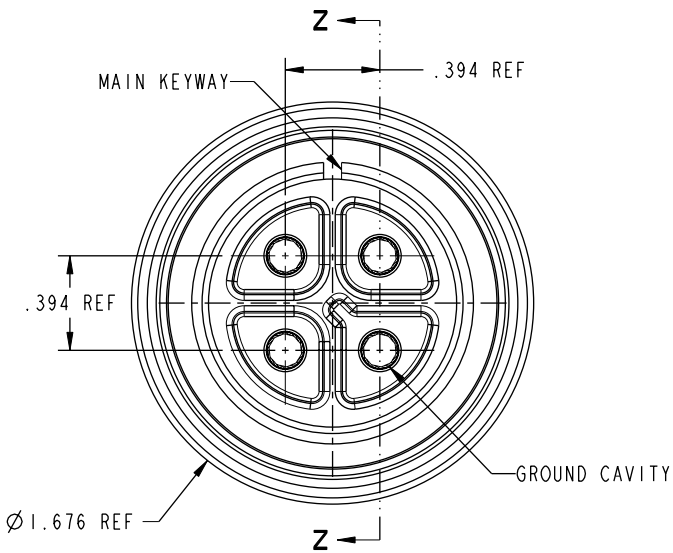

**Table of Critical Dimensions** (all dimensions are reference only)

Plug		Receptacle	
Overall length	2.193 inches	Overall length	2.053 inches
Diameter over coupling nut	1.676 inches	Flange Dimensions	1.820 inches
Accessory thread	1 3/16 - 18 UNEF - 2A Thread	Dimensions over receptacle shell	1.372 inches

# Amphe-Power® Amphe-BU™ Connectors

## SPECIAL DESIGN COMPOSITE CYLINDRICALS

Amphe-BU™ and BU single pole connectors are new Amphenol products using RADSOK® sockets. They were designed for use in induction heating welding blankets. They are UL94V-0 rated and use a rugged composite housing.

### AMPHE-BU™



- Composite shells with 1/2 turn bayonet locking.
- UL94V-0 rated.
- RoHS compliant.
- The hermaphroditic Amphe-BU™ incorporates a 14mm RADSOK® sockets and a 16AWG contact in both mating cylindrical sides.
- The BU single pole design has one 14mm hollow pin RADSOK® contact that mates to a single 16AWG contact. It is designed for use at high frequency (about 20 kHz).
- Interfacial seals, O-rings and main joint gaskets provide environmental sealing.

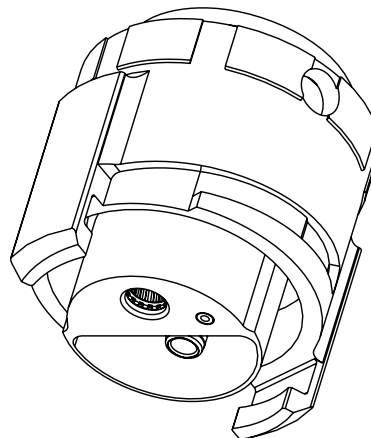
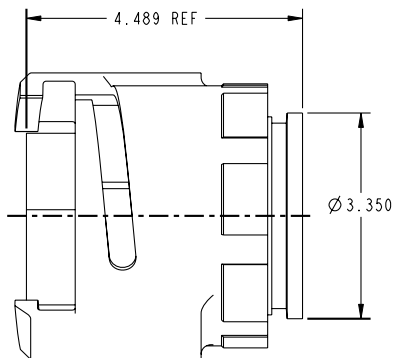

**Table of Critical Dimensions** (all dimensions are reference only)

Plug		Receptacle	
Overall length	4.489 inches	Flange Dimensions	3.100 inches
Large Diameter	4.800 inches	Dimension over rear skirt	3.225 inches
Diameter over accessory area	3.350 inches		

# Power to Board Interconnects A Wide Range of Products Utilizing RADSOK® Technology



Amphenol Industrial Operations offers a wide product offering beyond cylindrical Amphe-Power® connectors that incorporate the RADSOK® technology. These RADSOK® contact products continue to be developed to meet the ever evolving demands for high power in small packaging. Several interconnection products have been developed to provide high amperage connection to busbars, wires and circuit boards.



The advantages of RADSOK® with high amperage and low insertion forces while maintaining large conductive surface area make this technology the ideal interconnect solution for so many high power needs. With millions of RADSOK® parts in the field, this electrical connection has proven to be extremely stable, with almost no reported connection failures in Amphenol® RADSOK® designed applications.



The next few pages show several Amphenol Power Bus solutions. See how these can meet your applications, or call for engineering support to develop a solution. Whether your application is a busbar, backplane, circuit card, or wire, RADSOK® PowerBus has a solution for you.



# RADSOK® PowerBus Amphe-PD™ Connectors

RADSOK® high amperage sockets in a terminal - A compact solution for datacom applications which require small, yet powerful connectors. The Amphenol® Amphe-PD™ supports 50A to 70A continuous power and generates more processing power with less heat than a similar sized connector.

## AMPHE-PD™



- 2 pole DC power interconnect in about 1 square inch.
- Utilizes 3.6mm RADSOK® contacts. Crimp termination.
- Molded one-piece body is strong but lightweight, Lexan construction, non-environmental.
- Easy, one-handed mating/unmating and tool-less contact insertion.
- Integrated latching mechanism has tactile and audible locking.
- Proven metal clip contact retention on receptacles; TPA device on plug to insure socket locking.
- Available in busbar mount with swage pins for single or multi-layer busbars, or box receptacle with pin-retention clip.
- UL listed at 69A and CSA listed at 55A.
- Meets RoHS and UL-94V-0 guidelines.

### AMPHE-PD™ PLUG

*Amphe-PD Plug*  
10-638974-000  
3.6mm RADSOK®

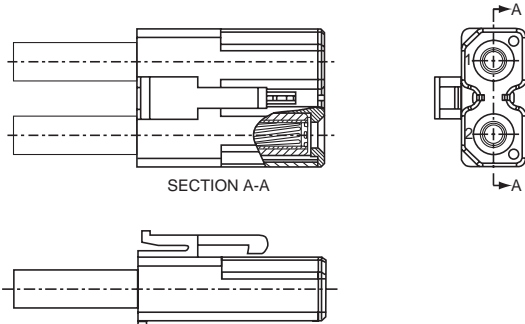

### AMPHE-PD™ RECEPTACLE

*Amphe-PD Busbar Receptacle*  
10-638975-000

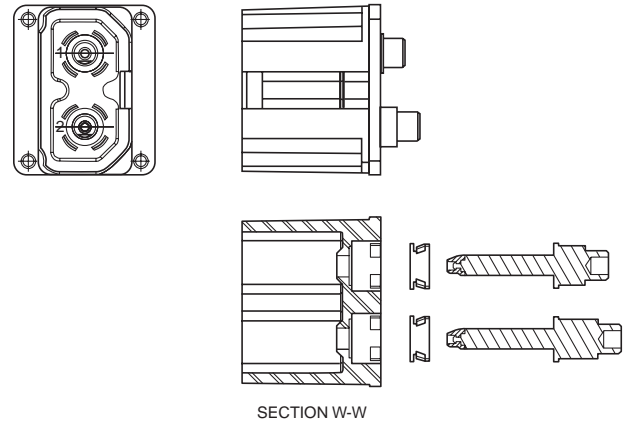

### AMPHE-PD™ RECEPTACLE

*Amphe-PD PCB Tail Receptacle*  
10-638977-000

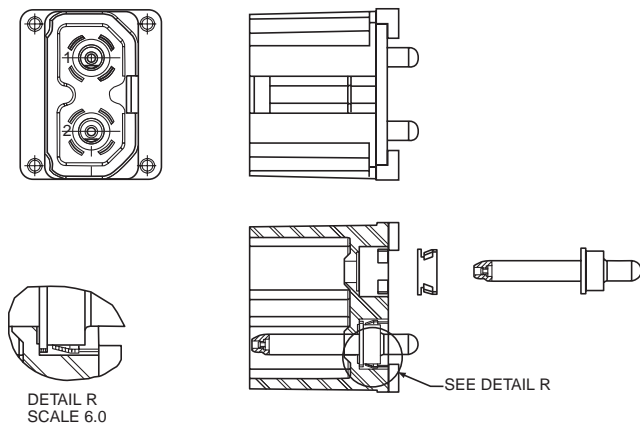

### AMPHE-PD™ RECEPTACLE

*Amphe-PD Busbar Receptacle*  
10-638975-000

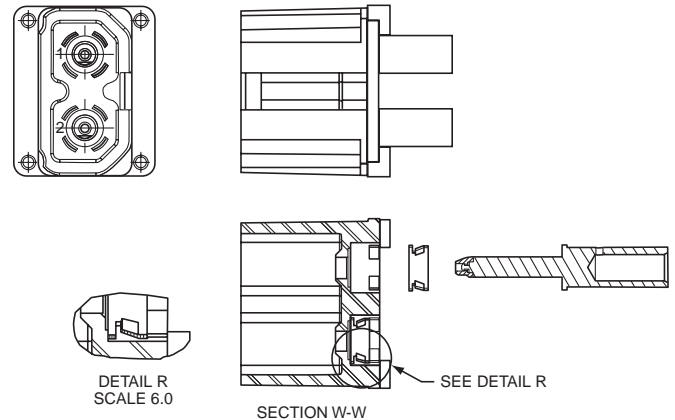

For complete dimensional information on Amphe-PD™ Series see Product Data Sheet #193.

# RADSOK® PowerBus Amphe-PD™ Bridge, RADLOK™ Connectors

The Amphe-PD Bridge and RADLOK connectors are designed for those applications where blind mating is necessary. The unique construction of the Bridge allows two pairs of circuits to be held in direct relationship to each other. The 3.6mm RADSOK socket design accommodates 50A to 70A continuous power with less heat similar connectors.

## SPECIAL AMPHE-PD™ BRIDGE CONNECTOR



- Four circuit - no latch Amphe-PD designed for blind mate applications
- Designed to hold two plugs to relationship to each other during blind mate operations
- Molded one-piece body
- Available with crimp contacts, 6AWG and 10AWG wire barrels
- Meets RoHS and UL-94V-0 guidelines
- Easy one handed mating and tool less contact insertion

## RADLOK™



- 2 pole DC power interconnect in about 1 square inch space
- Blind mate receptacle for power to the board applications
- Designed with "fastener control swage", locking RADLOK to plated through hole in board
- 2mm hex key expands and fastens RADLOK to board

## CRITERIA TO CONSIDER WHEN DESIGNING IN BOARD LEVEL PRODUCTS...

- What is the diameter of the plated-thru hole (PTH)?
- What is the thickness of the board?
- What is the amperage of the circuit?
- Where is the power coming from, above the board or below the board?
- Is the design solder or press-fit?
- What is the board footprint?
- Is the power coming from a wire or a busbar?

# RADSOK® PowerBus PowerBlok™, RADSSERT™ Connectors

Traditional methods of adding increased power to existing PCBs are often bulky and/or expensive:

- Add additional boards or increase the thickness of copper layers of the board which is expensive and traps heat within the board.
- Bring the power with wires either screwed to the board or with pluggable connections. This method can create a “rats nest” of wires and take an excessive amount of expensive board real estate.

## AMPHENOL HAS BETTER SOLUTIONS -

Amphenol Industrial has three RADSOK® solutions to add power to PCBs and preserve valuable board real estate in a system. Amphenol PowerBlok™ and Radsert™ interconnects are small and with a low profile and mount into thru-holes in the board. The Amphenol PGY™ is an interconnect that is a small stand-off component with a RADSOK® which is mounted through holes in the board.

### RADSOK® POWERBLOK™

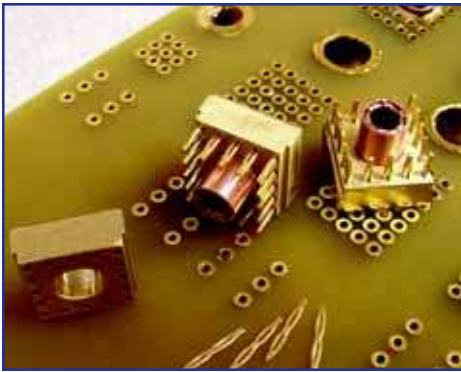

The RADSOK® PowerBlok™ provides a high current single-point connection to the PCB with the proven reliability of compliant pin signals. The PowerBlok™ is designed to bring up to 70 Amperes to the board, utilizing our custom 3.0mm RADSOK® design. The compliant pins are press-fit into the board to secure a solid connection and even flow.

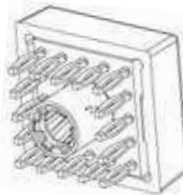

- High power to the board in a small footprint. (1/2"x1/2")
- 3.0mm RADSOK® carries up to 70AMPS.
- Backplane Power interface with compliant pins for signals.
- Touchproof cover.
- Radial design ensures many points of contact.
- Reduces failure modes, eliminates burn outs.
- No threaded fasteners.
- No special crimp tools required.
- Eliminates possible stress fractures in board.
- Faster through-put
- RoHS compliant.

### RADSOK® RADSSERT™



The RADSSERT™ design is the best option when you need the most power in a single-point connection to the Printed Circuit Board. RADSSERT™ allows the designer to bring power to the board from busbars suspended above the board and all of the board components. Pins from the busbar plug into the RADSOK®s which are installed by press fitting the RADSOK® into the Radserts™. The RADSSERTs™ are press fit into plate-thru holes in the PCB. The Radsert™ has the smallest footprint and is available in 2.4mm and 3.6mm for board sizes of .250" +/- .25".

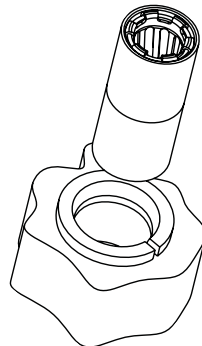

- High Power to the board in a small package.
- Hyperbolic socket design ensures many points of contact.
- Solder version or pre-loaded RADSSERTs™ are installed during board fabrication.
- 2.4mm RADSSERT™ carries up to 35AMPS.
- 3.6mm RADSSERT™ carries up to 70AMPS.
- No threaded fasteners.
- No special crimp tools required.
- Eliminates possible stress fractures in board.
- Faster through-put
- RoHS Compliant

# RADSOK® PowerBus PGY™, Busbars, RADSOK® with Flex

## RADSOK® PGY™



The RADSOK® PGY™ is our orthogonal card edge series. The 5.7mm PGY™ is our highest current board level product rated to 120 Amperes. The PGY™ is connected to the board through a solder reflow process. The busbar pin will mate horizontally with RADSOK® slightly above the board.

- Orthogonal connection between card edge and busbar/backplane.
- Compact footprint
- Legs of PGY dissipate high power evenly
- 5.7mm carries up to 120 Amps
- 3.6mm carries up to 70 Amps
- No threaded fasteners
- No special tooling required
- Faster through-put
- RoHS Compliant

## RADSOK® POWERBUS BUSBARS

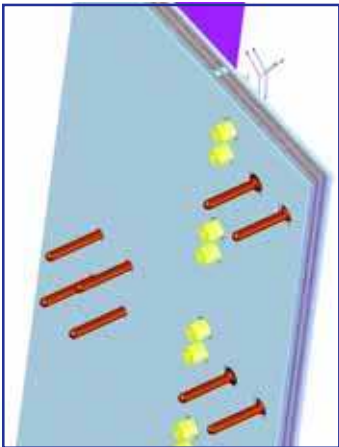

Amphenol produces RADSOK® busbars - custom designed to customer's requirements, to provide high power with increased system reliability and lower cost.

- Transfer power above, not within, the PC board.
- Plug into the board via RadSert™ or PowerBlok™ connections.
- Sheds both radiant and convective heat for efficient cooling.
- Allow for PCB attachment tolerance using SuperTwist \* RADSOK® contacts.
- May be shaped to accommodate complicated board power drops.
- Allow for fast, reliable, tool-less assembly.
- Lego Block® type assembly supports efficient busbar routing.

## RADSOK® WITH FLEX CIRCUITRY



Incorporating RADSOK® with Flexible Circuit (Flex) combines two exceptional technologies. The end results to the user are space and weight savings, increased ampacity and better performance at the end application. We can combine any of the various RADSOK® devices with Flex to provide the superior performance in the interconnect area.

### RADSOK® with Flex Assembly

- Cost effective alternative to conventional power terminations
- Eliminates routing of large gauge wires in favor of flex
- Simplifies routing of high amperage circuitry inside the box or on a panel
- Wide variety of packaging solutions available
- Option of single pin or multiple circuit solutions



# SurLok™ Compression Lugs with Plastic Housings Utilizing RADSOK® Technology

RADSOK® high amperage sockets in a non-environmental low mating force compression lug - A highly reliable alternative to common compression lugs. The SurLok™ offers high current rating of 70A to 300A in a small package. For busbars, PC boards and cable assemblies; any power distribution application that uses high current, frequently plugged and unplugged cables or a “plug and play” setup are ideal for the Amphenol® SurLok™.

## SURLOK™



- Designed to meet or exceed the electrical performance of bolt-on lugs; provides higher ampacity, vibration resistance and high reliability; takes up less space than conventional lugs
- Head of the pin locks into place once mated to the RADSOK® connector.
- The plastic housing snaps over the connector and acts as a protective cover and are color coded for positive and negative circuits.
- Secure connection ensures voltage and amperage levels will be maintained.
- Easy field install - crimp with standard color-coded dies (U-die and 4-indenter) No torque wrenches required.
- RoHS compliant
- UL listed under file UL1977
- Engagement force: ~2 lbs. – 5 lbs. mating insertion and ~10 lbs. – 15 lbs. locking
- Separation force: ~10 lbs. – 15 lbs.
- Contact surfaces are silver plated on the pin and socket. Wire crimp barrel is matte tin per industry standards.

Wire Size AWG	mm <sup>2</sup>	RADSOK® Size	Current Rating	SurLok™ Assembly <sup>(1)</sup> Part Number	Lug Only <sup>(2)</sup> Part Number	Conductor Max. Dia.		Crimp Code
						Inch	mm	
8	10	3.6mm	70 Amps	PSL-368K	PSL-368	0.17 in.	4.32	Red 21
6	16	5.7mm	100 Amps	PSL-576K	PSL-576	0.21 in.	5.33	Blue 24
4	25	5.7mm	125 Amps	PSL-574K	PSL-574	0.27 in.	6.85	Gray 29
2	35	8.0mm	175 Amps	PSL-802K	PSL-802	0.30 in.	8.89	Brown 33
1	50	8.0mm	200 Amps	PSL-801K	PSL-801	0.35 in.	9.65	Green 37
1/0	50	10.3mm	250 Amps	PSL-10310K	PSL-10310	0.38 in.	11.18	Pink 42
2/0	70	10.3mm	300 Amps	PSL-10320K	PSL-10320	0.44 in.	12.7	Black 45

Pin Dia.	Max. Current	Part Number	Thread (male)
3.6mm	70 Amps	PSLP-36	M3x0.5
5.7mm	125 Amps	PSLP-57	M5x0.8
8.0mm	200 Amps	PSLP-80	M8x1.25
10.3mm	300 Amps	PSLP-103	M10x1.5

Notes: (1) Surlok™ Assembly contains the wire crimp lug, plus a two-piece dielectric clamshell housing. Housing is available in black color as standard. Consult Amphenol Industrial for alternate color options.  
 (2) Lug only specifies the wire crimp RADSOK® SurLok™ lug, less the plastic housings.

# RADSOK® PowerBus Amphe-Base™, Amphe-Com™, HiLok™ Connectors

## AMPHE-BASE™



Molded circuit connectors with 2-3 positions for backplane, PC board or busbar applications. Amphe-Base interconnects provide 120 amps per pin of power.

- Molded, one-piece Lexan® construction provides a strong, durable, lightweight, non-environmental connector for base station power.
- Utilizes 2 or 3 position RADSOK® 6mm sockets.
- Crimp contacts available for 4AWG to 12AWG wire size.
- Allows one-handed mating and unmating, tool-less contact insertion.
- Low insertion/extraction force. Ultra-high service reliability.
- Off-center spacing of the socket positions provides a failsafe orientation of the connector, insuring the correct circuits are properly mated.
- Circuit identification symbols (+, -, and Ground) are molded in for quick and easy identification.

## AMPHE-COM™



Another custom molded interconnect is the Amphe-Com™ with RADSOK® in a single position. Designed for high power applications and infocom power distribution, this interconnect provides 200 amps of power.

- Single position with 8mm RADSOK® contacts.
- Simple push-on to mate, pull off to unmate.
- Crimp termination or PCB/busbar.
- Has molded socket shell and is available with a plastic cap
- Available with or without plastic molded identification cap

## HILOK®



Invented in response to customer demand for a tool-less but semi-permanent high amperage connector, the HiLok™ is often used as a replacement to the traditional threaded post and ring terminal.

- Available in standard RADSOK® sizes of 3.6mm (70A), 5.7mm (120A) and 8.0mm (200A).
- Sockets are available with a wide range of wire crimp barrels from 1/0AWG to 12AWG.
- Crimp termination pin contacts with wire crimp barrels or PCB/busbar swage mount features..
- Custom termination methods are available for specific applications.
- The HiLok™ function is characterized by low connection force requirements of less than 15 pounds, and high removal force requirements of greater than 50 pounds.
- Removal tool is available for easy disconnection of the mated contacts.

# RADSOK® PowerBus Amphe-Y™, Amphe-Armor™, TruLok™ Connectors

## AMPHE-Y™



The Amphe-Y features RADSOK® sockets and is a high amperage/high voltage assembly designed for the rail industry. This product is used in mass transit traction motors and is an ideal replacement for high-current bolted connections that absorb high labor costs and add excessive time for maintenance and repair procedures.

- Allows for easy access to traction motor wiring.
- 1000A/1000V power rated.
- Triangular-shaped junction box has three connection areas, each with a RADSOK® 18.0mm size contact. These supply continuous current through 646MCM cables to locomotive conductors.
- Cover is removed with bolts to allow the pins to be unmated.
- Designed to be fully seated and ruggedized for harsh rail environments.
- Has IP67 rated moisture sealing.

## Amphe-Armor™



The Amphe-Armor™ series was designed to provide superior durability and water tight construction to withstand any harsh environment. This rugged connector stems from the over molded PT Bayonet connector and also comes in a power version; available with Amphe-Power® GT inserts for the most powerful and rugged connector in the market.

- Over Molded for Protection and Sealing
- Field Installable, Field Repairable
- Molded housing made of high impact glass-filled thermoplastic
- IP 67 Rated
- Internal Stress Relief
- Heavy Duty Coupling Nut

## TRU-LOC®

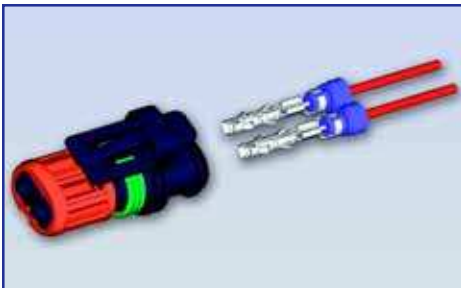

Amphenol Industrial offers the Tru-Loc®, a 2-pin connector with specially configured stamped and formed 1.5mm RADSOK® socket contacts. This product was first developed for the heavy equipment marketplace to control the timing of a fuel injector. Designed to be used in tight spacing situations and to perform in demanding environments, such as under valve covers on diesel engines and in various under-the-hood interconnect applications.

- Contacts plug into the Tru-Loc® molded thermoplastic plug body which has a latch, Viton main joint seal and silicone rubber wire seals.
- Push-pull coupling with secondary lock.
- Crimp 1.5mm RADSOK® sockets are rated at 7.5A.
- IP67 rated. Tested per IEC 512 and IEC 68-2.
- Durability: 20 mating cycles.

### AIO Part Number

3 piece plug (plug body, locking collar and main joint seal)	10-838137-000
Viton wire seal	10-838137-00D
RADSOK socket contact	10-838138-000

RADSOK® sockets for Tru-Loc® are available on reels of 4,000 pieces.

# More Amphenol® RADSOK® PowerBus Products

Amphenol continues to grow and meet the demands for new applications in high power technology. RADSOK® technology has proven to be the reliable product solution for more and more interconnect requirements. We are broadening into new markets and meeting customer needs for special applications - board level products, cylindrical products and even hybrid contact arrangements of RADSOK® with other types of contacts combined in one connector package.

## RADSOK® IN LRM CONNECTORS

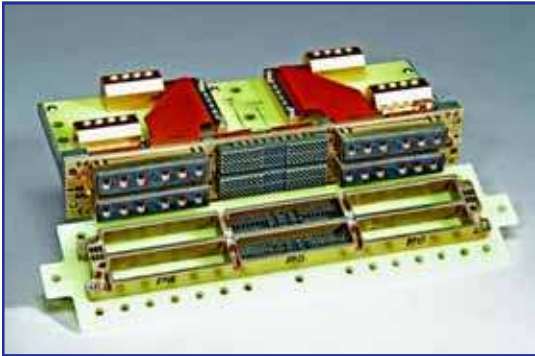

Line Replaceable Module (LRM) board level interconnects enhanced with RADSOK® contacts.

- The RADSOK® advantages of high amperage capability with minimal voltage loss and low insertion forces was advantageous to be used in LRM interconnects for high speed data transfer.
- One bay, two bay or three bay configurations with high densities of contacts.
- LRMs can have combinations of contact types: Brush contacts, high speed shielded contacts, and combinations of power contacts and fiber optics.
- Photo left shows a special 6 bay LRM with RADSOK® contacts, standard brush contacts and flex circuitry termination to module circuit card assemblies.

## RADSOK® IN AMPHENOL®/ MATRIX® MIL-DTL-5015, SERIES II

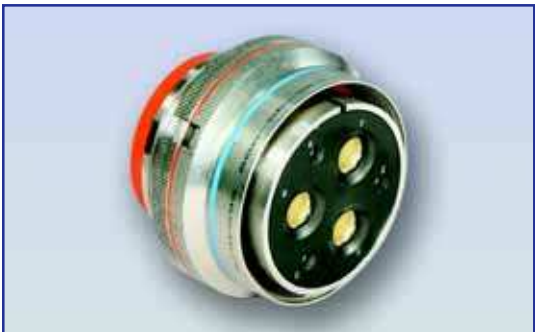

High Power RADSOK® is now developed into applications for engine connectors for Commercial Air.

- A special design of the Matrix® MIL-DTL-5015, Series II connectors has added high amperage with the RADSOK® contacts in the plug instead of standard rear release crimp contacts.
- The Matrix 5015 is a mil-spec qualified, environmental connector series with improved sealing and it is widely used in the Commercial Air marketplace.

## RADSOK® AND BRUSH CONTACT COMBINED



The B<sup>3</sup> brush (bristle brush bunch) contact is comprised of multiple strands of high tensile wire that intermesh to create an electrical connection.

- Redundant current paths: 14-70 gas tight points of contact per mated bunch.
- Very smooth low friction interface.
- Low mating forces: 1.5 oz. typical per contact, 70-90% lower than conventional contacts.
- Long contact life: 100,000 cycles of mating and unmating without performance degradation.
- Documented intermittency free performance: No 10 nano-second discontinuities during 50,000,000.
- Impervious to fretting.
- Contact interface meets M55302/166 thru /171

For more information about any of the products seen in this catalog consult Amphenol Industrial, Fraser, MI.

Call us: 1-586-294-7400 or Email us: [radsok@amphenol-aio.com](mailto:radsok@amphenol-aio.com)