



**Applied
Motion
Products**

404 Westridge Dr. • Watsonville, CA 95076
(831) 761-6555 • (800) 525-1609 • FAX (831) 761-6544
www.applied-motion.com



The 3540 Series drive (PDO 3540) and drive/indexer systems (Si3540) are designed around a precise, high power step drive suitable for use with NEMA 14 through NEMA 34 motors. Reliable and rugged, the 3540 series is capable of microstepping resolutions up to 50,800 steps per revolution at speeds to 50 RPS while providing smooth torque, low vibration and precise positioning.

One of the Si3540's outstanding features is Applied Motion's "Simple Indexer Technology™" Windows™ graphical user interface for stand alone applications. No

programming to learn, no software engineer to consult, no code to write. All you do is POINT-CLICK-MOVE. The Si™ interface does the programming, you need only input the move parameters. If your single axis application requires the Si3540 to be operated by a host computer simply connect it to your PC or PLC and invoke our SiNet™ Command Language. For multi-axis applications up to 8 Si™ drives can connect to one PC serial port using our SiNet Hub-8. All series 3540 products are CE & TUV compliant.

3540 SERIES DRIVES/INDEXERS

Technical Specifications

POWER AMPLIFIER (MOTOR DRIVE) SECTION 3540 SERIES:

AMPLIFIER TYPE	MOSFET, dual H-Bridge.
CURRENT CONTROL	3 state, pulse width modulated, switching at 20KHz.
OUTPUT CURRENT	Si3540: 0.2–3.5 amps, software selectable, PDO 3540: 0.4–3.5 amps, dip switch selectable.
DC BUS VOLTAGE	40 VDC.
AC INPUT VOLTAGE	110 or 220 VAC (switch selectable) 50/60 Hz.
MAXIMUM OUTPUT POWER	122 watts.
IDLE CURRENT REDUCTION	Si3540: 0%, 25%, 50%, or 100% software selectable. PDO 3540: 0% or 50% dip switch selectable.
MOTOR RESOLUTION	Si3540: 13 resolutions. Steps per revolution with 1.8° motor: 2000, 5000, 10000, 12800, 18000, 20000, 21600, 25000, 25400, 25600, 36000, 50000, 50800, software selectable. PDO 3540: 16 resolutions. All the resolutions of the Si3540, plus 200, 400, and 1000 steps per revolution, dip switch selectable.
STATUS LED'S	AC power (red).

CONTROLLER (INDEXER) SECTION Si3540:

SERIAL COMMUNICATION	RS-232 programming port.
INPUTS	8 user programmable inputs. Can be used for triggering, sensing, homing, branching, jogging or limits. 5-24 VDC optically isolated.
OUTPUTS	3 general purpose, optically isolated outputs for interfacing to other equipment. Open collector and emitter. 30 V, 100 mA max.
PARAMETER RANGES	Distance: 1 to 16,000,000 steps. Speed: .025 to 50 revolutions per second (in any microstep resolution). Acceleration: 1 to 3,000 rev/sec/sec. Deceleration: 1 to 3,000 rev/sec/sec (set independently from acceleration). Time Delays: 0.01 to 300 seconds. Output Pulse Widths: 2 to 500 milliseconds. Iterations per repeat loop: 1 to 65,535.
OPTIONAL OPERATOR INTERFACE (MMI)	NEMA 4/12 rated (splash proof & dust proof). 4 x 20 characters liquid crystal display (LCD). 20 key membrane keypad. Overall size: 4.9 x 4.9 x 1.42 inches.

CONTROLLER (OSCILLATOR/SEQUENCER) SECTION PDO 3540

DIGITAL OSCILLATOR	Precise speed control with automatic ramps between speeds. The accel/decel rates are set by an on-board potentiometer, and are adjustable from 1 to 250 rev/sec/sec.
SPEED SETTINGS AND RANGE	On-board: High Speed and Low Speed potentiometers. High speed: 0 - 25 rps. Low speed 0–5 rps. External: 0–5V analog voltage, external potentiometer, or analog joystick. 0–25 rps, trimmed by High Speed potentiometer.
MODES OF OPERATION	4 modes are dip switch selected: Self Test: built-in troubleshooting diagnostic. Pulse and Direction: works with pulse and direction controllers. Oscillator: Speed is controlled by on-board potentiometers and/or an external 0–5V analog voltage. The Step input starts and stops the motor, Speed selects the speed range. Joystick: Speed and direction are determined from an external analog voltage. Inputs Step and Direction can be used as limit switches. Speed input selects speed range. On-board potentiometers adjust the speed ranges.
STEP AND DIRECTION INPUTS	Optically isolated. 5–12V (24V requires 1K ohm dropping resistors). Step requires a 0.25 microsecond minimum pulse width and the maximum step rate is 2 MHz. The direction signal setup time is 1 microsecond minimum.

SYSTEM SPECIFICATIONS:

OVERALL SIZE	2.25 x 7.8 x 5.40 inches. See mechanical outlines page 4.
CHASSIS MATERIAL	Aluminum, black anodized with integral heat sink.
CASE	Steel with black paint and white epoxy silk screen. Includes switch covers.
WEIGHT	4 lbs.
AMBIENT TEMPERATURE	0° to 50°C (32° to 122°F).
HUMIDITY	Maximum of 90% non-condensing.
CONNECTORS	Screw terminal connectors for input power and motor, and I/O signals.
MOTORS	Can drive 4, 6 or 8 lead motors, NEMA sizes 14–34.
AGENCY APPROVAL	CE & TUV.

Technical Drawings

PDO 3540

CONNECTOR DIAGRAM

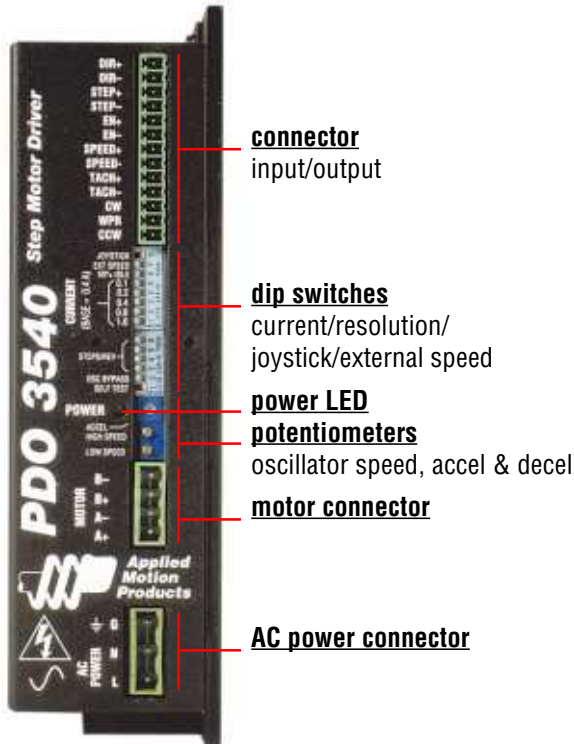

BLOCK DIAGRAM

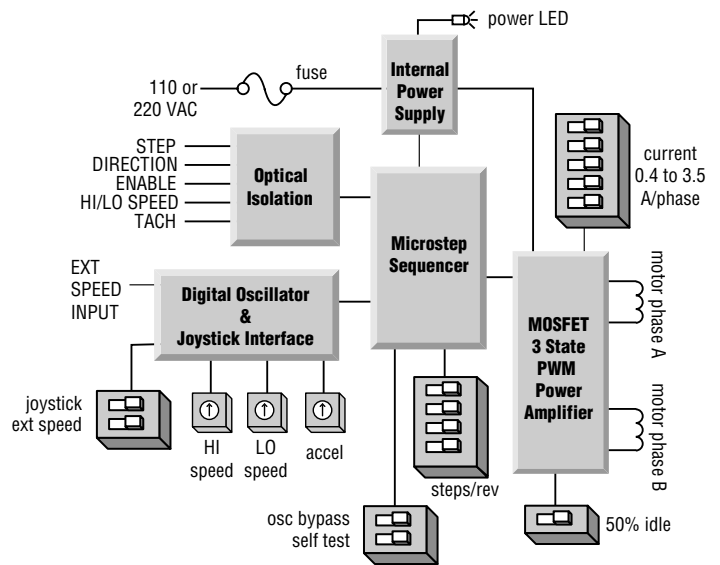

Si3540

CONNECTOR DIAGRAM

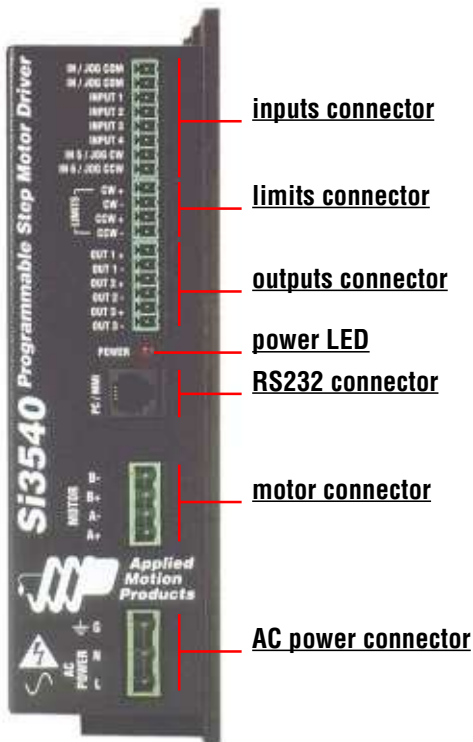

BLOCK DIAGRAM

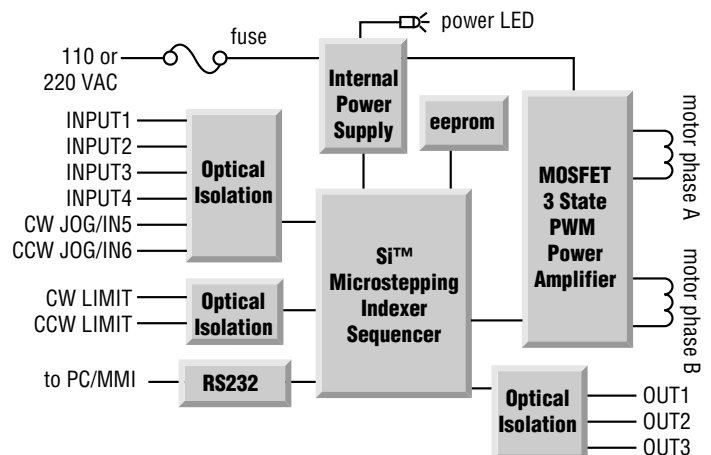

Mechanical Outlines

PDO 3540 Outline

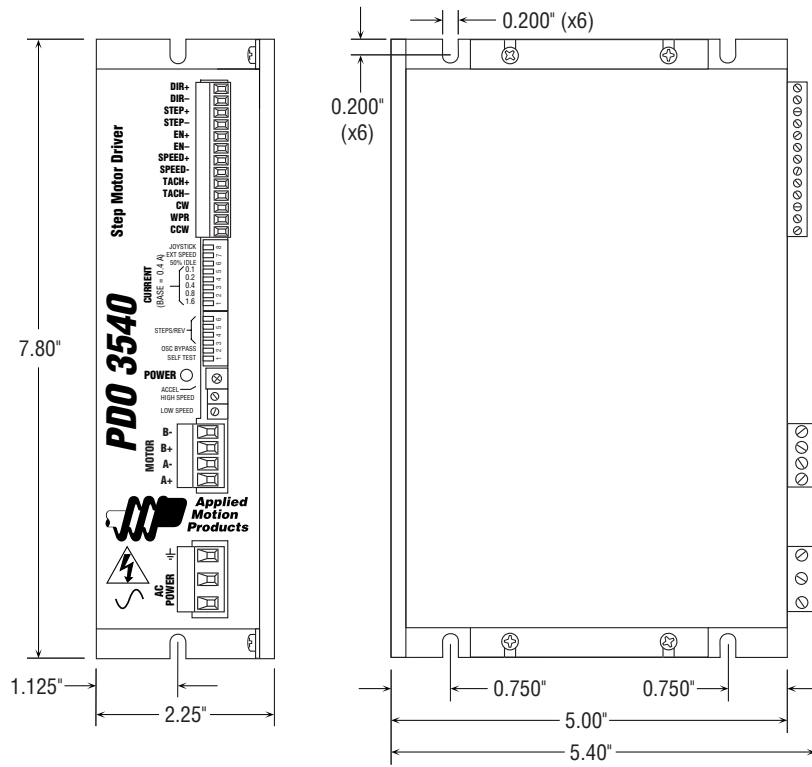

Si3540 Outline

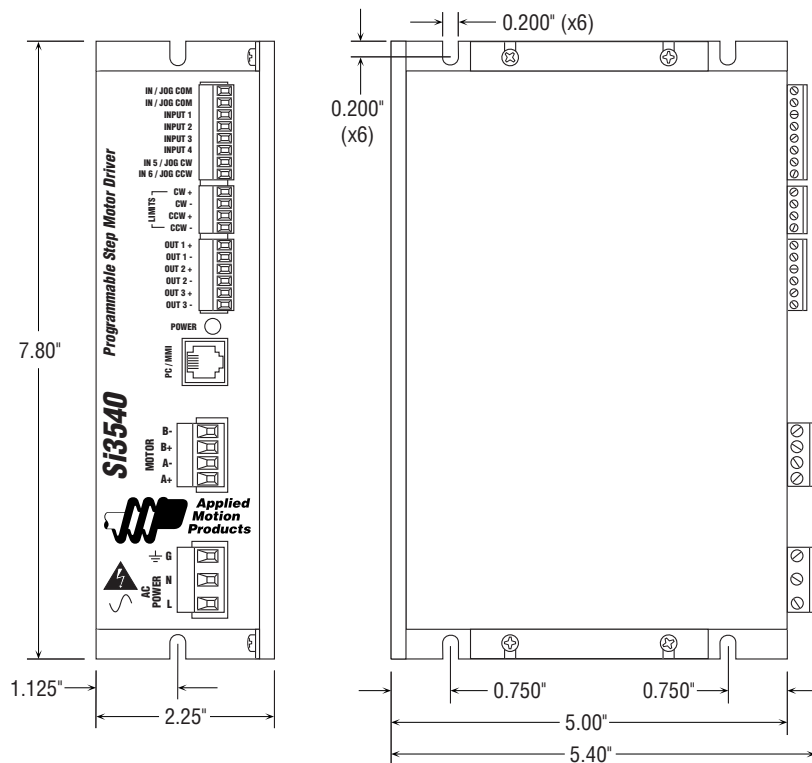

Si Software Specifications

INDEXER PROGRAMMING:

Programmable by RS-232 connection to IBM compatible PC running Windows 3.1, Windows 95, Windows 98 or Windows NT. Programming software and cable included. Programming is very easy to learn and requires no previous programming experience.

Programs can be up to 100 lines long. Instructions are powerful, so 100 lines can provide the user with a sophisticated program. For example, in one program line the motor can be moved until a sensor changes state, then fed a precise distance to a stop, delayed and

ing input/output, branches, loops and motion commands. These instructions can be combined to make a nearly infinite variety of programs, meeting the demands of a wide range of applications.

As you compose your program, you can test it by downloading to a drive and executing. A sophisticated control panel allows you to observe the status input and output terminals in real time, highlights the instruction that's executing, and allows you to pause and single step the program.

You can even emulate the optional Man Machine Interface on-screen. This allows you to try out the MMI before buying one, and eliminates the need to swap cables between the PC and MMI while you're testing your program.

You can also write programs without a drive connected to your PC and save them to your hard disk.

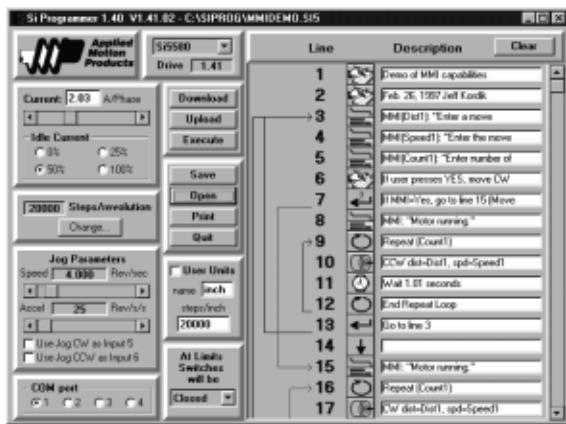

Main Programming Screen

returned to the starting point. Distances, delays, feed and return speeds, acceleration and deceleration parameters are all included in the single program line. The same move can take 10 program lines or more on other indexers.

There are a total of 20 different instructions, includ-

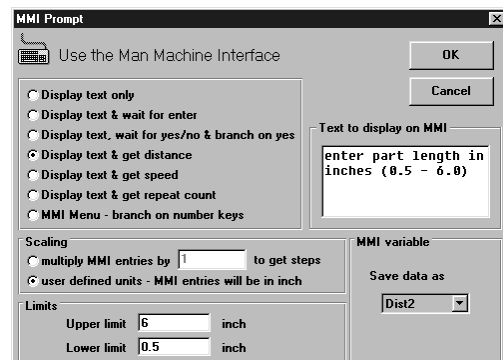

Typical Dialog Box
(for setting *Feed to Length* instruction)



Program Menu

Once programmed, the cable can be removed and the indexer-drive will run stand alone. Programs and parameters are stored internally in nonvolatile memory. Upon power up, the drive automatically senses the connection to the Windows programming software. If no connection is detected, the program is automatically executed starting on line 1.

All Si products support an optional NEMA 4X operator interface (MMI) that allows the operator to enter variables such as speeds, distances and repeat counts. The MMI attaches to the RS-232 programming port, leaving all inputs and outputs free.

A CNC hand wheel is also available, allowing a machine operator to precise position a motor and load.

Motor Dimension Drawings

SIZE 14 FRAME

MODEL*
5014-842

L (motor length)
1.57

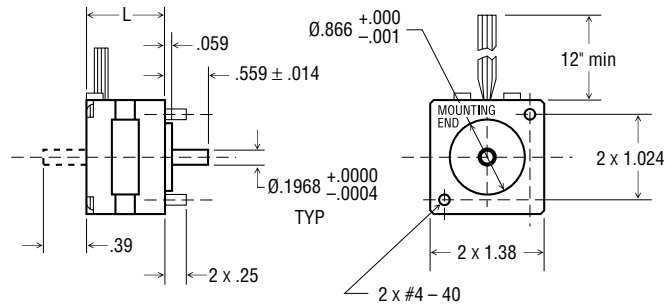

SIZE 17 FRAME HIGH TORQUE MOTOR

MODEL*
HT17-068
HT17-071
HT17-075

L (motor length)
1.30
1.54
1.85

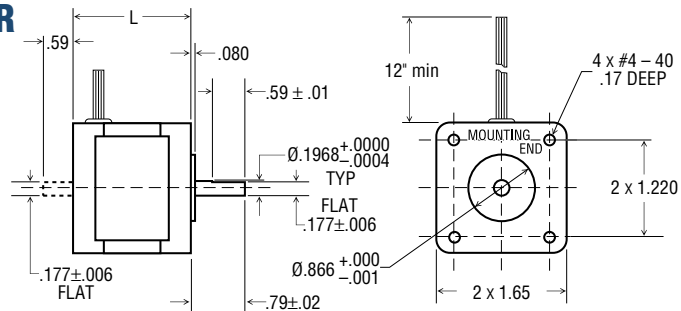

SIZE 23 FRAME

MODEL*
5023-122
5023-123
5023-124

L (motor length)
2.0
3.0
4.0

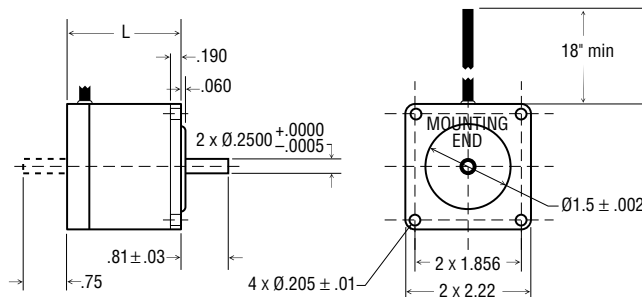

SIZE 23 FRAME HIGH TORQUE MOTOR

MODEL*
HT23-394
HT23-397
HT23-400

L (motor length)
1.54
2.13
2.99

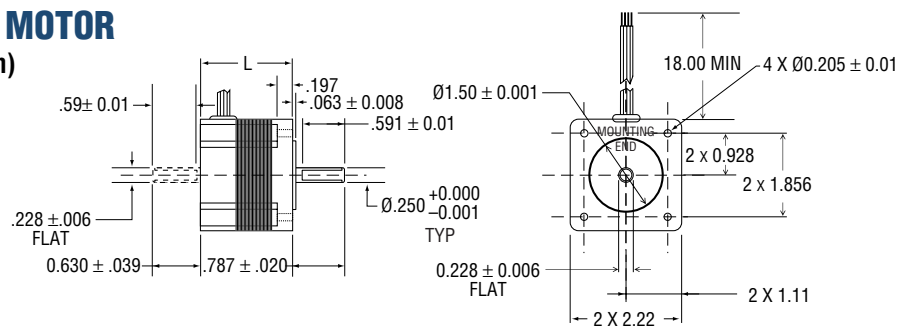

SIZE 34 FRAME

MODEL*
5034-348
4034-334

L (motor length)
2.5
5.1

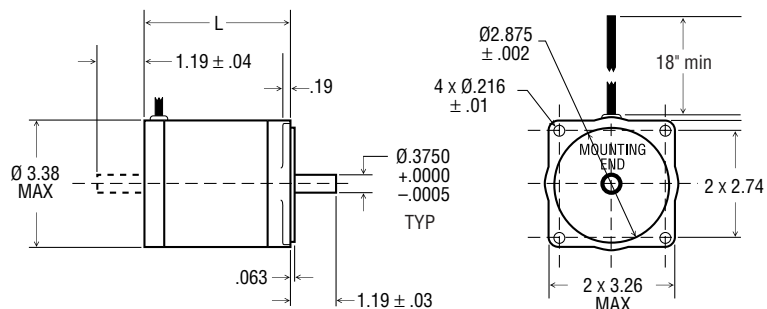

* Part numbers listed are for single shaft. To order double shaft add "D" to the end.

Torque Curves

Motor may experience resonance at speeds between 1 to 5 RPS.

5014-842 MOTOR

Step Resolution: 1/10th Step
Motor Current: 1.4 amp, End to End Connected

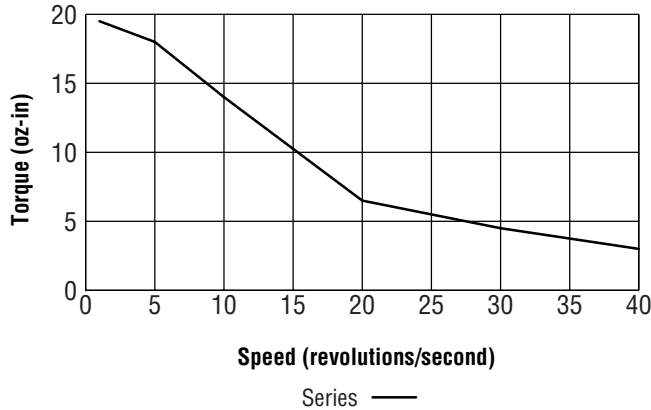

HT17-068 HIGH TORQUE MOTOR

Step Resolution: Full & 1/10th Step
Motor Current: 1.4 amp, Parallel Connected

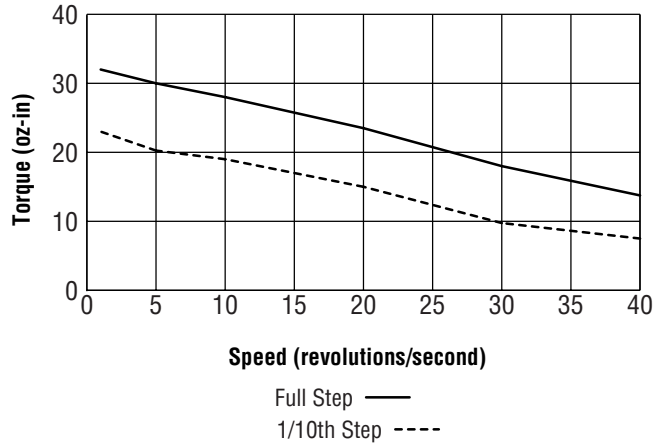

HT17-071 HIGH TORQUE MOTOR

Step Resolution: Full & 1/10th Step
Motor Current: 1.7 amp, Parallel Connected

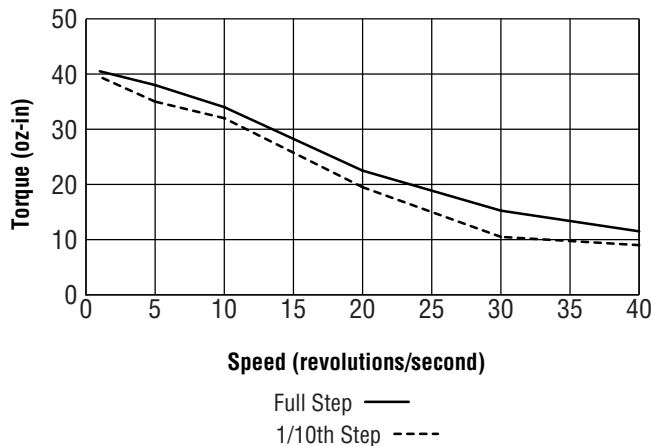

HT17-075 HIGH TORQUE MOTOR

Step Resolution: Full & 1/10th Step
Motor Current: 1.7 amp, Parallel Connected

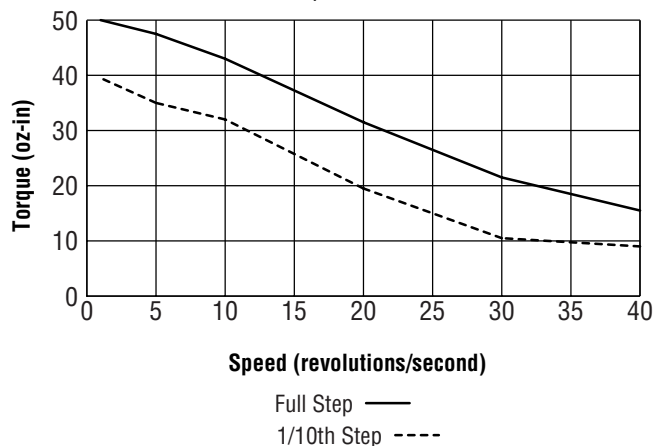

5023-122 MOTOR

Step Resolution: Full & 1/10th Step
Motor Current: 2.0 amp, Parallel Connected

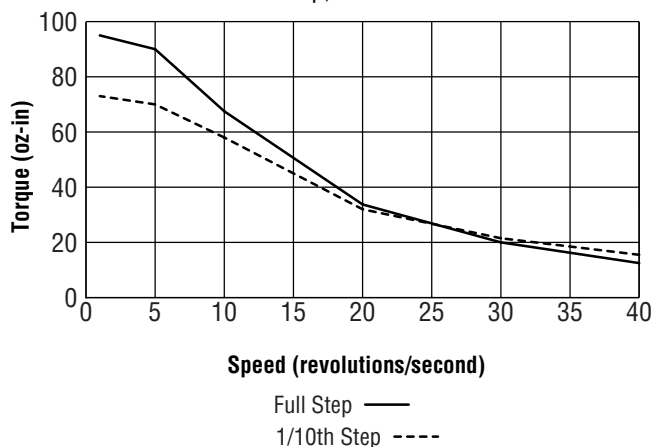

5023-123 MOTOR

Step Resolution: Full & 1/10th Step
Motor Current: 2.5 amp, Parallel Connected

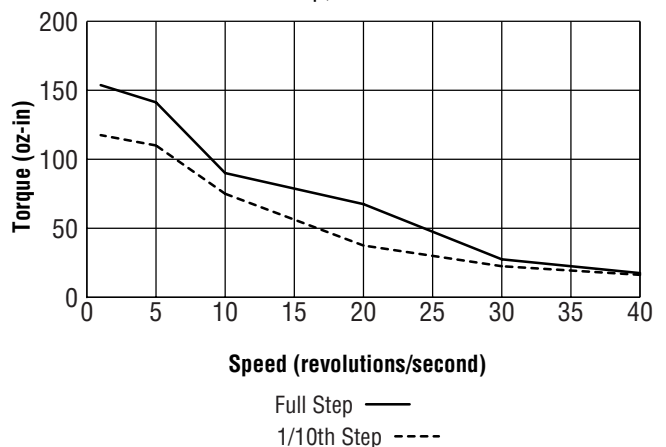

Torque Curves

Motor may experience resonance at speeds between 1 to 5 RPS.

5023-124 MOTOR

Step Resolution: Full & 1/10th Step
Motor Current: 3.5 amp, Parallel Connected

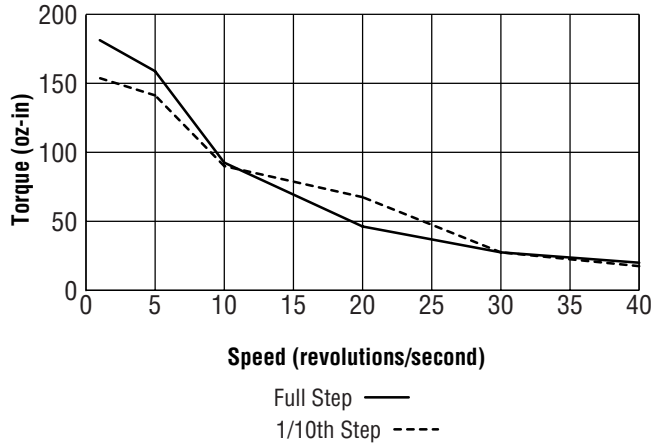

HT23-394 HIGH TORQUE MOTOR

Step Resolution: Full & 1/10th Step
Motor Current: 2.8 amp, Parallel Connected

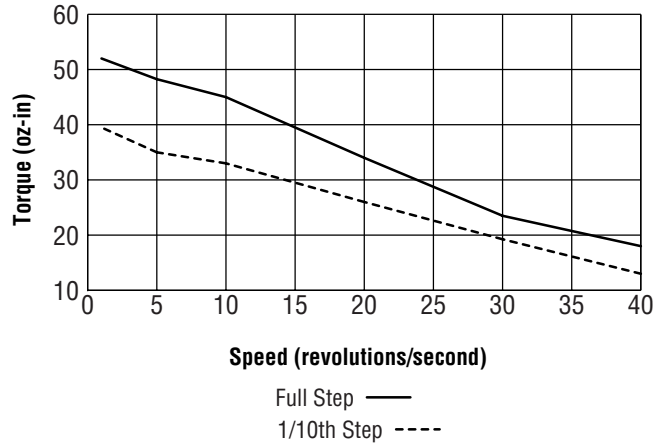

HT23-397 HIGH TORQUE MOTOR

Step Resolution: Full & 1/10th Step
Motor Current: 2.8 amp, Parallel Connected

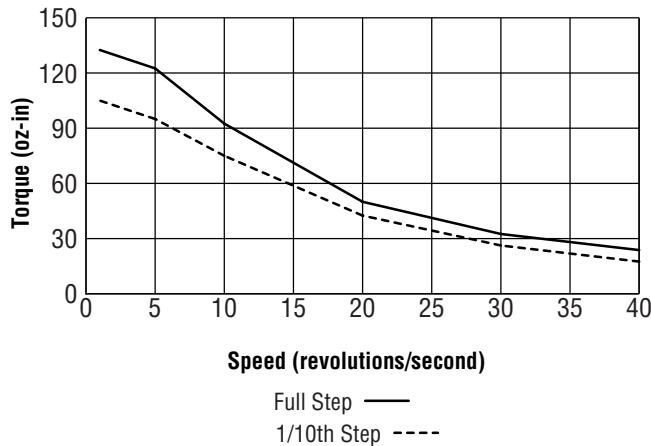

HT23-400 HIGH TORQUE MOTOR

Step Resolution: Full & 1/10th Step
Motor Current: 2.8 amp, Parallel Connected

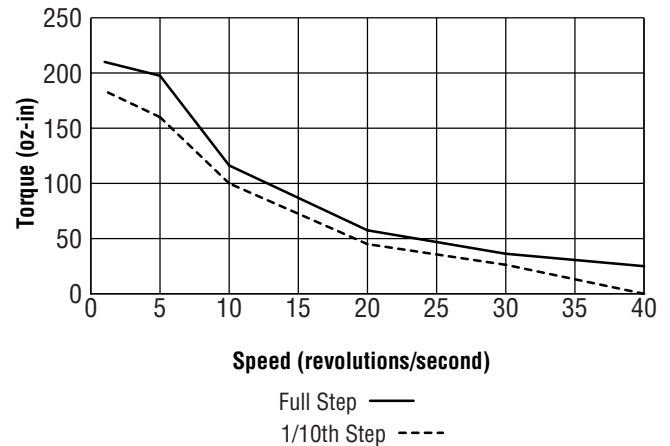

5034-334 MOTOR

Step Resolution: Full & 1/10th Step
Motor Current: 3.5 amp, Center Tap to End Connected

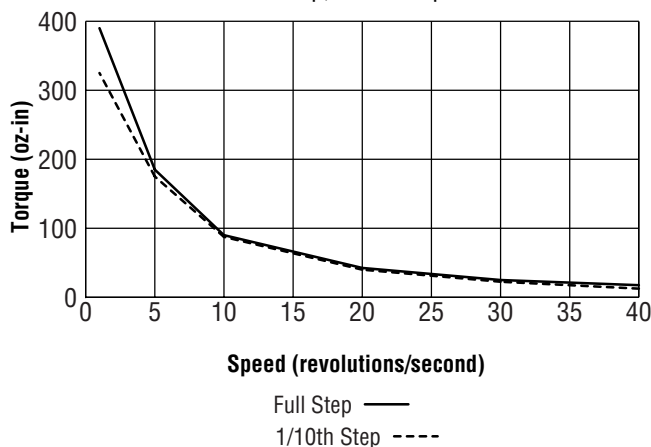

5034-348 MOTOR

Step Resolution: Full & 1/10th Step
Motor Current: 3.5 amp, Parallel Connected

