

# BLF6G10S-45

Power LDMOS transistor

Rev. 03 — 20 January 2010

Product data sheet

## 1. Product profile

### 1.1 General description

45 W LDMOS power transistor for base station applications at frequencies from 700 MHz to 1000 MHz.

**Table 1. Typical performance**

*RF performance at  $T_{case} = 25\text{ °C}$  in a common source class-AB production test circuit.*

Mode of operation	f (MHz)	V <sub>DS</sub> (V)	P <sub>L(AV)</sub> (W)	G <sub>p</sub> (dB)	η <sub>D</sub> (%)	ACPR (dBc)
2-carrier W-CDMA	920 to 960	28	1.0	23	8	-48.5 <sup>[1]</sup>

[1] Test signal: 3GPP; test model 1; 64 DPCH; PAR = 7.5 dB at 0.01 % probability on CCDF per carrier; carrier spacing 5 MHz.

#### CAUTION



This device is sensitive to ElectroStatic Discharge (ESD). Therefore care should be taken during transport and handling.

### 1.2 Features

- Typical 2-carrier W-CDMA performance at frequencies of 920 MHz and 960 MHz, a supply voltage of 28 V and an I<sub>DQ</sub> of 350 mA:
  - ◆ Average output power = 1.0 W
  - ◆ Gain = 23 dB
  - ◆ Efficiency = 8 %
  - ◆ ACPR = -48.5 dBc
- Easy power control
- Integrated ESD protection
- Excellent ruggedness
- High efficiency
- Excellent thermal stability
- Designed for broadband operation (700 MHz to 1000 MHz)
- Internally matched for ease of use
- Compliant to Directive 2002/95/EC, regarding restriction of hazardous substances (RoHS)

### 1.3 Applications

- RF power amplifiers for W-CDMA base stations and multi carrier applications in the 700 MHz to 1000 MHz frequency range.

## 2. Pinning information

**Table 2. Pinning**

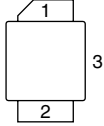
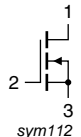
Pin	Description	Simplified outline	Symbol
1	drain		 sym112
2	gate		
3	source		

[1] Connected to flange.

## 3. Ordering information

**Table 3. Ordering information**

Type number	Package		
	Name	Description	Version
BLF6G10S-45	-	ceramic earless flanged package; 2 leads	SOT608B

## 4. Limiting values

**Table 4. Limiting values**

In accordance with the Absolute Maximum Rating System (IEC 60134).

Symbol	Parameter	Conditions	Min	Max	Unit
$V_{DS}$	drain-source voltage		-	65	V
$V_{GS}$	gate-source voltage		-0.5	+13	V
$I_D$	drain current		-	13	A
$T_{stg}$	storage temperature		-65	+150	°C
$T_j$	junction temperature		-	225	°C

## 5. Thermal characteristics

**Table 5. Thermal characteristics**

Symbol	Parameter	Conditions	Typ	Unit
$R_{th(j-case)}$	thermal resistance from junction to case	$T_{case} = 80\text{ °C};$ $P_L = 12.5\text{ W}$	1.7	K/W

## 6. Characteristics

**Table 6. Characteristics**

$T_j = 25\text{ }^\circ\text{C}$  per section; unless otherwise specified.

Symbol	Parameter	Conditions	Min	Typ	Max	Unit
$V_{(BR)DSS}$	drain-source breakdown voltage	$V_{GS} = 0\text{ V}; I_D = 0.5\text{ mA}$	65	-	-	V
$V_{GS(th)}$	gate-source threshold voltage	$V_{DS} = 10\text{ V}; I_D = 72\text{ mA}$	1.35	1.9	2.35	V
$V_{GSq}$	gate-source quiescent voltage	$V_{DS} = 28\text{ V}; I_D = 430\text{ mA}$	1.7	2.15	2.7	V
$I_{DSS}$	drain leakage current	$V_{GS} = 0\text{ V}; V_{DS} = 28\text{ V}$	-	-	1.4	$\mu\text{A}$
$I_{DSX}$	drain cut-off current	$V_{GS} = V_{GS(th)} + 3.75\text{ V}; V_{DS} = 10\text{ V}$	-	12.5	-	A
$I_{GSS}$	gate leakage current	$V_{GS} = 11\text{ V}; V_{DS} = 0\text{ V}$	-	-	140	nA
$g_{fs}$	forward transconductance	$V_{DS} = 10\text{ V}; I_D = 3.6\text{ A}$	-	5	-	S
$R_{DS(on)}$	drain-source on-state resistance	$V_{GS} = V_{GS(th)} + 3.75\text{ V}; I_D = 2.52\text{ A}$	-	0.2	-	$\Omega$

## 7. Application information

**Table 7. Application information**

Mode of operation: 2-carrier W-CDMA; PAR 7.5 dB at 0.01 % probability on CCDF; 3GPP test model 1; 1-64 PDPCH;  $f_1 = 922.5\text{ MHz}; f_2 = 927.5\text{ MHz}; f_3 = 952.5\text{ MHz}; f_4 = 957.5\text{ MHz}$ ; RF performance at  $V_{DS} = 28\text{ V}; I_{Dq} = 350\text{ mA}; T_{case} = 25\text{ }^\circ\text{C}$ ; unless otherwise specified; in a class-AB production test circuit.

Symbol	Parameter	Conditions	Min	Typ	Max	Unit
$G_p$	power gain	$P_{L(AV)} = 1.0\text{ W}$	21.8	23	24.5	dB
$RL_{in}$	input return loss	$P_{L(AV)} = 1.0\text{ W}$	5.5	9	-	dB
$\eta_D$	drain efficiency	$P_{L(AV)} = 1.0\text{ W}$	7	8	-	%
ACPR	adjacent channel power ratio	$P_{L(AV)} = 1.0\text{ W}$	-	-48.5	-45.5	dBc

### 7.1 Ruggedness in class-AB operation

The BLF6G10S-45 is capable of withstanding a load mismatch corresponding to  $VSWR = 10 : 1$  through all phases under the following conditions:  $V_{DS} = 28\text{ V}; I_{Dq} = 350\text{ mA}; P_L = 35\text{ W (CW)}; f = 960\text{ MHz}$ .

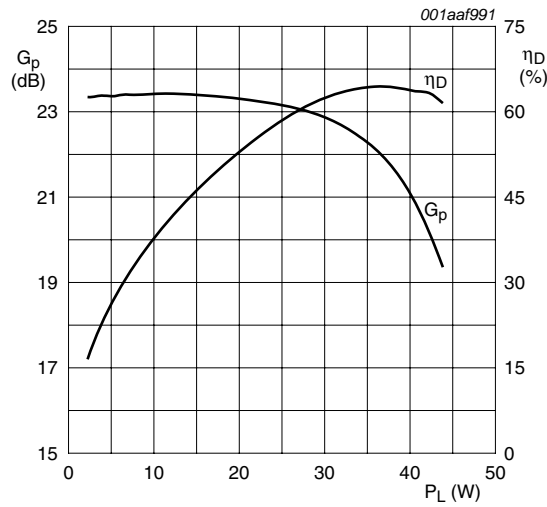

$V_{DS} = 28\text{ V}$ ;  $I_{Dq} = 350\text{ mA}$ ;  $f = 960\text{ MHz}$ .

**Fig 1. One-tone CW power gain and drain efficiency as functions of load power; typical values**

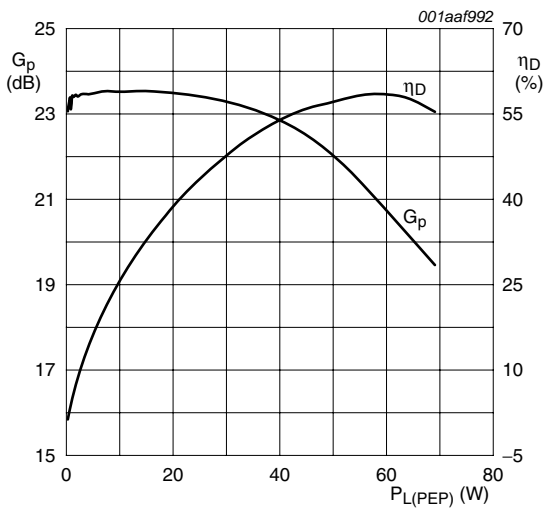

$V_{DS} = 28\text{ V}$ ;  $I_{Dq} = 350\text{ mA}$ ;  $f_1 = 960\text{ MHz}$ ;  
 $f_2 = 960.1\text{ MHz}$ .

**Fig 2. Two-tone CW power gain and drain efficiency as functions of peak envelope load power; typical values**

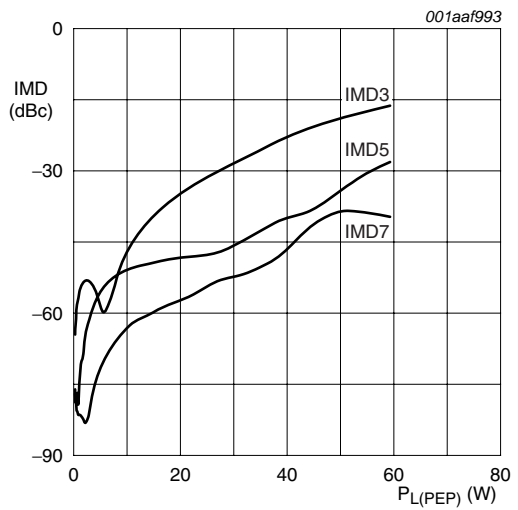

$V_{DS} = 28\text{ V}$ ;  $I_{Dq} = 350\text{ mA}$ ;  $f_1 = 960\text{ MHz}$ ;  
 $f_2 = 960.1\text{ MHz}$ .

**Fig 3. Intermodulation distortion as a function of peak envelope load power; typical values**

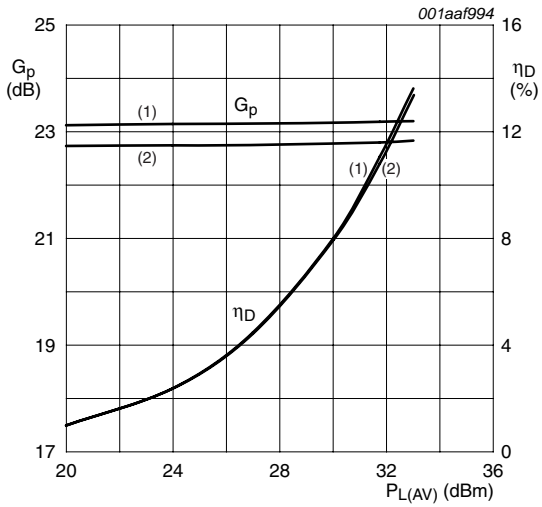

$V_{DS} = 28$  V;  $I_{Dq} = 350$  mA;  $f_1 = 952.5$  MHz;  
 $f_2 = 957.5$  MHz; carrier spacing 5 MHz.  
 (1)  $f = 955$  MHz.  
 (2)  $f = 925$  MHz.

**Fig 4. 2-carrier W-CDMA power gain and drain efficiency as functions of average load power; typical values**

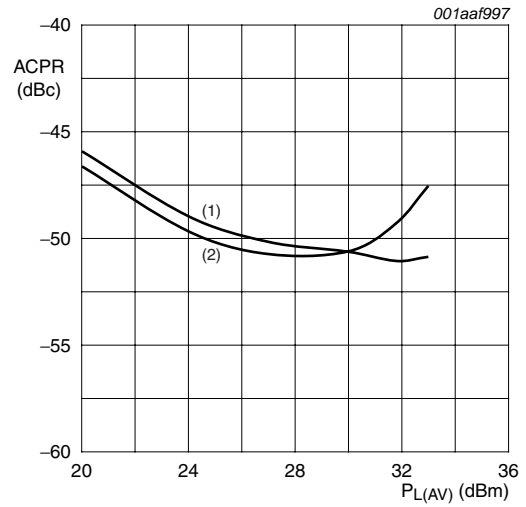

$V_{DS} = 28$  V;  $I_{Dq} = 350$  mA; carrier spacing 5 MHz.  
 (1)  $f = 955$  MHz.  
 (2)  $f = 925$  MHz.

**Fig 5. 2-carrier W-CDMA adjacent channel power ratio as function of average load power; typical values**

**8. Test information**

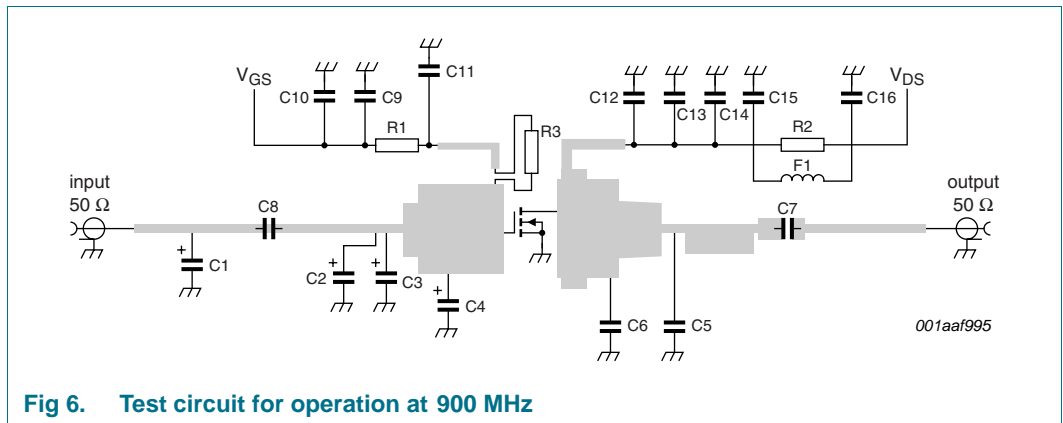

**Fig 6. Test circuit for operation at 900 MHz**

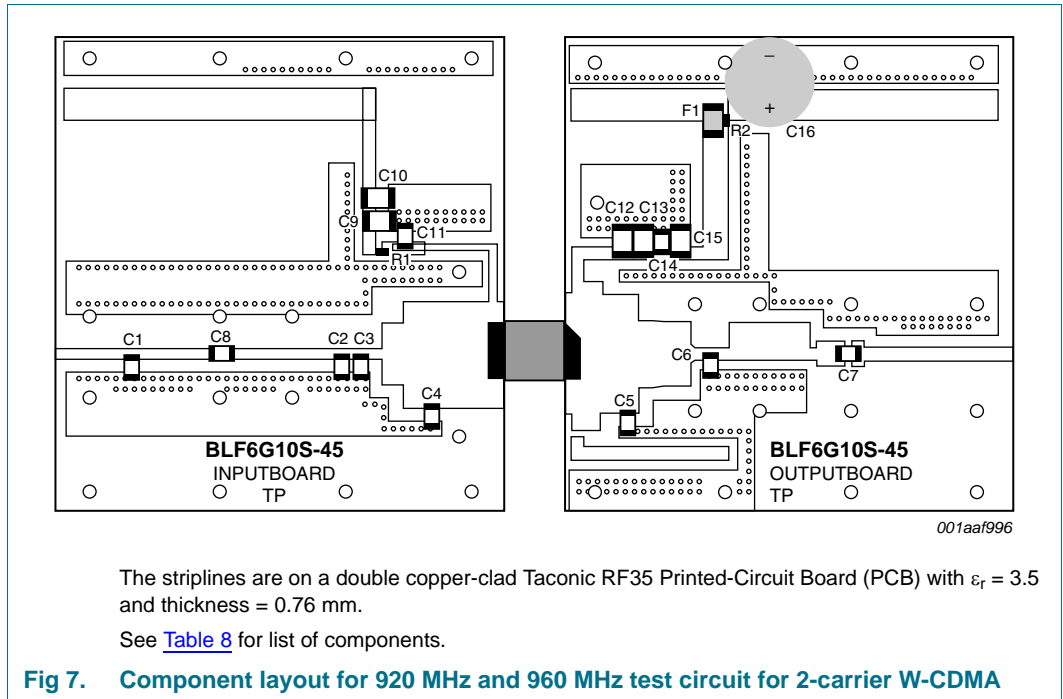

**Table 8. List of components (see [Figure 6](#) and [Figure 7](#)).**

All capacitors should be soldered vertically.

Component	Description	Value	Remarks
C1	multilayer ceramic chip capacitor	3.0 pF	[1]
C2	multilayer ceramic chip capacitor	1 pF	[1]
C3	multilayer ceramic chip capacitor	6.2 pF	[1]
C4	multilayer ceramic chip capacitor	1.8 pF	[1]
C5	multilayer ceramic chip capacitor	1.0 pF	[1]
C6	multilayer ceramic chip capacitor	6.8 pF	[1]
C7	multilayer ceramic chip capacitor	6.8 pF	[1]
C8, C11, C14	multilayer ceramic chip capacitor	68 pF	[1]
C9, C10, C12, C13	multilayer ceramic chip capacitor	330 nF; 50 V	[2]
C15	multilayer ceramic chip capacitor	4.5 $\mu$ F; 50 V	[2]
C16	Electrolytic capacitor	220 $\mu$ F	
F1	Ferrite SMD bead	-	Ferroxcube BDS 3/3/8.9-4S2 or equivalent
Q3	BLF6G10S-45	-	
R1	SMD resistor	4.7 $\Omega$ ; 0.1 W	
R2	SMD resistor	6.8 $\Omega$ ; 0.1 W	

[1] American Technical Ceramics type 100B or capacitor of same quality.

[2] TDK or capacitor of same quality.

**9. Package outline**

Ceramic earless flanged package; 2 leads

SOT608B

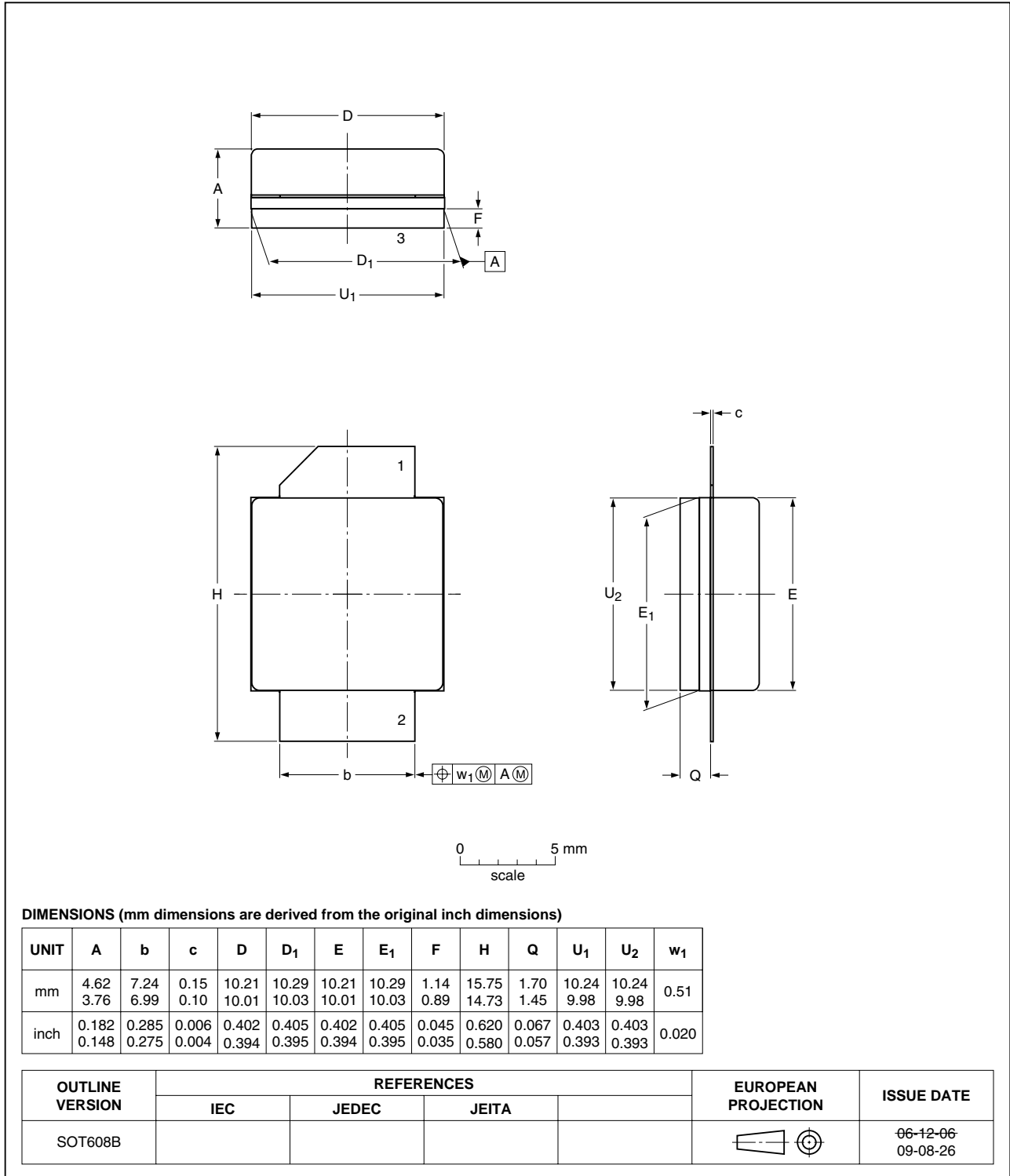

**Fig 8. Package outline SOT608B**

## 10. Abbreviations

Table 9. Abbreviations

Acronym	Description
3GPP	3rd Generation Partnership Project
CCDF	Complementary Cumulative Distribution Function
CW	Continuous Waveform
DPCH	Dedicated Physical CHannel
LDMOS	Laterally Diffused Metal Oxide Semiconductor
PAR	Peak-to-Average power Ratio
PDPCH	transmission Power of the Dedicated Physical CHannel
RF	Radio Frequency
SMD	Surface-Mount Device
VSWR	Voltage Standing-Wave Ratio
W-CDMA	Wideband Code Division Multiple Access

## 11. Revision history

Table 10. Revision history

Document ID	Release date	Data sheet status	Change notice	Supersedes
BLF6G10S-45_3	20100120	Product data sheet	-	BLF6G10S-45_2
Modifications:	<ul style="list-style-type: none"> <li>• <a href="#">Section 1.1 "General description"</a> lower frequency range extended to 700 MHz from 800 MHz.</li> <li>• <a href="#">Section 1.2 "Features"</a> lower frequency range extended to 700 MHz from 800 MHz.</li> <li>• <a href="#">Section 1.3 "Applications"</a> lower frequency range extended to 700 MHz from 800 MHz.</li> <li>• <a href="#">Section 12 "Legal information"</a> export control disclaimer added.</li> </ul>			
BLF6G10S-45_2	20090210	Product data sheet	-	BLF6G10S-45_1
BLF6G10S-45_1	20070223	Preliminary data sheet	-	-



## 12. Legal information

### 12.1 Data sheet status

Document status <sup>[1][2]</sup>	Product status <sup>[3]</sup>	Definition
Objective [short] data sheet	Development	This document contains data from the objective specification for product development.
Preliminary [short] data sheet	Qualification	This document contains data from the preliminary specification.
Product [short] data sheet	Production	This document contains the product specification.

[1] Please consult the most recently issued document before initiating or completing a design.

[2] The term 'short data sheet' is explained in section "Definitions".

[3] The product status of device(s) described in this document may have changed since this document was published and may differ in case of multiple devices. The latest product status information is available on the Internet at URL <http://www.nxp.com>.

### 12.2 Definitions

**Draft** — The document is a draft version only. The content is still under internal review and subject to formal approval, which may result in modifications or additions. NXP Semiconductors does not give any representations or warranties as to the accuracy or completeness of information included herein and shall have no liability for the consequences of use of such information.

**Short data sheet** — A short data sheet is an extract from a full data sheet with the same product type number(s) and title. A short data sheet is intended for quick reference only and should not be relied upon to contain detailed and full information. For detailed and full information see the relevant full data sheet, which is available on request via the local NXP Semiconductors sales office. In case of any inconsistency or conflict with the short data sheet, the full data sheet shall prevail.

### 12.3 Disclaimers

**General** — Information in this document is believed to be accurate and reliable. However, NXP Semiconductors does not give any representations or warranties, expressed or implied, as to the accuracy or completeness of such information and shall have no liability for the consequences of use of such information.

**Right to make changes** — NXP Semiconductors reserves the right to make changes to information published in this document, including without limitation specifications and product descriptions, at any time and without notice. This document supersedes and replaces all information supplied prior to the publication hereof.

**Suitability for use** — NXP Semiconductors products are not designed, authorized or warranted to be suitable for use in medical, military, aircraft, space or life support equipment, nor in applications where failure or

malfunction of an NXP Semiconductors product can reasonably be expected to result in personal injury, death or severe property or environmental damage. NXP Semiconductors accepts no liability for inclusion and/or use of NXP Semiconductors products in such equipment or applications and therefore such inclusion and/or use is at the customer's own risk.

**Applications** — Applications that are described herein for any of these products are for illustrative purposes only. NXP Semiconductors makes no representation or warranty that such applications will be suitable for the specified use without further testing or modification.

**Limiting values** — Stress above one or more limiting values (as defined in the Absolute Maximum Ratings System of IEC 60134) may cause permanent damage to the device. Limiting values are stress ratings only and operation of the device at these or any other conditions above those given in the Characteristics sections of this document is not implied. Exposure to limiting values for extended periods may affect device reliability.

**Terms and conditions of sale** — NXP Semiconductors products are sold subject to the general terms and conditions of commercial sale, as published at <http://www.nxp.com/profile/terms>, including those pertaining to warranty, intellectual property rights infringement and limitation of liability, unless explicitly otherwise agreed to in writing by NXP Semiconductors. In case of any inconsistency or conflict between information in this document and such terms and conditions, the latter will prevail.

**Export control** — This document as well as the item(s) described herein may be subject to export control regulations. Export might require a prior authorization from national authorities.

### 12.4 Trademarks

Notice: All referenced brands, product names, service names and trademarks are the property of their respective owners.

## 13. Contact information

For more information, please visit: <http://www.nxp.com>

For sales office addresses, please send an email to: [salesaddresses@nxp.com](mailto:salesaddresses@nxp.com)

**14. Contents**

**1 Product profile . . . . . 1**

1.1 General description . . . . . 1

1.2 Features . . . . . 1

1.3 Applications . . . . . 2

**2 Pinning information . . . . . 2**

**3 Ordering information . . . . . 2**

**4 Limiting values . . . . . 2**

**5 Thermal characteristics . . . . . 2**

**6 Characteristics . . . . . 3**

**7 Application information . . . . . 3**

7.1 Ruggedness in class-AB operation . . . . . 3

**8 Test information . . . . . 5**

**9 Package outline . . . . . 7**

**10 Abbreviations . . . . . 8**

**11 Revision history . . . . . 8**

**12 Legal information . . . . . 9**

12.1 Data sheet status . . . . . 9

12.2 Definitions . . . . . 9

12.3 Disclaimers . . . . . 9

12.4 Trademarks . . . . . 9

**13 Contact information . . . . . 9**

**14 Contents . . . . . 10**

Please be aware that important notices concerning this document and the product(s) described herein, have been included in section 'Legal information'.



© NXP B.V. 2010.

All rights reserved.

For more information, please visit: <http://www.nxp.com>

For sales office addresses, please send an email to: [salesaddresses@nxp.com](mailto:salesaddresses@nxp.com)

Date of release: 20 January 2010

Document identifier: BLF6G10S-45\_3