



1.0mm Female Header SMT Type H=2.1mm

MATERIAL

Insulator : High Temperature Polyester
Contact Pin : Phosphor Bronze

SPECIFICATION

Current Rate : 1 AMP
Insulation Resistance : 5000MΩMin.
Contact Resistance : 20mΩMax.
Operation Temperature : -40°C to + 105°C



Detail Dimensions

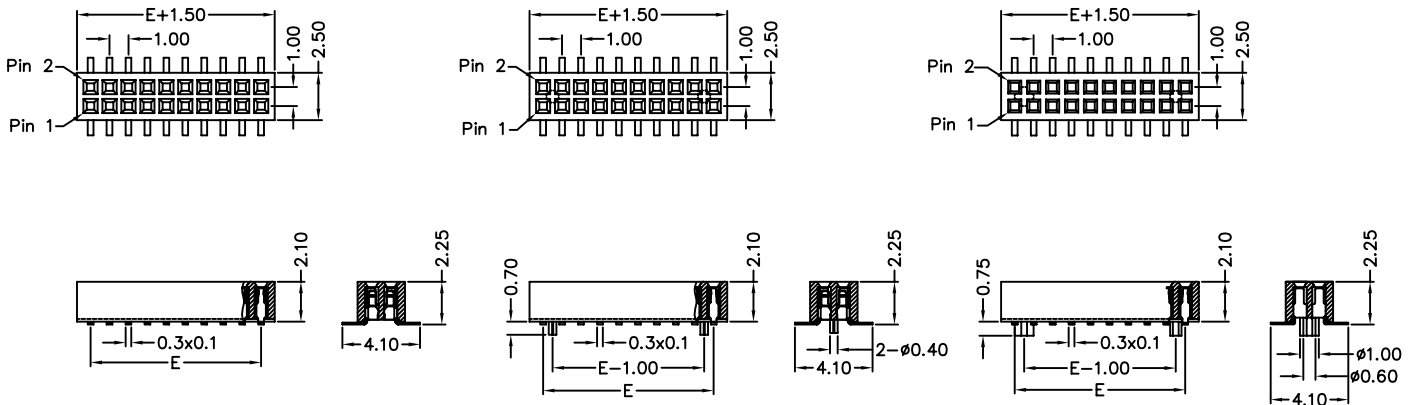

Recommended P.C.B Layout

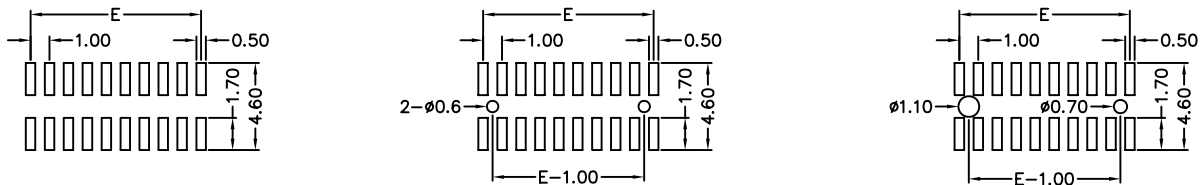

Order Information

650-x 2 - xx G B xx
1 2 3

- 7: Green Product
9: Green Product High Temp
- No. of contacts per row
- Pinrex internal code

Standard Parts	Type
650-x2-xxGB10	without posts
650-x2-xxGB12	with two posts
650-x2-xxGB22	with posts

Number Of Contacts

Unit: mm

Poles	DIM E	Poles	DIM E	Poles	DIM E	Poles	DIM E	Poles	DIM E	Poles	DIM E	Poles	DIM E	Poles	DIM E
		8	7.00	15	14.00	22	21.00	29	28.00	36	35.00	43	42.00	50	49.00
		9	8.00	16	15.00	23	22.00	30	29.00	37	36.00	44	43.00		
		10	9.00	17	16.00	24	23.00	31	30.00	38	37.00	45	44.00		
4	3.00	11	10.00	18	17.00	25	24.00	32	31.00	39	38.00	46	45.00		
5	4.00	12	11.00	19	18.00	26	25.00	33	32.00	40	39.00	47	46.00		
6	5.00	13	12.00	20	19.00	27	26.00	34	33.00	41	40.00	48	47.00		
7	6.00	14	13.00	21	20.00	28	27.00	35	34.00	42	41.00	49	48.00		