

Features

- **Industry Standard mini-Serial ATA (miniSATA or mSATA) Host Interface**
 - SATA 1.5 Gb/s or SATA 3.0 Gb/s ¹⁾
 - ATA/ATAPI-8 compliant
 - Supports 48-bit address feature set
- **Performance**
 - Sequential data read - Up to 110 MByte/sec*
 - Sequential data write - Up to 60 MByte/sec*

* measured using 128 KByte transfer size
- **Power Management**
 - 3.3V power supply
 - Host SATA interface power management
 - Immediate disabling of unused circuitry without host intervention
- **Power Specifications** ²⁾
 - Active mode:
 - 1070mW typical (GLS86FB064G2)
 - 820mW typical (GLS86FB032G2)
 - 800mW typical (GLS86FB016G2)
 - 760mW typical (GLS86FB008G2)
 - Idle/Standby mode: as low as 380mW typical
 - Sleep mode: as low as 110mW typical
- **Expanded Data Protection**
 - Added data security through user-selectable protection zones
- **Integrated Voltage Detector**
 - Detects supply voltage fluctuations and generates reset during power-up and power-down to prevent inadvertent writes
- **Supports SMART Commands**
- **Supports TRIM Commands**
- **20-Byte Serial Number**
 - Factory pre-programmed 10-Byte unique ID
 - User-programmable 10-Byte ID
- **Robust Built-in ECC**
- **NAND Configuration**
 - 2 bits per cell (MLC)
- **Temperature Range**
 - Industrial: -40°C to 85°C
- **JEDEC standard MO-300 mSATA form factor**
 - 29.85 mm x 50.80 mm x 4.8 mm
- **All Devices are RoHS Compliant**
 - 1) Current product revision supports SATA Revision 1.x with host transfer rate of up to 1.5 Gb/s (i.e. SATA 1.5 Gb/s). SATA 3.0 Gb/s refers to SATA Revision 2.x and will be supported by our planned future product revisions.
 - 2) For management of the Sleep Mode, please refer to "SATA NANDrive Application Design Guide."

Product Description

The GLS86FB008G2 / 016G2 / 1032G2 / 064G2 Industrial Temperature miniSATA (mSATA) ArmourDrive™ solid state drive modules (referred to as "mSATA ArmourDrive" in this fact sheet) are high-reliability, fully integrated solid state drives. They combine an 8, 16, 32 or 64 GByte SATA NANDrive™ and power interrupt data protection circuit on a printed circuit board (PCB) module. These products are ideal for portable applications that require removable form factor and more reliable data storage.

SATA-interface solid state mass storage technology is widely used in portable and industrial computers, set-top boxes, test and measurement instrumentation, multi-functional printers, video and audio recorders, network servers and car infotainment systems.

mSATA ArmourDrive is a removable solid state drive (SSD) that provides the functionality and compatibility of a complete SATA hard disk drive (HDD) in a 29.85 mm x 50.80 mm form factor. These products surpass traditional storage in their small size, security, reliability, ruggedness and low power consumption.

The integrated NAND flash controller with built-in advanced NAND management firmware communicates with the host through the standard SATA protocol. It does not require any additional or proprietary software such as the Flash File System (FFS) and Memory Technology Driver (MTD).

mSATA ArmourDrive is pre-programmed with a 10-Byte unique serial ID and has the option of programming an additional 10-Byte serial ID for even greater system security.

mSATA ArmourDrive's advanced NAND management technology enhances data reliability and security, improves endurance and accurately estimates the remaining life of the NAND flash devices. This innovative technology combines robust NAND controller hardware error correction capabilities with advanced wear-leveling algorithms and bad block management to significantly extend the life of the product.

mSATA ArmourDrive is offered in a standard JEDEC 52-pin PCB module form factor.

1.0 GENERAL DESCRIPTION

Each mSATA ArmourDrive module contains a NANDrive multi-chip package, which integrates a SATA NAND flash memory controller with up to eight discrete NAND flash die. Refer to Figure 2-1 for the mSATA ArmourDrive block diagram.

1.1 Optimized mSATA ArmourDrive

The heart of mSATA ArmourDrive is the SATA NAND flash memory controller which translates standard SATA signals into flash media data and control signals. The following components contribute to mSATA ArmourDrive's operation.

1.1.1 Microcontroller Unit (MCU)

The MCU translates SATA commands into data and control signals required for flash media operation.

1.1.2 Internal Direct Memory Access (DMA)

mSATA ArmourDrive uses internal DMA allowing instant data transfer from/to buffer to/from flash media. This implementation eliminates microcontroller overhead associated with the traditional, firmware-based approach, thereby increasing the data transfer rate.

1.1.3 Power Management Unit (PMU)

The PMU controls the power consumption of mSATA ArmourDrive. The PMU dramatically reduces the power consumption of mSATA ArmourDrive by putting the part of the circuitry that is not in operation into sleep mode.³⁾

The Flash File System handles inadvertent power interrupts and has auto-recovery capability to ensure mSATA ArmourDrive firmware integrity. For regular power management, the host must send an IDLE_IMMEDIATE command and wait for command ready before powering down mSATA ArmourDrive.

³⁾ For management of the Sleep Mode, please refer to "SATA NANDrive Application Design Guide."

1.1.4 Embedded Flash File System

The embedded flash file system is an integral part of mSATA ArmourDrive. It contains MCU firmware that performs the following tasks:

1. Translates host side signals into flash media writes and reads
2. Provides flash media wear leveling to spread the flash writes across all memory address space to increase the longevity of flash media
3. Keeps track of data file structures
4. Manages system security for the selected protection zones

1.1.5 Power Interrupt Data Protection

Dedicated power failure detection and backup power circuitry are built in to prevent data integrity issues due to sudden power interruptions.

1.1.6 Error Correction Code (ECC)

High performance is achieved through optimized hardware error detection and correction.

1.1.7 Serial Communication Interface (SCI)

The Serial Communication Interface (SCI) is designed for error reporting. During the product development stage, it is recommended to provide the SCI port on the PCB to aid in design validation.

1.1.8 Multi-tasking Interface

The multi-tasking interface enables concurrent Read, Program and Erase operations to multiple NAND flash media.

1.2 Advanced NAND Management

mSATA ArmourDrive's integrated controller uses advanced wear-leveling algorithms to substantially increase the longevity of NAND flash media. Wear caused by data writes is evenly distributed in all or select blocks in the device that prevents "hot spots" in locations that are programmed and erased extensively. This effective wear-leveling technique results in optimized device endurance, enhanced data retention and higher reliability required by long-life applications.

2.0 FUNCTIONAL BLOCKS

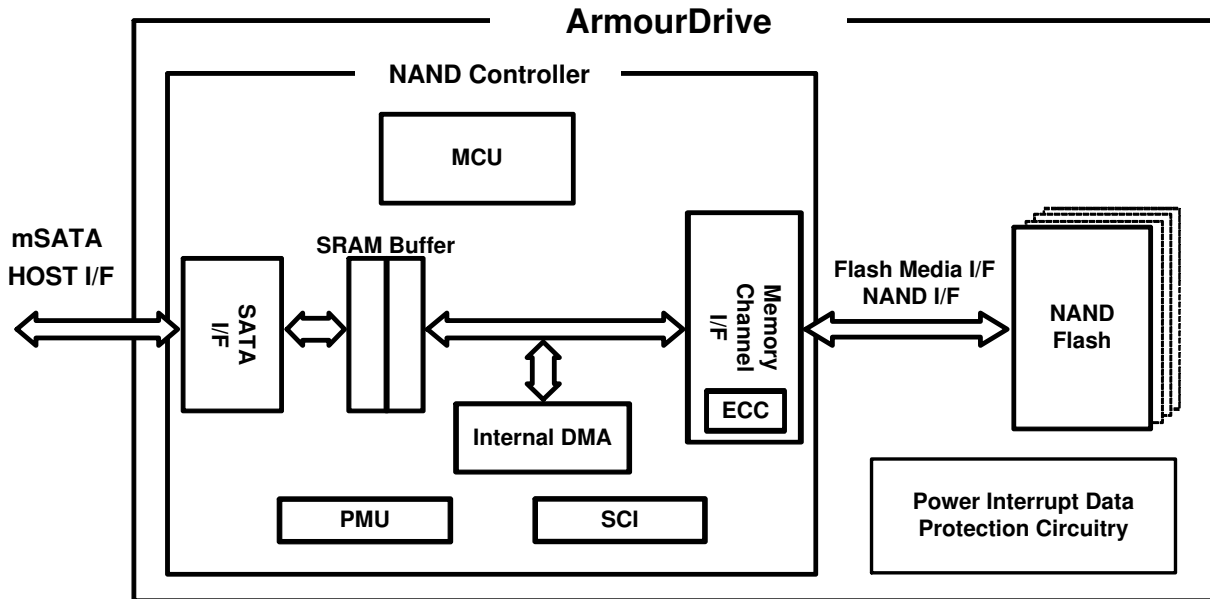
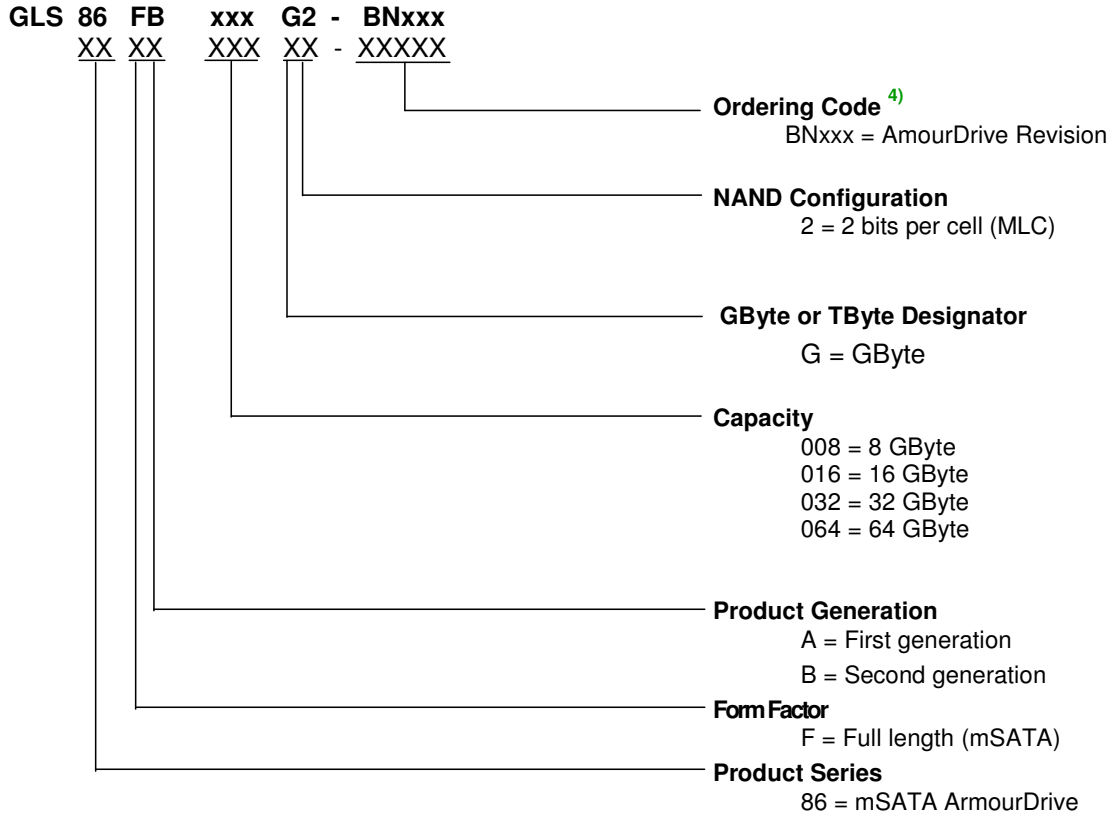

Figure 2-1: mSATA ArmourDrive Block Diagram

3.0 APPENDIX

3.1 Product Ordering Information



4) Note that the top side marking on the package typically does not include ordering codes (e.g. BNxxx), unless it is a special custom specification (C-SPEC) required by the end-customer to be marked on the device.

Valid Combinations

Valid product combinations are those that are in the mass production or will be in the mass production. Consult your Greenliant sales representative to confirm availability of the valid combinations and to determine availability of new product combinations.

Table 3-1: mSATA ArmourDrive Product Valid Ordering Numbers

Capacity	Operating Temperature	Part Number	Form Factor
8GB	Industrial (-40 °C to 85 °C)	GLS86FB008G2-BN002	JEDEC MO-300 (full length)
16GB	Industrial (-40 °C to 85 °C)	GLS86FB016G2-BN002	JEDEC MO-300 (full length)
32GB	Industrial (-40 °C to 85 °C)	GLS86FB032G2-BN002	JEDEC MO-300 (full length)
64GB	Industrial (-40 °C to 85 °C)	GLS86FB064G2-BN002	JEDEC MO-300 (full length)

3.2 Board Diagrams

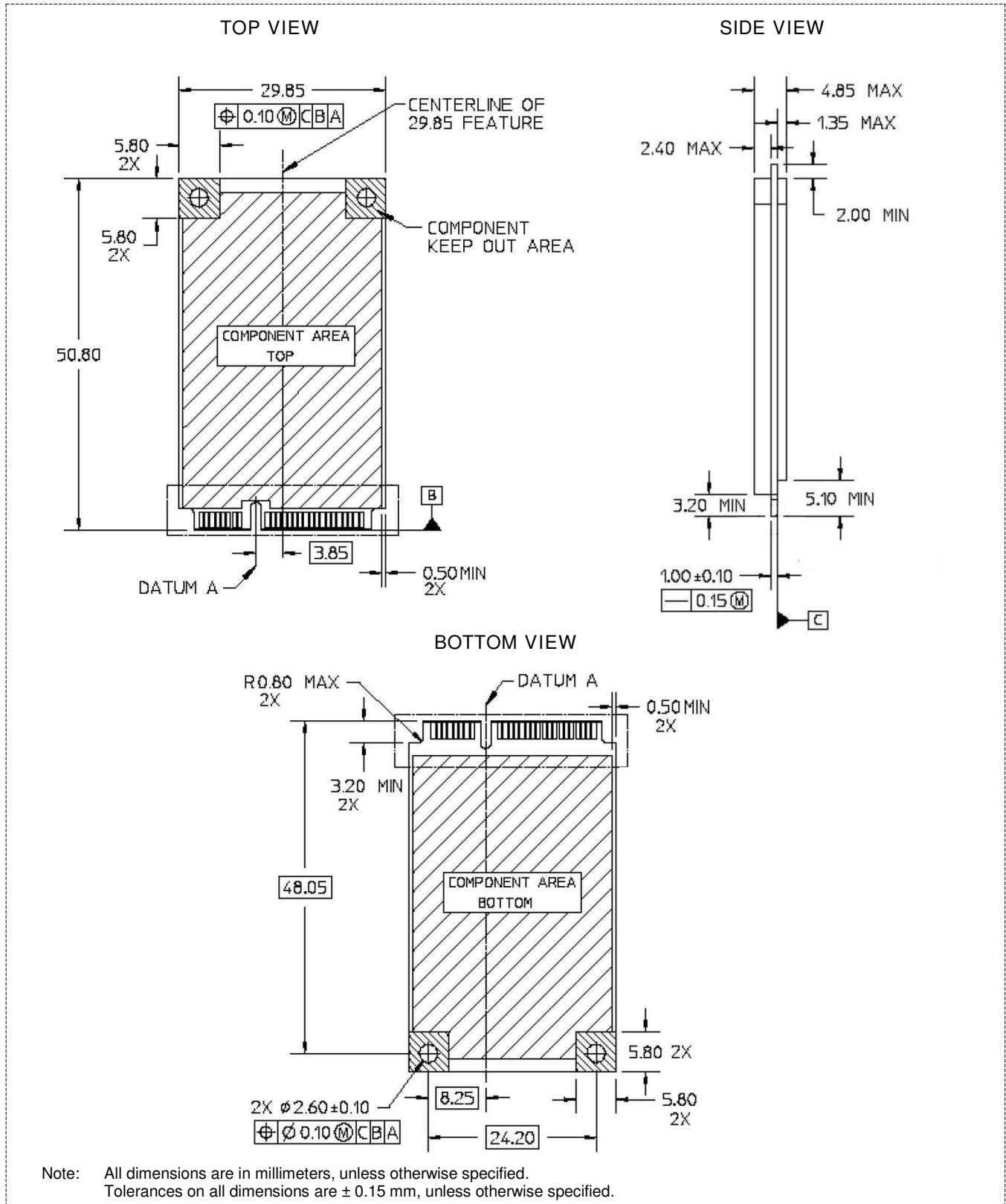

Figure 3-1: mSATA ArmourDrive Dimensions

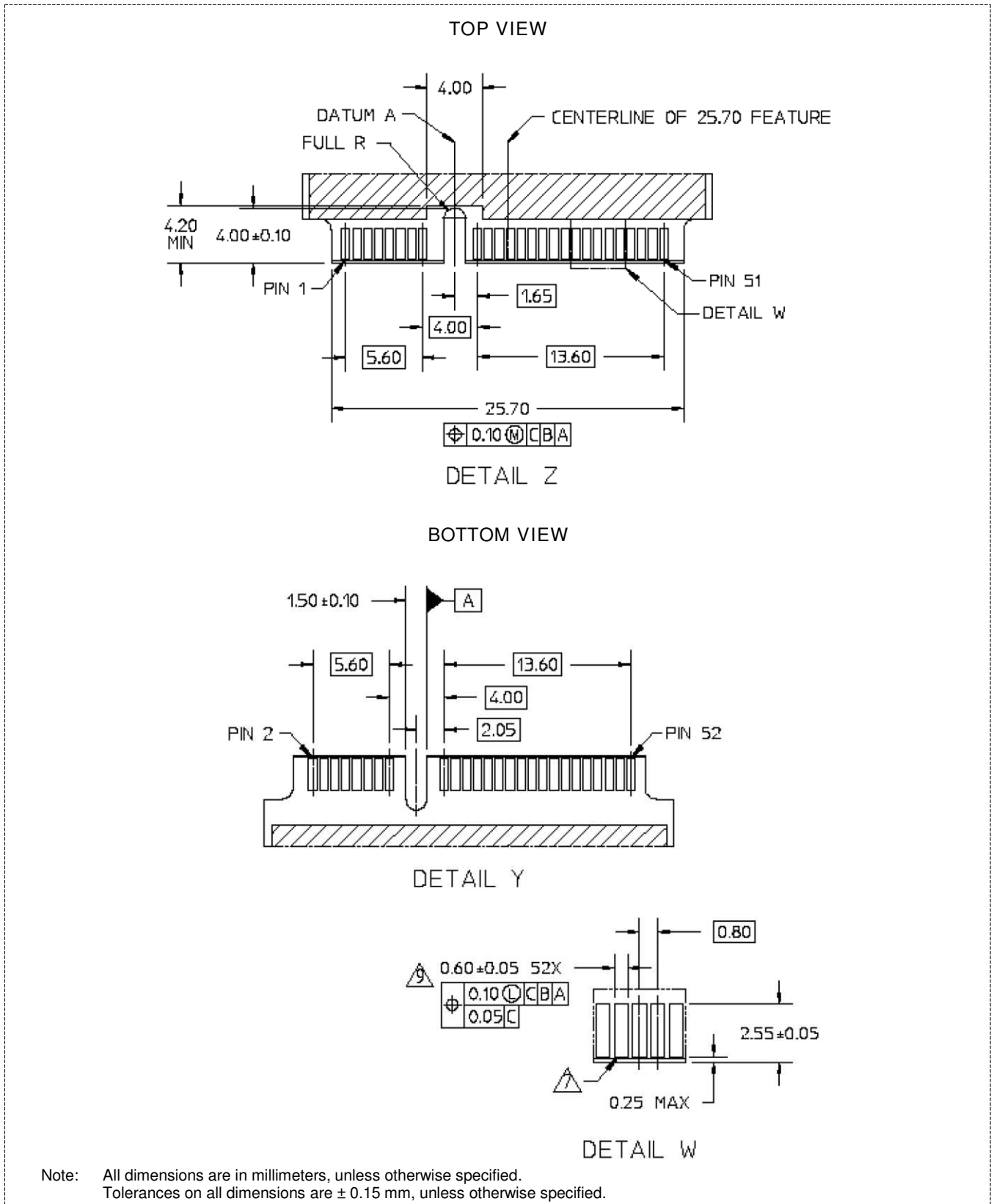

Figure 2-2: mSATA ArmourDrive Connector

3.3 Revision History

Table 3-2: Revision History

Revision	Description	Date
01.000	Initial release as Fact Sheet for GLS86FA008G2 / 016G2 / 032G2 / 064G2	July 22, 2013
01.100	Updated Ordering Code in Section 3.1	August 05, 2013
01.200	Updated Power Specifications	October 04, 2013
01.201	Fixed typos on first page	December 10, 2013

© 2013 Greenliant Systems. All rights reserved.

Greenliant and the Greenliant logo are registered trademarks, and ArmourDrive and NANDrive are trademarks of Greenliant Systems. All other trademarks and registered trademarks are the property of their respective owners.

Specifications are subject to change without notice. Memory sizes denote raw storage capacity; actual usable capacity may be less.

Greenliant makes no warranty for the use of its products other than those expressly contained in the Greenliant Terms and Conditions of Sale.

www.greenliant.com