

# Single High Side Switch (4.0 mOhm), PWM clock up to 60 kHz

The 34981 is a high frequency, self-protected 4.0 mΩ R<sub>DS(ON)</sub> high side switch used to replace electromechanical relays, fuses, and discrete devices in power management applications.

The 34981 can be controlled by pulse-width modulation (PWM) with a frequency up to 60 kHz. It is designed for harsh environments, and it includes self-recovery features. The 34981 is suitable for loads with high inrush current, as well as motors and all types of resistive and inductive loads.

The 34981 is packaged in a 12 x 12 mm non-leaded power-enhanced PQFN package with exposed tabs.

This device is powered by SMARTMOS technology.

### Features

- Single 4.0 mΩ R<sub>DS(ON)</sub> maximum high side switch
- PWM capability up to 60 kHz with duty cycle from 5% to 100%
- Very low standby current
- Slew-rate control with external capacitor
- Overcurrent and overtemperature protection, undervoltage shutdown, and fault reporting
- Reverse supply protection
- Gate drive signal for external low side N-channel MOSFET with protection features
- Output current monitoring
- Temperature feedback

**34981  
Industrial**

**HIGH SIDE SWITCH**

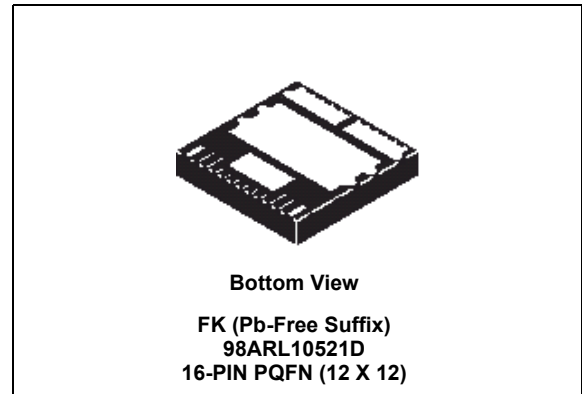

### Applications:

- DC motors
- Solenoids
- Power distribution
- Heating elements
- Pumps

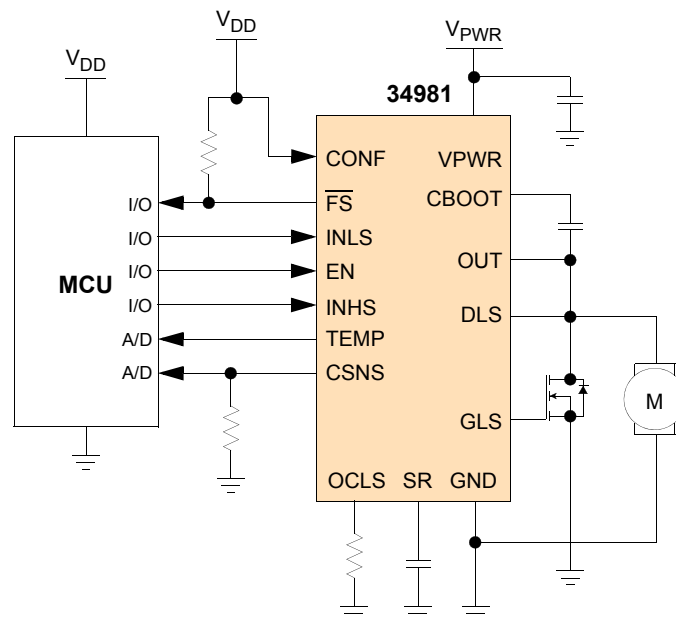

**Figure 1. 34981 Simplified Application Diagram**

Freescale Semiconductor, Inc. reserves the right to change the detail specifications, as may be required, to permit improvements in the design of its products.

© Freescale Semiconductor, Inc., 2013. All rights reserved.

## ORDERABLE PARTS

**Table 1. Orderable Part Variations**

Part Number <sup>(1)</sup>	Notes	Temperature (T <sub>A</sub> )	Package
MC34981ABHFK		-40 to 125 °C	16 PQFN

## Notes

1. To Order parts in Tape & Reel, add the R2 suffix to the part number.

## INTERNAL BLOCK DIAGRAM

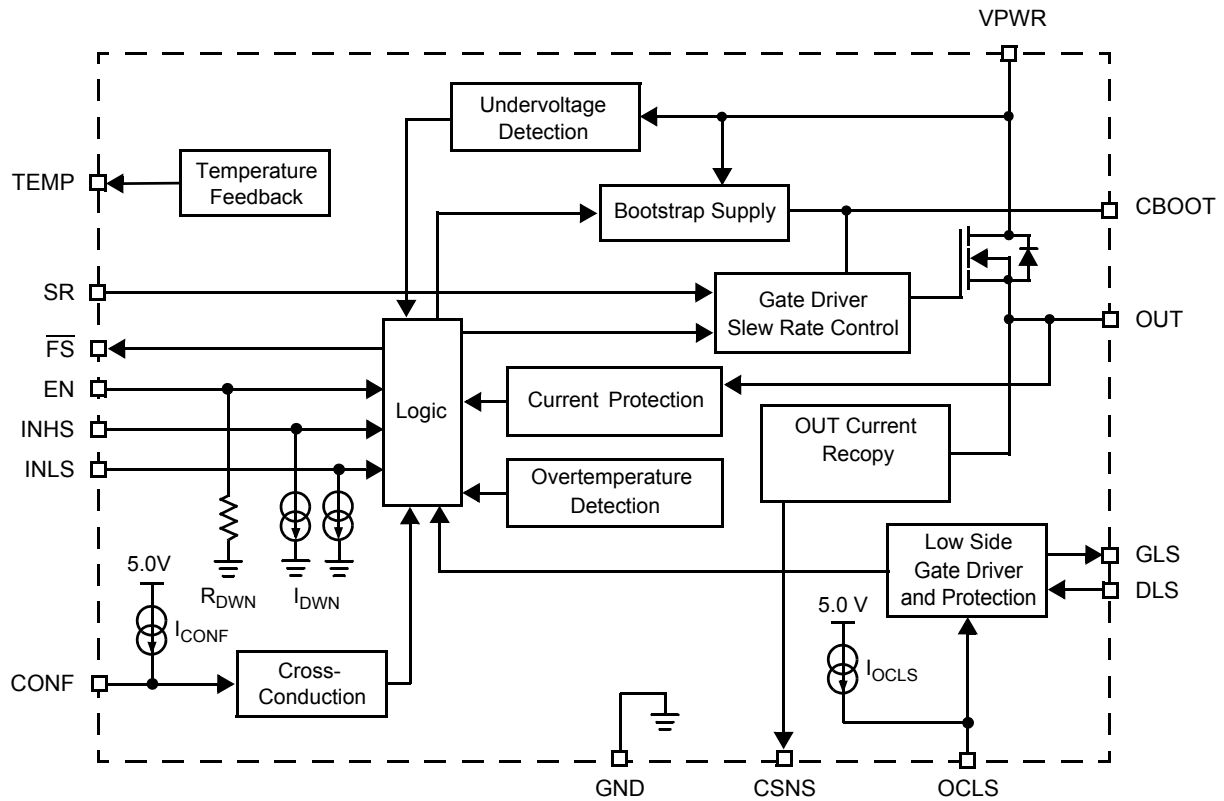
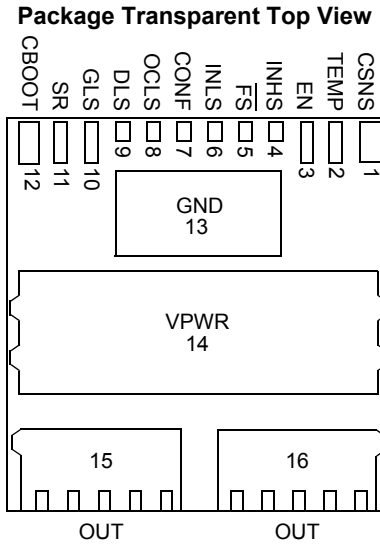

Figure 2. 34981 Simplified Internal Block Diagram

## PIN CONNECTIONS



**Figure 3. Pin Connections**

Descriptions of the pins listed in the table below can be found in the Functional Description section located on [page 15](#).

**Table 2. PIN DEFINITIONS**

Pin Number	Pin Name	Pin Function	Formal Name	Definition
1	CSNS	Reports	Output Current Monitoring	This pin is used to generate a ground-referenced voltage for the microcontroller (MCU) to monitor output current.
2	TEMP	Reports	Temperature Feedback	This pin is used by the MCU to monitor board temperature.
3	EN	Input	Enable (Active High)	This pin is used to place the device in a low-current Sleep mode.
4	INHS	Input	Serial Input High Side	This input pin is used to control the output of the device.
5	FS	Reports	Fault Status (Active Low)	This pin monitors fault conditions and is active LOW.
6	INLS	Input	Serial Input Low Side	This pin is used to control an external low side N-channel MOSFET.
7	CONF	Input	Configuration Input	This input manages MOSFET N-channel cross-conduction.
8	OCLS	Input	Low Side Overload	This pin sets the $V_{DS}$ protection level of the external low side MOSFET.
9	DLS	Input	Drain Low Side	This pin is the drain of the external low side N-channel MOSFET.
10	GLS	Output	Low Side Gate	This output pin drives the gate of the external low side N-channel MOSFET.
11	SR	Input	Slew Rate Control	This pin controls the output slew rate.
12	CBOOT	Input	Bootstrap Capacitor	This pin provides the high pulse current to drive the device.
13	GND	Ground	Ground	This is the ground pin of the device.
14	VPWR	Input	Positive Power Supply	This pin is the source input of operational power for the device.
15, 16	OUT	Output	Output	These pins provide a protected high side power output to the load connected to the device.

## ELECTRICAL CHARACTERISTICS

## MAXIMUM RATINGS

Table 3. Maximum Ratings

All voltages are with respect to ground unless otherwise noted.

Rating	Symbol	Value	Unit
<b>ELECTRICAL RATINGS</b>			
Power Supply Voltage Steady-state	$V_{PWR}$	-16 to 41	V
Input/Output Pins Voltage <sup>(2)</sup>	INHS, INLS, $\overline{CONF}$ , CSNS, $\overline{FS}$ , TEMP, EN	-0.3 to 7.0	V
Output Voltage Positive Negative	$V_{OUT}$	41.0 -5.0	V
Continuous Output Current <sup>(3)</sup>	$I_{OUT}$	40.0	A
CSNS Input Clamp Current	$I_{CL(CSNS)}$	15.0	mA
EN Input Clamp Current	$I_{CL(EN)}$	2.5	mA
SR Voltage	$V_{SR}$	-0.3 to 54.0	V
$C_{BOOT}$ Voltage	$C_{BOOT}$	-0.3 to 54.0	V
OCLS Voltage	$V_{OCLS}$	-5.0 to 7.0	V
Low Side Gate Voltage	$V_{GLS}$	-0.3 to 15.0	V
Low Side Drain Voltage	$V_{DLS}$	-5.0 to 41.0	V
ESD Voltage <sup>(4)</sup> Human Body Model (HBM) Charge Device Model (CDM) Corner Pins (1, 12, 15, 16) All Other Pins (2-11, 13-14)	$V_{ESD}$	±2000 ±750 ±500	V

## Notes

- Exceeding voltage limits on INHS, INLS,  $\overline{CONF}$ , CSNS,  $\overline{FS}$ , TEMP, and EN pins may cause a malfunction or permanent damage to the device.
- Continuous high side output rating as long as maximum junction temperature is not exceeded. Calculation of maximum output current using package thermal resistance is required.
- ESD testing is performed in accordance with the Human Body Model (HBM) ( $C_{ZAP} = 100$  pF,  $R_{ZAP} = 1500$   $\Omega$ ) and the Charge Device Model (CDM), Robotic ( $C_{ZAP} = 4.0$  pF).

**Table 3. Maximum Ratings (continued)**

All voltages are with respect to ground unless otherwise noted.

Rating	Symbol	Value	Unit
<b>THERMAL RATINGS</b>			
Operating Temperature Ambient	$T_A$	-40 to 125	°C
Junction <sup>(5)</sup>	$T_J$	-40 to 150	
Storage Temperature	$T_{STG}$	-55 to 150	°C
Thermal Resistance <sup>(6)</sup> Junction to Power Die Case	$R_{\theta JC}$	1.0	°C/W
Junction to Ambient	$R_{\theta JA}$	30.0	
Peak Package Reflow Temperature During Reflow <sup>(7), (8)</sup>	$T_{PPRT}$	Note 8	°C

Notes

- To achieve high reliability over 10 years of continuous operation, the device's continuous operating junction temperature should not exceed 125 °C.
- Device mounted on a 2s2p test board per JEDEC JESD51-2.
- Pin soldering temperature limit is for 40 seconds maximum duration. Not designed for immersion soldering. Exceeding these limits may cause malfunction or permanent damage to the device.
- Freescale's Package Reflow capability meets Pb-free requirements for JEDEC standard J-STD-020. For Peak Package Reflow Temperature and Moisture Sensitivity Levels (MSL), Go to [www.freescale.com](http://www.freescale.com), search by part number [e.g. remove prefixes/suffixes and enter the core ID to view all orderable parts. (i.e. MC33xxx enter 33xxx), and review parametrics.

**STATIC ELECTRICAL CHARACTERISTICS**

**Table 4. Static Electrical Characteristics**

Characteristics noted under conditions  $6.0\text{ V} \leq V_{PWR} \leq 27\text{ V}$ ,  $-40\text{ }^{\circ}\text{C} \leq T_A \leq 125\text{ }^{\circ}\text{C}$ , unless otherwise noted. Typical values noted reflect the approximate parameter mean at  $T_A = 25\text{ }^{\circ}\text{C}$  under nominal conditions, unless otherwise noted.

Characteristic	Symbol	Min	Typ	Max	Unit
<b>POWER INPUT (VPWR)</b>					
Supply Voltage Range	$V_{PWR}$				V
Fully Operational		6.0	–	27.0	
Extended <sup>(9)</sup>		4.5	–	27.0	
VPWR Supply Current	$I_{PWR(ON)}$				mA
INHS = 1 and OUT Open, INLS = 0		–	10.0	12.0	
VPWR Supply Current	$I_{PWR(SBY)}$				mA
INHS = INLS = 0, EN = 5.0 V, OUT Connected to GND		–	10.0	12.0	
Sleep-state Supply Current	$I_{PWR(SLEEP)}$				$\mu\text{A}$
( $V_{PWR} < 14\text{ V}$ , EN = 0 V, OUT Connected to GND)					
$T_A = 25\text{ }^{\circ}\text{C}$		–	–	5.0	
$T_A = 125\text{ }^{\circ}\text{C}$		–	–	50.0	
Undervoltage Shutdown	$V_{PWR(UV)}$	2.0	4.0	4.5	V
Undervoltage Hysteresis	$V_{PWR(UVHYS)}$	0.05	0.15	0.3	V
<b>POWER OUTPUT (IOUT, VPWR)</b>					
Output Drain-to-Source ON Resistance ( $I_{OUT} = 20\text{ A}$ , $T_A = 25\text{ }^{\circ}\text{C}$ )	$R_{DS(ON)25}$				$\text{m}\Omega$
$V_{PWR} = 6.0\text{ V}$		–	–	6.0	
$V_{PWR} = 9.0\text{ V}$		–	–	5.0	
$V_{PWR} = 13.0\text{ V}$		–	–	4.0	
Output Drain-to-Source ON Resistance ( $I_{OUT} = 20\text{ A}$ , $T_A = 150\text{ }^{\circ}\text{C}$ )	$R_{DS(ON)150}$				$\text{m}\Omega$
$V_{PWR} = 6.0\text{ V}$		–	–	10.2	
$V_{PWR} = 9.0\text{ V}$		–	–	8.5	
$V_{PWR} = 13.0\text{ V}$		–	–	6.8	
Output Source-to-Drain ON Resistance ( $I_{OUT} = -20\text{ A}$ , $T_A = 25\text{ }^{\circ}\text{C}$ ) <sup>(10)</sup>	$R_{SD(ON)}$				$\text{m}\Omega$
$V_{PWR} = -12\text{ V}$		–	–	8.0	
Output Overcurrent Detection Level	$I_{OCH}$				A
$9.0\text{ V} < V_{PWR} < 16\text{ V}$		75	100	125	
Current Sense Ratio	$C_{SR}$				–
$9.0\text{ V} \leq V_{PWR} \leq 16\text{ V}$ , CSNS $\leq 4.5\text{ V}$		–	1/20000	–	
Current Sense Ratio ( $C_{SR}$ ) Accuracy	$C_{SR\_ACC}$				%
$9.0\text{ V} \leq V_{PWR} \leq 16\text{ V}$ , CSNS $\leq 4.5\text{ V}$					
Output Current					
5.0 A		-20	–	20	
15 A, 20 A, and 30 A		-15	–	15	

Notes

- OUT can be commanded fully on, PWM is available at room. Low Side Gate driver is available. Protections and Diagnosis are not available. Min/max parameters are not guaranteed.
- Source-Drain ON Resistance (Reverse Drain-to-Source ON Resistance) with negative polarity  $V_{PWR}$ .

**Table 4. Static Electrical Characteristics (continued)**

Characteristics noted under conditions  $6.0\text{ V} \leq V_{PWR} \leq 27\text{ V}$ ,  $-40\text{ }^\circ\text{C} \leq T_A \leq 125\text{ }^\circ\text{C}$ , unless otherwise noted. Typical values noted reflect the approximate parameter mean at  $T_A = 25\text{ }^\circ\text{C}$  under nominal conditions, unless otherwise noted.

Characteristic	Symbol	Min	Typ	Max	Unit
----------------	--------	-----	-----	-----	------

**POWER OUTPUT (VPWR) (continued)**

Current Sense Voltage Clamp $I_{CSNS} = 15\text{ mA}$	$V_{CL(CSNS)}$	4.5	6.0	7.0	V
Current Sense Leakage <sup>(11)</sup> INHS = 1 with OUT opened of load or INHS = 0	$I_{LEAK(CSNS)}$	0	13	17	$\mu\text{A}$
Overtemperature Shutdown	$T_{SD}$	160	175	190	$^\circ\text{C}$
Overtemperature Shutdown Hysteresis <sup>(12)</sup>	$T_{SDHYS}$	5.0	–	20	$^\circ\text{C}$

**LOW SIDE GATE DRIVER (VPWR, VGLS, VOCLS)**

Low Side Gate Voltage $V_{PWR} = 6.0\text{ V}$ $V_{PWR} = 9.0\text{ V}$ $V_{PWR} = 13\text{ V}$ $V_{PWR} = 27\text{ V}$	$V_{GLS}$	5.0 8.0 12.0 12.0	5.4 8.4 12.4 12.4	6.0 9.0 13.0 13.0	V
Low Side Gate Sunked Current $V_{GLS} = 2.0\text{ V}$ , $V_{PWR} = 13\text{ V}$	$I_{GLSNEG}$	–	100	–	mA
Low Side Gate Sourced Current $V_{GLS} = 2.0\text{ V}$ , $V_{PWR} = 13\text{ V}$	$I_{GLSPOS}$	–	100	–	mA
Low Side Overload Detection Level versus Low Side Drain Voltage $V_{OCLS} - V_{DLS}$ , ( $V_{OCLS} \leq 4.0\text{ V}$ )	$V_{DS\_LS}$	-50	–	+50	mV

**CONTROL INTERFACE (CONF, INHS, INLS, EN, OCLS)**

Input Logic High-voltage (CONF, INHS, INLS)	$V_{IH}$	3.3	–	–	V
Input Logic Low-voltage (CONF, INHS, INLS)	$V_{IL}$	–	–	1.0	V
Input Logic Voltage Hysteresis (CONF, INHS, INLS)	$V_{INHYS}$	100	600	1200	mV
Input Logic Active Pull-down Current (INHS, INLS)	$I_{DWN}$	5.0	10	20	$\mu\text{A}$
Enable Pull-down Resistor (EN)	$R_{DWN}$	100	200	400	$\text{k}\Omega$
Enable Voltage Threshold (EN)	$V_{EN}$		2.5		V
Input Clamp Voltage (EN) $I_{EN} < 2.5\text{ mA}$	$V_{CLEN}$	7.0	–	14	V
Input Forward Voltage (EN)	$V_{F(EN)}$	-2.0	–	-0.3	V
Input Active Pull-up Current (OCLS)	$I_{OCLSp}$	50	100	200	$\mu\text{A}$
Input Active Pull-up Current (CONF)	$I_{CONF}$	5.0	10	20	$\mu\text{A}$

Notes

- This parameter is achieved by the design characterization by measuring a statistically relevant sample size across process variations but not tested in production.
- Parameter is guaranteed by process monitoring but is not production tested.



**Table 4. Static Electrical Characteristics (continued)**

Characteristics noted under conditions  $6.0\text{ V} \leq V_{PWR} \leq 27\text{ V}$ ,  $-40\text{ }^\circ\text{C} \leq T_A \leq 125\text{ }^\circ\text{C}$ , unless otherwise noted. Typical values noted reflect the approximate parameter mean at  $T_A = 25\text{ }^\circ\text{C}$  under nominal conditions, unless otherwise noted.

Characteristic	Symbol	Min	Typ	Max	Unit
<b>CONTROL INTERFACE (CONF, INHS, INLS, EN, OCLS) (continued)</b>					
$\overline{\text{FS}}$ Tri-state Capacitance <sup>(13)</sup>	$C_{\text{FS}}$	–	–	20	pF
$\overline{\text{FS}}$ Low-state Output Voltage $I_{\overline{\text{FS}}} = -1.6\text{ mA}$	$V_{\text{FSL}}$	–	0.2	0.4	V
Temperature Feedback $T_A = 25\text{ }^\circ\text{C}$ for $V_{\text{PWR}} = 14\text{ V}$	$V_{\text{TFEED}}$	3.35	3.45	3.55	V
Temperature Feedback Derating <sup>(13)</sup>	$DT_{\text{FEED}}$	-8.5	-8.9	-9.3	mV/°C

Notes

13. Parameter is guaranteed by process monitoring but is not production tested.

**DYNAMIC ELECTRICAL CHARACTERISTICS**

**Table 5. Dynamic Electrical Characteristics**

Characteristics noted under conditions  $6.0\text{ V} \leq V_{PWR} \leq 27\text{ V}$ ,  $-40\text{ }^\circ\text{C} \leq T_A \leq 125\text{ }^\circ\text{C}$ , unless otherwise noted. Typical values noted reflect the approximate parameter mean at  $T_A = 25\text{ }^\circ\text{C}$  under nominal conditions, unless otherwise noted.

Characteristic	Symbol	Min	Typ	Max	Unit
<b>CONTROL INTERFACE AND POWER OUTPUT TIMING (CBOOT, VPWR)</b>					
Charge Blanking Time (CBOOT) <sup>(15)</sup>	$t_{ON}$	10	25	50	$\mu\text{s}$
Output Rising Slew Rate $V_{PWR} = 13\text{ V}$ , from 10% to 90% of $V_{OUT}$ , SR Capacitor = 4.7 nF, $R_L = 5.0\ \Omega$	$SR_R$	8.0	16	35	$\text{V}/\mu\text{s}$
Output Falling Slew Rate $V_{PWR} = 13\text{ V}$ , from 90% to 10% of $V_{OUT}$ , SR Capacitor = 4.7 nF, $R_L = 5.0\ \Omega$	$SR_F$	8.0	16	35	$\text{V}/\mu\text{s}$
Output Turn-ON Delay Time <sup>(16)</sup> $V_{PWR} = 13\text{ V}$ , SR Capacitor = 4.7 nF	$t_{DLYON}$	200	400	700	ns
Output Turn-OFF Delay Time <sup>(17)</sup> $V_{PWR} = 13\text{ V}$ , SR Capacitor = 4.7 nF	$t_{DLYOFF}$	500	1000	1500	ns
Input Switching Frequency <sup>(14)</sup>	$f_{PWM}$	–	20	60	kHz
Output PWM ratio at 60 kHz <sup>(18)</sup>	$R_{PWM}$	5.0	–	95	%
Time to Reset Fault Diagnosis (overload on high side or external low side)	$t_{RSTDIAG}$	100	200	400	$\mu\text{s}$
Output Overcurrent Detection Time	$t_{OCH}$	1.0	10	20	$\mu\text{s}$

Notes

14. The 34981 fully operates down to DC. To reset a latched Fault the INHS pin must go low for the “Time to reset Fault Diagnosis” ( $t_{RSTDIAG}$ ).
15. Values for CBOOT=100 nF. Refer to [Sleep Mode on page 16](#). Parameter is guaranteed by design and not production tested.
16. Turn-ON delay time measured from rising edge of INHS that turns the output ON to  $V_{OUT} = 0.5\text{ V}$  with  $R_L = 5.0\ \Omega$  resistive load.
17. Turn-OFF delay time measured from falling edge of INHS that turns the output OFF to  $V_{OUT} = V_{PWR} - 0.5\text{ V}$  with  $R_L = 5.0\ \Omega$  resistive load.
18. The ratio is measured at  $V_{OUT} = 50\% V_{PWR}$  without SR capacitor. The device is capable of 100% duty cycle.

**TIMING DIAGRAMS**

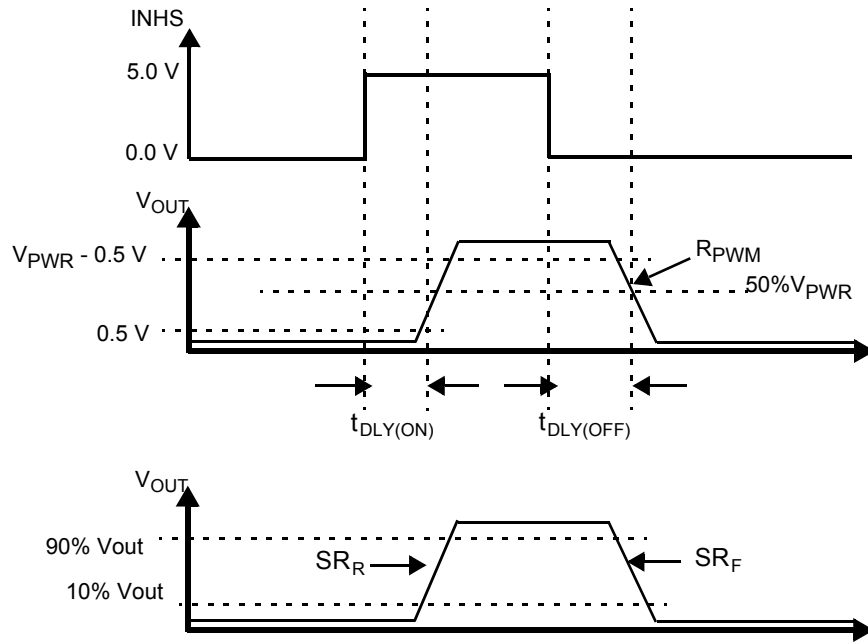

**Figure 4. Time Delays Functional Diagrams**

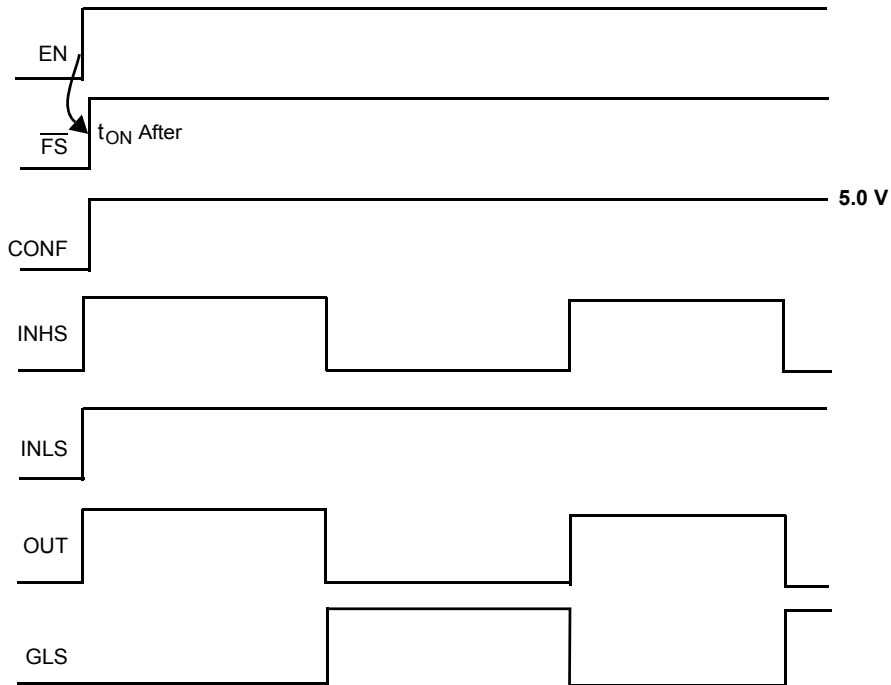

**Figure 5. Normal Mode, Cross-Conduction Management**

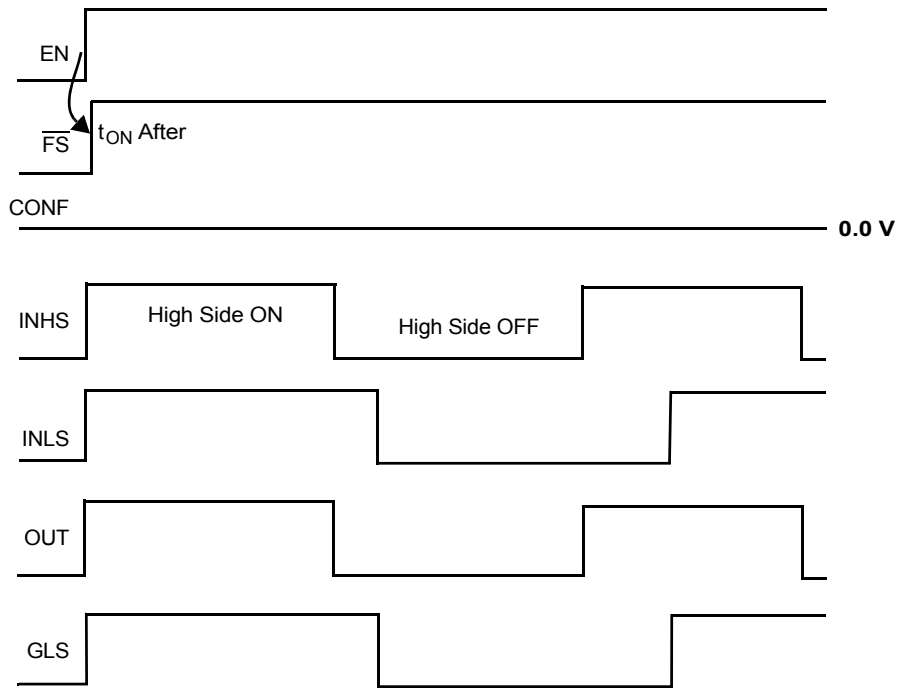

Figure 6. Normal Mode, Independent High Side and Low Side

**ELECTRICAL PERFORMANCE CURVES**

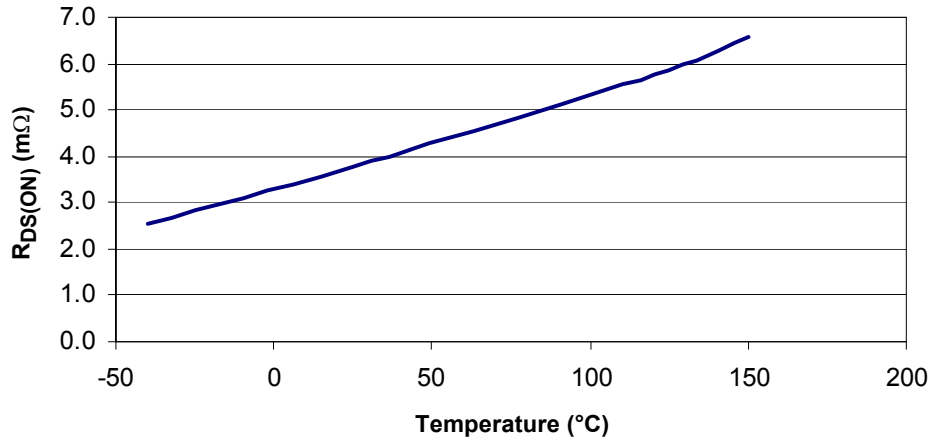

Figure 7. Typical  $R_{DS(ON)}$  vs. Temperature at  $V_{PWR} = 13\text{ V}$

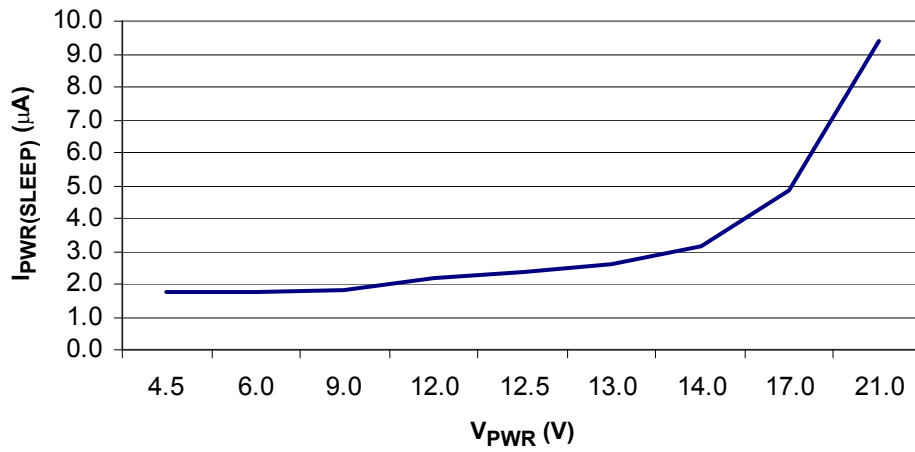

Figure 8. Typical Sleep-state Supply Current vs.  $V_{PWR}$  at  $150\text{ °C}$

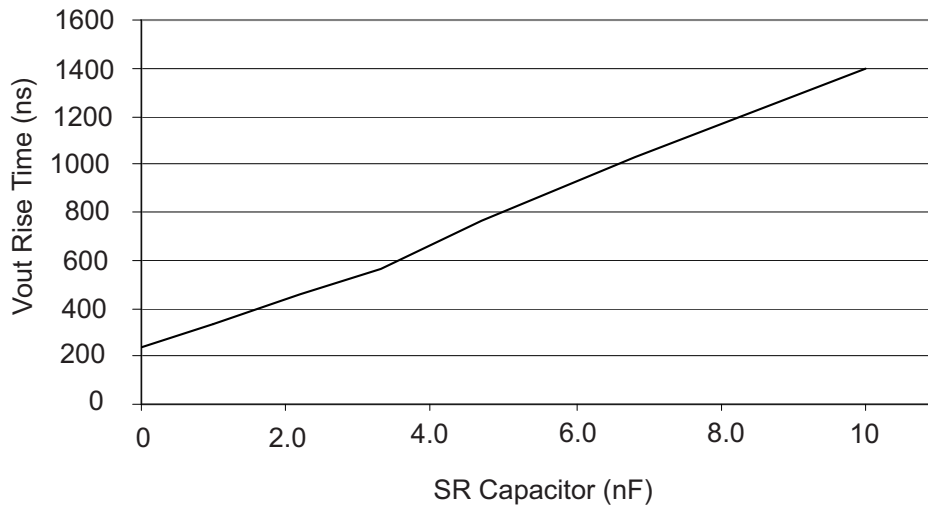

Figure 9.  $V_{OUT}$  Rise Time vs. SR Capacitor From 10% to 90% of  $V_{OUT}$  at  $25\text{ °C}$  and  $V_{PWR} = 13\text{ V}$

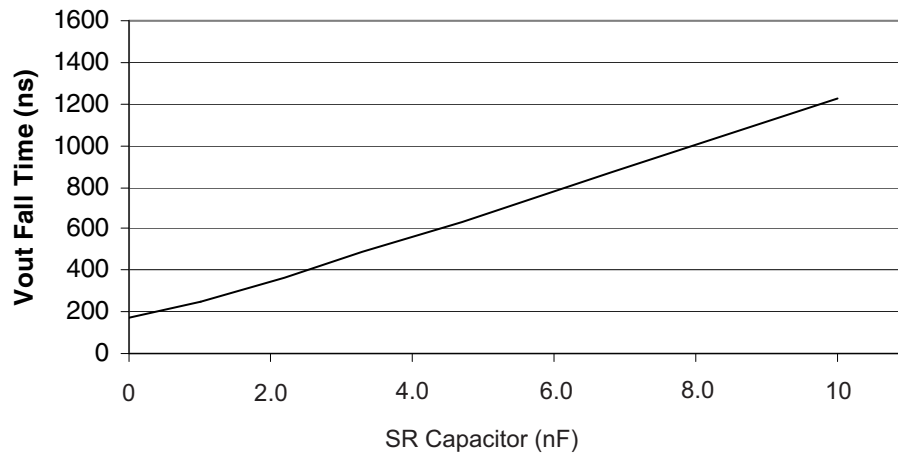

Figure 10.  $V_{OUT}$  Fall Time vs. SR Capacitor From 10% to 90% of  $V_{OUT}$  at 25 °C and  $V_{PWR} = 13$  V

## FUNCTIONAL DESCRIPTION

### INTRODUCTION

The 34981 is a high-frequency self-protected silicon  $4.0\text{ m}\Omega R_{DS(ON)}$  high side switch used to replace electromechanical relays, fuses, and discrete devices in power management applications. The 34981 can be controlled by pulse-width modulation (PWM) with a frequency up to 60 kHz. It is designed for harsh environments, and it includes self-recovery features.

The 34981 is suitable for loads with high inrush current, as well as motors and all types of resistive and inductive loads. A dedicated parallel input is available for an external low side control with protection features and cross-conduction management.

### FUNCTIONAL PIN DESCRIPTIONS

#### OUTPUT CURRENT MONITORING (CSNS)

This pin is used to output a current proportional to the high side OUT current and is used externally to generate a ground-referenced voltage for the microcontroller (MCU) to monitor OUT current.

#### TEMPERATURE FEEDBACK (TEMP)

This pin reports an analog value proportional to the temperature of the GND flag (pin 13). It is used by the MCU to monitor board temperature.

#### ENABLE [ACTIVE HIGH] (EN)

This is an input used to place the device in a low-current Sleep Mode. This pin has an active passive internal pull-down.

#### INPUT HIGH SIDE (INHS)

The input pin is used to directly control the OUT. This input has an active internal pull-down current source and requires CMOS logic levels.

#### FAULT STATUS ( $\overline{FS}$ )

This pin is an open drain-configured output requiring an external pull-up resistor to  $V_{DD}$  (5.0 V) for fault reporting. When a device fault condition is detected, this pin is active LOW.

#### INPUT LOW SIDE (INLS)

This input pin is used to directly control an external low side N-channel MOSFET and has an active internal pull-down current source and requires CMOS logic levels. It can be controlled independently of the INHS depending of CONF pin.

#### CONFIGURATION INPUT (CONF)

This input pin is used to manage the cross-conduction between the internal high side N-channel MOSFET and the external low side N-channel MOSFET. The pin has an active internal pull-up current source. When CONF is at 0 V, the

two MOSFETs are controlled independently. When CONF is at  $V_{DD}$  5.0 V, the two MOSFETs cannot be on at the same time.

#### LOW SIDE OVERLOAD (OCLS)

This pin sets the  $V_{DS}$  protection level of the external low side MOSFET. This pin has an active internal pull-up current source. It must be connected to an external resistor.

#### DRAIN LOW SIDE (DLS)

This pin is the drain of the external low side N-channel MOSFET. Its monitoring allows protection features: low side short protection and  $V_{PWR}$  short protection.

#### LOW SIDE GATE (GLS)

This pin is an output used to drive the gate of the external low side N-channel MOSFET.

#### SLEW RATE CONTROL (SR)

A capacitor connected between this pin and ground is used to control the output slew rate.

#### BOOTSTRAP CAPACITOR (CBOOT)

A capacitor connected between this pin and OUT is used to switch the OUT in PWM mode.

#### GROUND (GND)

This pin is the ground for the logic and analog circuitry of the device.

#### POSITIVE POWER SUPPLY (VPWR)

This pin connects to the positive power supply and is the source input of operational power for the device. The VPWR pin is a backside surface mount tab of the package.

#### OUTPUT (OUT)

Protected high side power output to the load. Output pins must be connected in parallel for operation.

## FUNCTIONAL DEVICE OPERATION

### OPERATIONAL MODES

The 34981 has 2 operating modes: Sleep and Normal depending on EN input.

#### SLEEP MODE

Sleep Mode is the state of the 34981 when the EN is logic [0]. In this mode, OUT, the gate driver for the external MOSFET, and all unused internal circuitry are off to minimize current draw.

#### NORMAL MODE

The 34981 goes to the Normal operating mode when the EN pin is logic [1]. The INHS and INLS commands are disabled  $t_{ON}$  after the EN transitions to logic [1] to enable the charge of the bootstrap capacitor.

**Table 6. Operating Modes**

Condition	CONF	INHS	INLS	OUT	GLS	$\overline{FS}$	EN	Comments
Sleep	x	x	x	x	x	H	L	Device is in Sleep Mode. The OUT and low side gate are OFF.
Normal	L	H	H	H	H	H	H	Normal mode. High side and low side are controlled independently. The high side and the low side are both on.
Normal	L	L	L	L	L	H	H	Normal mode. High side and low side are controlled independently. The high side and the low side are both off.
Normal	L	L	H	L	H	H	H	Normal mode. Half-bridge configuration. The high side is off and the low side is on.
Normal	L	H	L	H	L	H	H	Normal mode. Half-bridge configuration. The high side is on and the low side is off.
Normal	H	PWM	H	PWM	PWM_bar	H	H	Normal mode. Cross-conduction management is activated. Half-bridge configuration.

H = High level

L = Low level

x = Don't care

PWM\_bar = Opposite of pulse-width modulation signal.

### PROTECTION AND DIAGNOSTIC FEATURES

#### UNDERVOLTAGE

The 34981 incorporates undervoltage protection. In case of  $V_{PWR} < V_{PWR(UV)}$ , the OUT is switched OFF until the power supply rises to  $V_{PWR(UV)} + V_{PWR(UVHYS)}$ . The latched fault are reset below  $V_{PWR(UV)}$ . The FS output pin reports the undervoltage fault in real time.

#### OVERTEMPERATURE FAULT

The 34981 incorporates overtemperature detection and shutdown circuitry on OUT. Overtemperature detection also protects the low side gate driver (GLS pin). Overtemperature detection occurs when OUT is in the ON or OFF state and GLS is at high or low level.

For OUT, an overtemperature fault condition results in OUT turning OFF until the temperature falls below  $T_{SD}$ . This cycle continues indefinitely until the offending load is removed. [Figure 12](#) and [Figure 18](#) show an overtemperature on OUT.

An overtemperature fault on the low side gate drive results in OUT turning OFF and the GLS going to 0V until the

temperature falls below  $T_{SD}$ . This cycle continues until the offending load is removed. FS pin transition to logic [1] is disabled typically  $t_{ON}$  seconds after to enable the charge of the bootstrap capacitor.

Overtemperature faults force the TEMP pin to 0 V.

#### OVERCURRENT FAULT ON HIGH SIDE

The OUT pin has an overcurrent high-detection level called  $I_{OCH}$  for maximum device protection. If at any time the current reaches this level, OUT stays OFF and the CSNS pin goes to 0 V. The OUT pin is reset (and the fault is delatched) by a logic [0] at the INHS pin for at least  $t_{RST(DIAG)}$ . When INHS goes to 0 V, CSNS goes to 5.0 V.

In [Figure 15](#), the OUT pin is short-circuited to 0V. When the current reaches  $I_{OCH}$ , OUT is turned OFF within  $t_{OCH}$  owing to internal logic circuit.

#### OVERLOAD FAULT ON LOW SIDE

This fault detection is active when INLS is logic [1]. Low side overload protection does not measure the current



directly but rather its effects on the low side MOSFET. When  $V_{DLS} > V_{OCLS}$ , the GLS pin goes to 0 V and the OCLS internal current source is disconnected and OCLS goes to 0 V. The GLS pin and the OCLS pin are reset (and the fault is detached) by a logic [0] at the INLS pin for at least  $t_{RST(DIAG)}$ . [Figure 13](#) and [Figure 14](#) illustrate the behavior in case of overload on the low side gate driver.

When connected to an external resistor, the OCLS pin with its internal current source sets the  $V_{OCLS}$  level. By changing the external resistance, the protection level can be adjusted depending on low side characteristics. A 33 k $\Omega$  resistor gives a  $V_{DS}$  level of 3.3 V typical.

This protection circuitry measures the voltage between the drain of the low side (DLS pin) and the 34981 ground (GND pin). For this reason it is key the low side source, the 34981 ground and the external resistance ground connection, are connected together in order to prevent false error detection due to ground shifts.

The maximum OCLS voltage being 4.0 V, a resistor bridge on DLS must be used to detect a higher voltage across the low side.

## CONFIGURATION

The CONF pin manages the cross-conduction between the internal MOSFET and the external low side MOSFET. With the CONF pin at 0 V, the two MOSFETs can be independently controlled. A load can be placed between the high side and the low side.

With the CONF pin at 5.0 V, the two MOSFETs cannot be on at the same time. They are in half-bridge configuration as shown in the [34981 Simplified Application Diagram](#). If INHS and INLS are at 5.0 V at the same time, INHS has priority and OUT is at  $V_{PWR}$ . If INHS changes from 5.0 V to 0 V with INLS at 5.0 V, GLS goes to high state as soon as the  $V_{GS}$  of the internal MOSFET is lower than 2.0 V typically. A half-bridge application could consist in sending PWM signal to the INHS pin and 5.0 V to the INLS pin with the CONF pin at 5.0 V.

[Figure 20](#), illustrates the simplified application diagram in the [34981 Simplified Application Diagram](#) with a DC motor and external low side. The CONF and INLS pins are at 5.0 V. When INHS is at 5.0 V, current is flowing in the motor. When INHS goes to 0 V, the load current recirculates in the external low side.

## BOOTSTRAP SUPPLY

Bootstrap supply provides current to charge the bootstrap capacitor through the VPWR pin. A short time is required after the application of power to the device to charge the bootstrap capacitor. A typical value for this capacitor is 100 nF. An internal charge pump allows continuous MOSFET drive.

When the device is in the sleep mode, this bootstrap supply is off to minimize current consumption.

## HIGH SIDE GATE DRIVER

The high side gate driver switches the bootstrap capacitor voltage to the gate of the MOSFET. The driver circuit has a low-impedance drive to ensure the MOSFET remains OFF in the presence of fast falling dV/dt transients on the OUT pin.

This bootstrap capacitor connected between the power supply and the  $C_{BOOT}$  pin provides the high pulse current to drive the device. The voltage across this capacitor is limited to about 13 V typical.

An external capacitor connected between pins SR and GND is used to control the slew rate at the OUT pin. [Figure 9](#) and [Figure 10](#) give  $V_{OUT}$  rise and fall time versus different SR capacitors.

## LOW SIDE GATE DRIVER

The low side control circuitry is PWM capable. It can drive a standard MOSFET with an  $R_{DS(ON)}$  as low as 10.0 m $\Omega$  at a frequency up to 60 kHz. The  $V_{GS}$  is internally clamped at 12 V typically to protect the gate of the MOSFET. The GLS pin is protected against short by a local overtemperature sensor.

## THERMAL FEEDBACK

The 34981 has an analog feedback output (TEMP pin) provides a value in inverse proportion to the temperature of the GND flag (pin 13). The controlling microcontroller can "read" the temperature proportional voltage with its analog-to-digital converter (ADC). This can be used to provide real-time monitoring of the PC board temperature to optimize the motor speed and to protect the whole electronic system. TEMP pin value is  $V_{TFEED}$  with a negative temperature coefficient of  $DT_{FEED}$ .

## REVERSE SUPPLY

The 34981 survives the application of reverse supply voltage as low as -16 V. Under these conditions, the output's gate is enhanced to decrease device power dissipation. No additional passive components are required. The 34981 survives these conditions until the maximum junction rating is reached.

In the case of reverse supply in a half-bridge application, a direct current passes through the external freewheeling diode and the internal high side.

As [Figure 11](#) shows, it is essential to protect this power line. The proposed solution is an external N-channel low side with its gate tied to supply voltage through a resistor. A high side in the  $V_{PWR}$  line could be another solution.

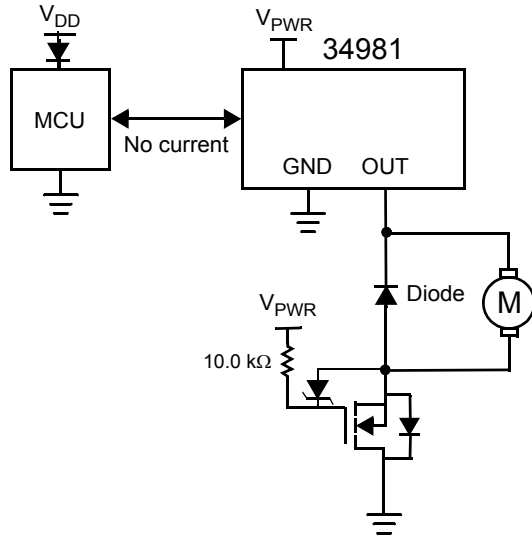

Figure 11. Reverse Supply Protection

### GROUND (GND) DISCONNECT PROTECTION

If the DC motor module ground is disconnected from load ground, the device protects itself and safely turns OFF the output regardless of the output state at the time of disconnection. A 10 k resistor needs to be added between the EN pin and the rest of the circuitry in order to ensure the device turns off in case of ground disconnect and to prevent exceeding this pin's maximum ratings.

### FAULT REPORTING

This 34981 indicates the faults below as they occur by driving the  $\overline{FS}$  pin to logic [0]:

- Overtemperature fault
- Overcurrent fault on OUT
- Overload fault on the external low side MOSFET

The  $\overline{FS}$  pin returns to logic [1] when the over temperature fault condition is removed. The two other faults are latched.

**Table 7. Functional Truth Table in Fault Mode**

Conditions	CONF	INHS	INLS	OUT	GLS	$\overline{FS}$	EN	TEMP	CSNS	OCLS	Comments
Overtemperature on OUT	x	x	x	L	H	L	H	L	x	x	The 34981 is currently in Fault mode. The OUT is OFF. TEMP at 0V indicates this fault. Once the fault is removed 34981 recovers its normal mode.
Overtemperature on GLS	x	x	x	L	L	L	H	L	x	x	The 34981 is currently in Fault mode. The OUT is OFF and GLS is at 0V. TEMP at 0V indicates this fault. Once the fault is removed 34981 recovers its Normal Mode.
Overcurrent on OUT	x	H	L	L	x	L	H	x	L	x	The 34981 is currently in Fault mode. The OUT is OFF. It is reset by a logic [0] at INHS for at least $t_{RST(DIAG)}$ . When INHS goes to 0 V, CSNS goes to 5.0 V.
Overload on External Low Side MOSFET	L	L	H	x	L	L	H	x	x	L	The 34981 is currently in Fault mode. GLS is at 0 V and OCLS internal current source is off. The external resistance connected between OCLS and GND pin pulls OCLS pin to 0 V. The fault is reset by a logic [0] at INLS for at least $t_{RST(DIAG)}$ .

H = High level  
 L = Low level  
 x = Don't care

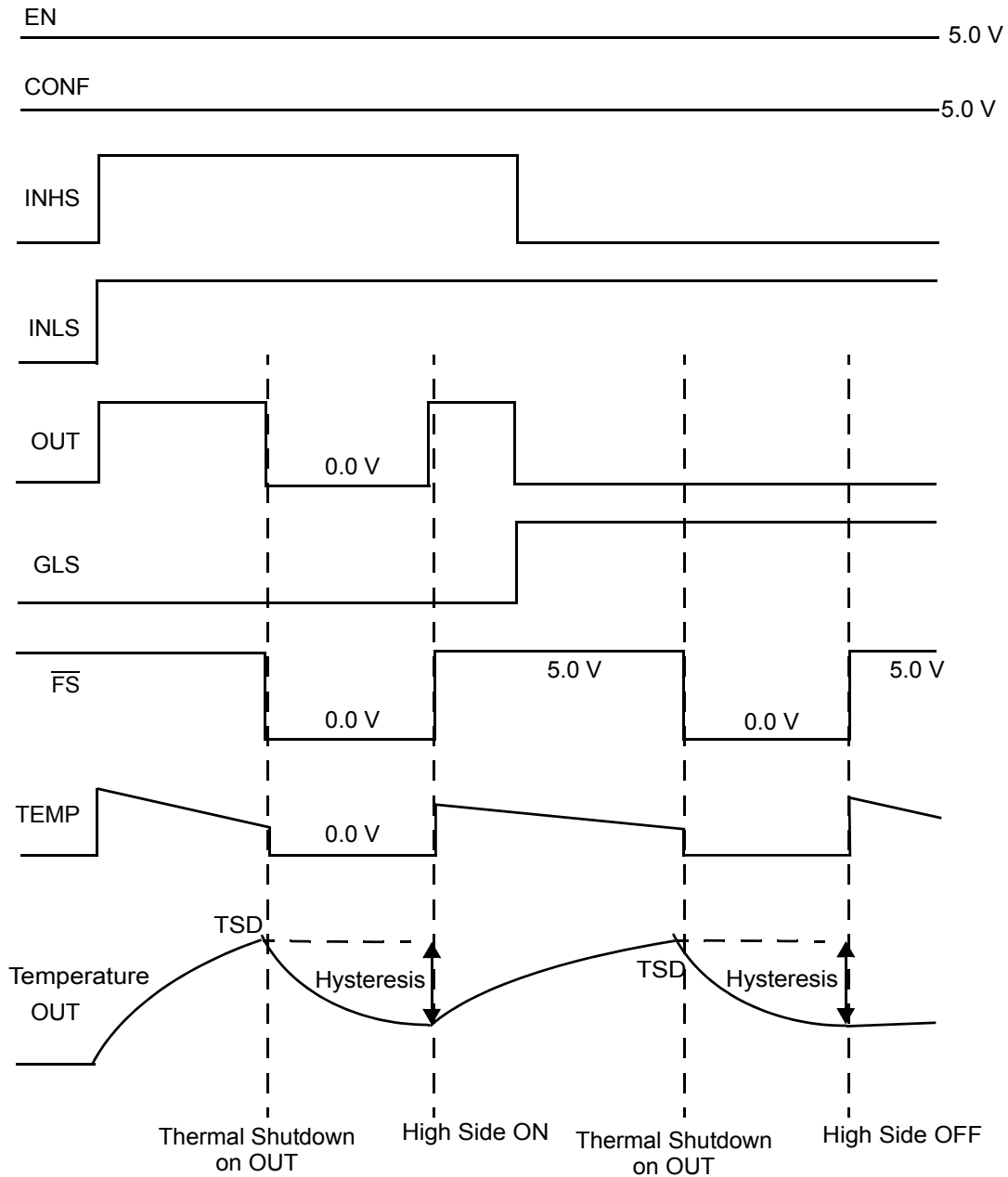
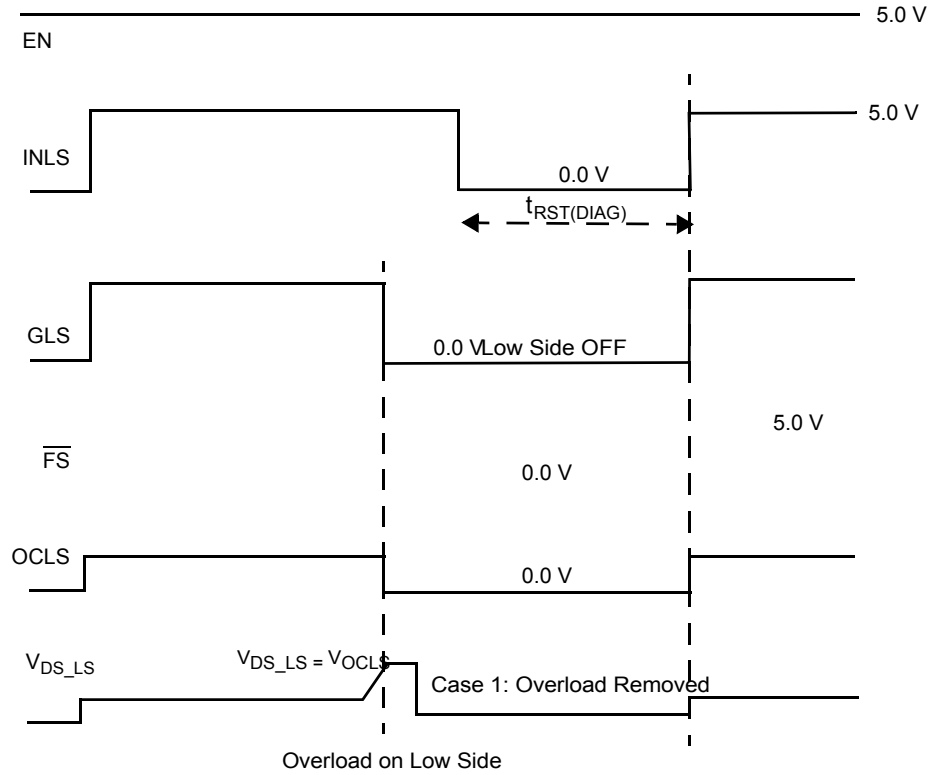
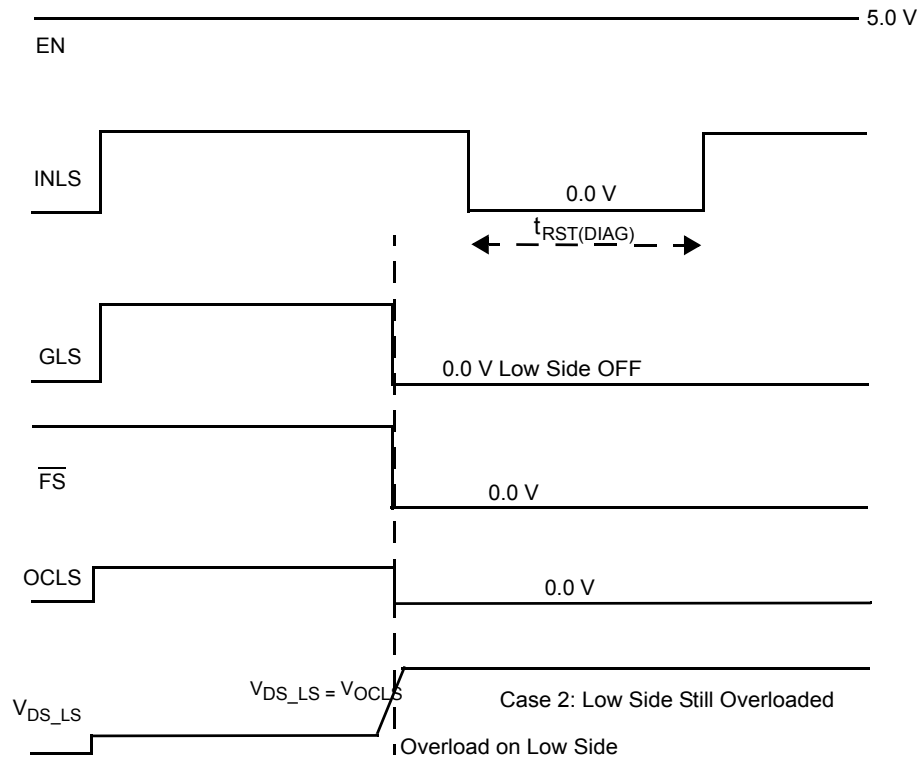

Figure 12. Overtemperature on Output



**Figure 13. Overload on Low Side Gate Drive, Case 1**



**Figure 14. Overload on Low Side Gate Drive, Case 2**

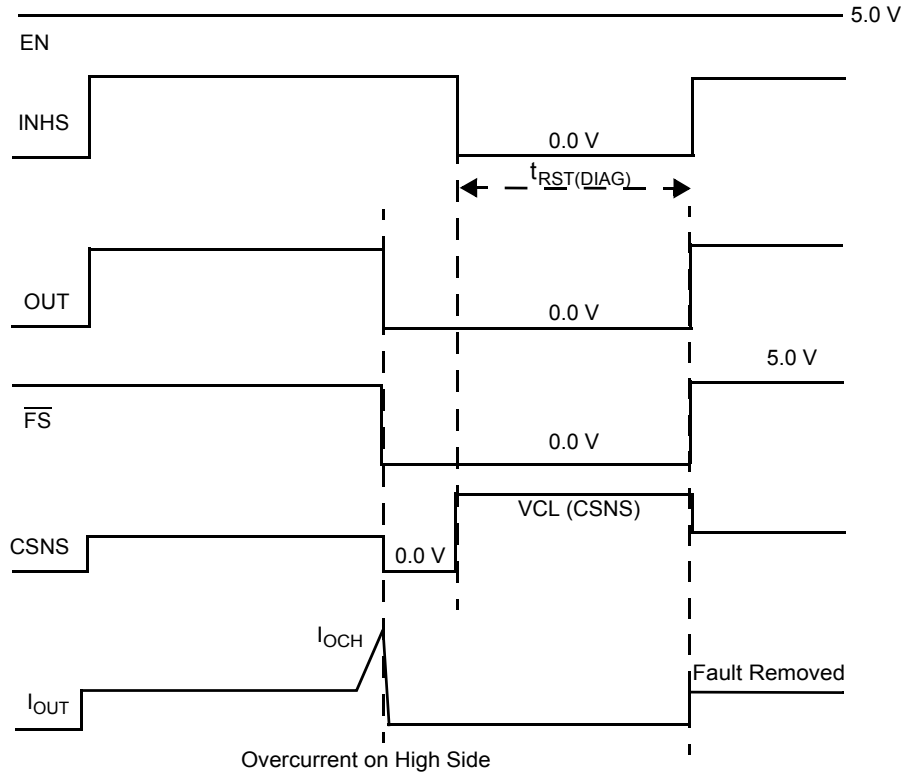

Figure 15. Overcurrent on Output

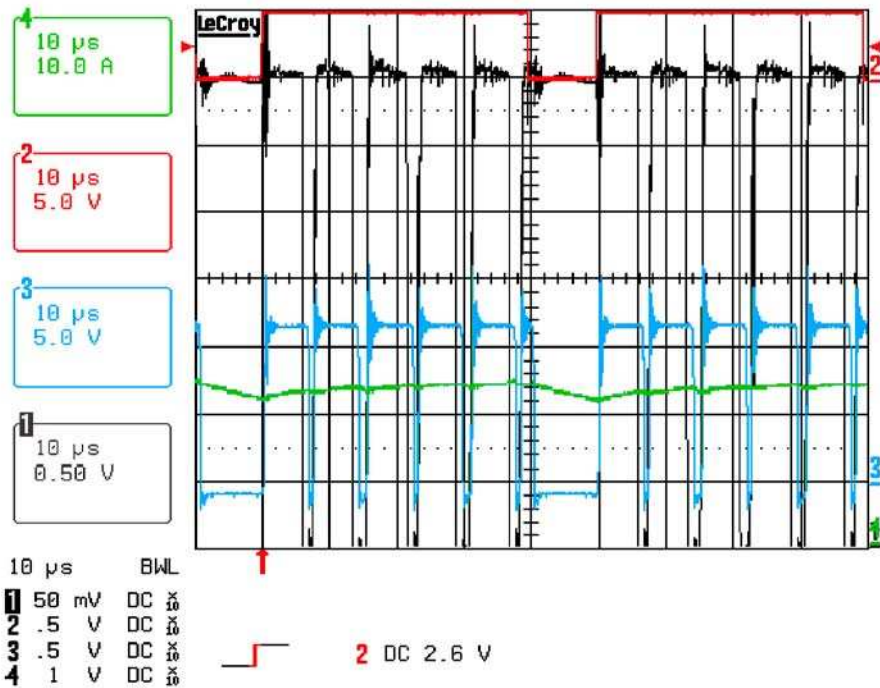

Figure 16. High Side Overcurrent

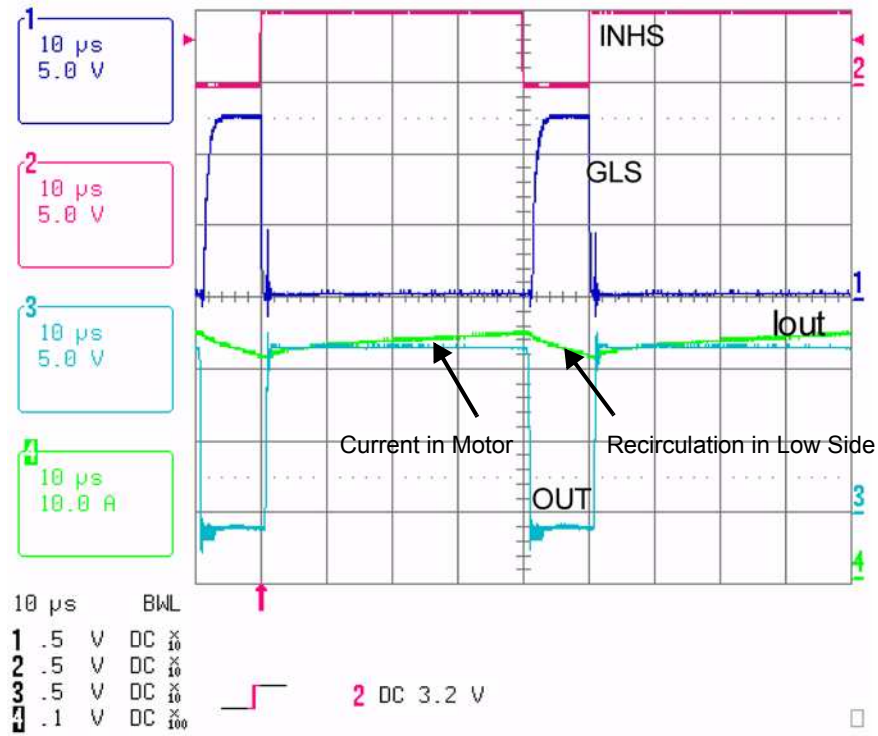

Figure 17. Cross-Conduction with Low Side

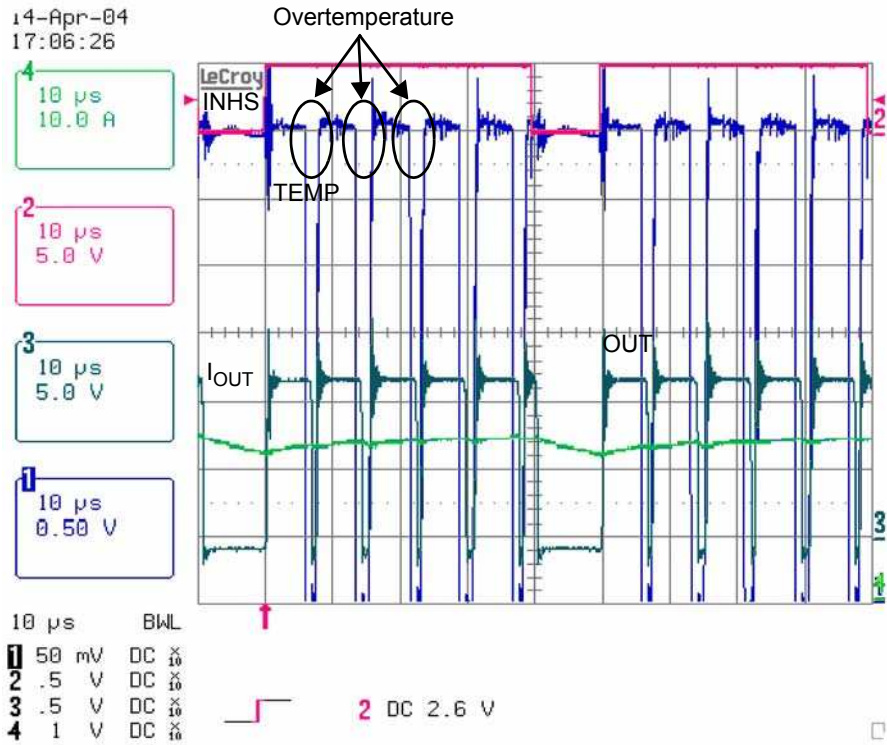

Figure 18. Overtemperature on OUT

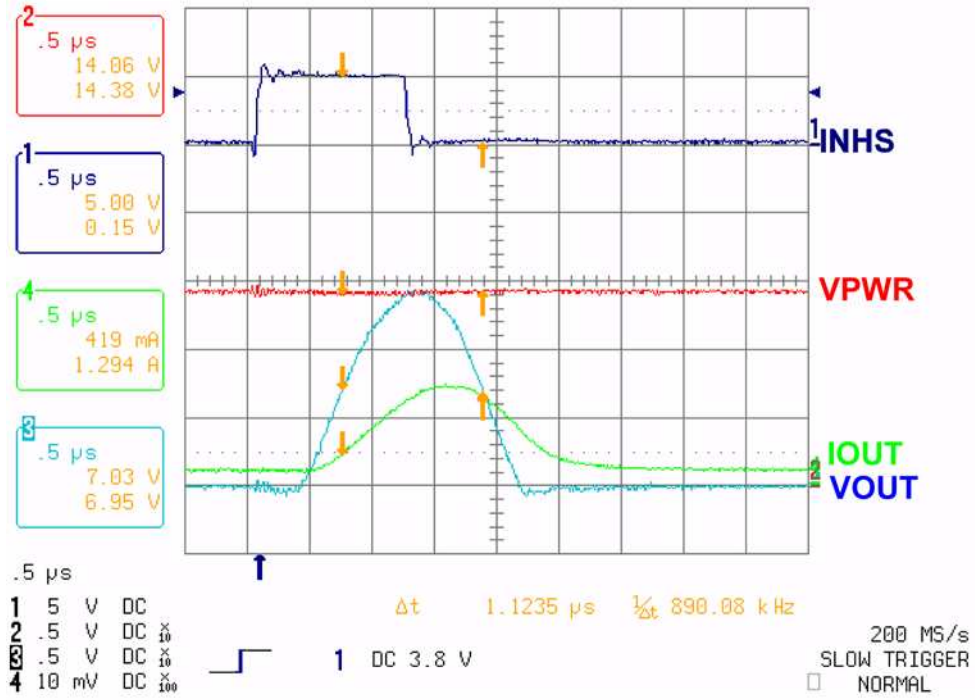

Figure 19. Maximum Operating Frequency for SR Capacitor of 4.7 nF



## TYPICAL APPLICATIONS

## INTRODUCTION

Figure 20 shows a typical application for the 34981. A brush DC motor is connected to the output. A low side gate driver is used for the freewheeling phase. Typical values for external capacitors and resistors are given.

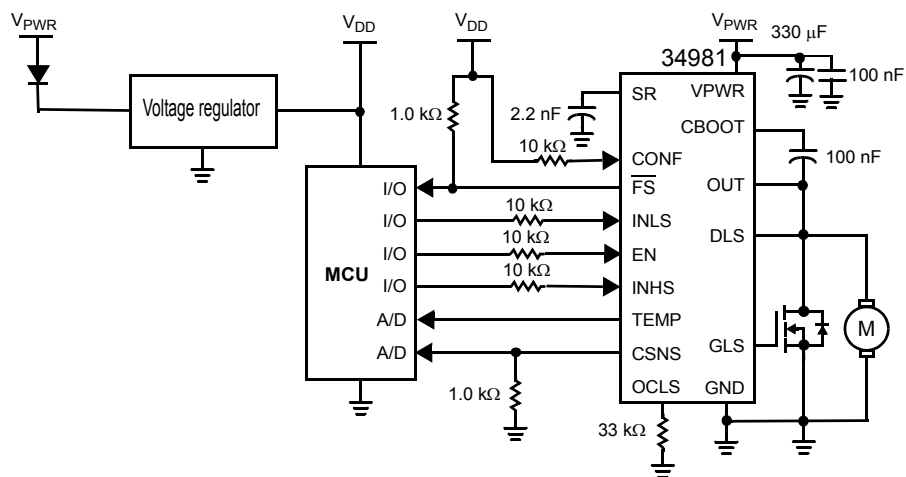

Figure 20. 34981 Typical Application Diagram

## EMC AND EMI RECOMMENDATIONS

## INTRODUCTION

This section relates the EMC capability for 34981, high frequency high-current high side switch. This device is a self-protected silicon switch used to replace electromechanical relays, fuses, and discrete circuits in power management applications.

This section presents the key features of the device and its targeted applications. The standard to measure conducted and radiated emissions is provided. Concrete measurements on the 34981 and improvements to reduce electromagnetic emission are described.

## DEVICE FEATURES

This 34981 is a 4.0 mΩ self-protected, high side switch digitally controlled from a microcontroller (MCU) with extended diagnostics, able to drive DC motors up to 60 kHz.

A bootstrap architecture has been used to provide fast transient gate voltage in order to reach 4.0 mΩ  $R_{DS(ON)}$  maximum at room temperature. In parallel, a charge pump is implemented to offer continuous on-state capability. This dual current supply of the high side MOSFET allows a duty cycle from 5% to 100%. An external capacitor connected between pins SR and GND is used to control the slew rate at

the output and, therefore, reduce electromagnetic perturbations.

In standard configuration, the motor current recirculation is handled by an external freewheeling diode. To reduce global power dissipation, the freewheeling diode can be replaced by an external discrete MOSFET in low side configuration. The IC integrates a gate driver, which controls and protects this external MOSFET in the event of a short-circuit to supply. The product manages the cross conduction between the internal high side and the external low side when used in a half-bridge configuration. The two MOSFETs can be controlled independently when the CONF pin is at 0 V. To eliminate fuses, the device is self-protected from severe short-circuits (100 A typical) with an innovative overcurrent strategy.

The 34981 has a current feedback for real-time monitoring of the load current through an MCU analog/digital converter to facilitate closed-loop operation for motor speed control.

The 34981 has an analog thermal feedback used by the MCU to monitor PC board temperature to optimize the motor control and to protect the entire electronic system. Therefore, an overtemperature shutdown feature protects the IC against high overload condition.

Figure 21 illustrates the typical application diagram.

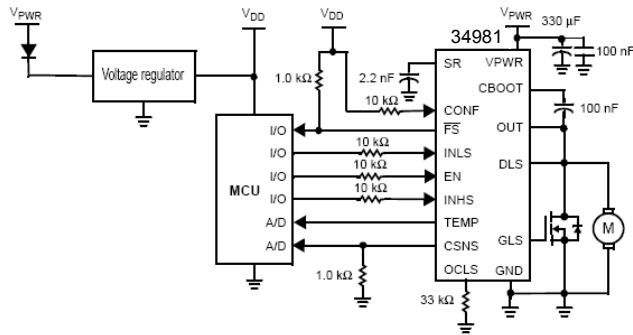

Figure 21. Typical Application Diagram

### APPLICATION

Engine cooling, air conditioning, and fuel pump are the targeted applications for the 34981. Conventional solutions are designed with discrete components are not optimized in terms of component board size, protection, and diagnostics. The 34981 is the right candidate to develop lighter and more compact units.

DC motor speed adjustment allows optimization of energy consumption by reducing supply voltage, hence the mean voltage applied to the motor. The commonly used control technique is pulse wide modulation (PWM) where the average voltage is proportional to the duty cycle. Most applications require a PWM frequency of at least 20 kHz to avoid audible noise. Figure 22 illustrates typical waveforms when switching the 34981 at 20 kHz with a duty cycle of 80%. The output voltage (OUT) and current in the motor ( $I_{MOTOR}$ ) waveforms are represented.

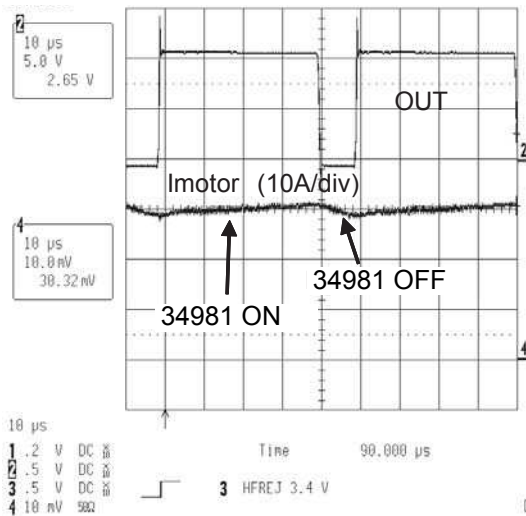

Figure 22. Current and Voltage waveforms

### HOW TO MEASURE ELECTROMAGNETIC EMISSION ACCORDING TO THE CISPR25

One EMC standard standard is the CISPR25, edited by the International Electrotechnical Commission. This standard describes the measurement method to measure both conducted and radiated emission.

### CONDUCTED EMISSION MEASUREMENT

Conducted emission is the emission produced by the device on the power supply cable. The test bench is described by CISPR25 (see Figure 23).

The Line Impedance Stabilization Network (LISN), also called artificial network (AN), in a given frequency range (150 kHz to 108 MHz), provides a specified load impedance for the measurement of disturbance voltages and isolates the equipment under test (EUT) from the supply in that frequency range.

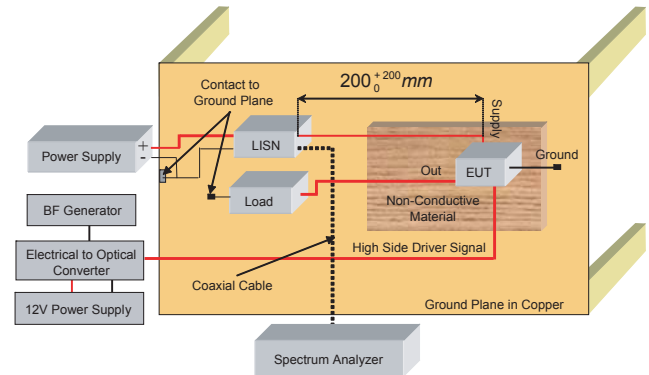

Figure 23. Test Bench for Conducted Emission

The EUT must operate under typical loading and other conditions just as it must in the vehicle so maximum emission state occurs. These operating conditions must be clearly defined in the test plan to ensure both supplier and customer are performing identical tests.

For the testing described in this application note, the out pin of the 34981 was connected to an inductive load ( $0.47 \Omega + 1.0 \mu\text{H}$ ) switching at 20 kHz with a duty cycle of 80%. The output current was 17 A continuous.

The ground return of the EUT to the chassis must be as short as possible. The power supply is 13.5 V.

### RADIATED EMISSION MEASUREMENT

The radiated emission measurement consists of measuring the electromagnetic radiation produced by the equipment under test. CISPR 25 gives the schematic test bench described in Figure .

To measure radiated emission over all frequency ranges, several antenna types must be used:

- 0.15 MHz to 30 MHz: 1.0 m vertical monopole in vertical polarization.
- 30 MHz to 200 MHz: a biconical antenna used in vertical and horizontal polarization.
- 200 MHz to 1,000 MHz: a log-periodic antenna used in vertical and horizontal polarization.

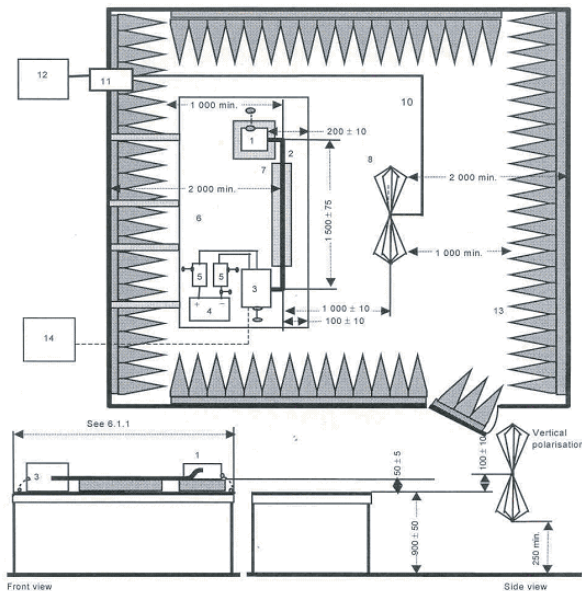

**Key**

- |   |  |
|---|--|
| 1 EUT (grounded locally if required in test plan)             | 8 Biconical antenna                                  |
| 2 Test harness  | — —  |
| 3 Load simulator (placement and ground connection)            | 10 High quality double-shielded coaxial cable (50 Ω) |
| 4 Power supply (location optional)                            | 11 Bulkhead connector                                |
| 5 Artificial Network (AN)                                     | 12 Measuring instrument                              |
| 6 Ground plane (bonded to shielded enclosure)                 | 13 RF absorber material                              |
| 7 Low relative permittivity support ( $\epsilon_r \leq 1.4$ ) | 14 Stimulation and monitoring system                 |

**Figure 24. Test Bench for Radiated Emission**

**EMC RESULTS AND IMPROVEMENTS**

The 34981 OUT is connected to an inductive load (0.47 Ω + 1.0mH) switching at 20 kHz with duty = 80%. The current in the load was 17 A continuous.

**BOARD SETUP**

The initial configuration of our 34981 board is represented in [Figure 25](#).

No SR capacitor is used. Therefore, the obtained switching times are the maximum values. A capacitor of 1000 μF is connected between VPWR and GND.

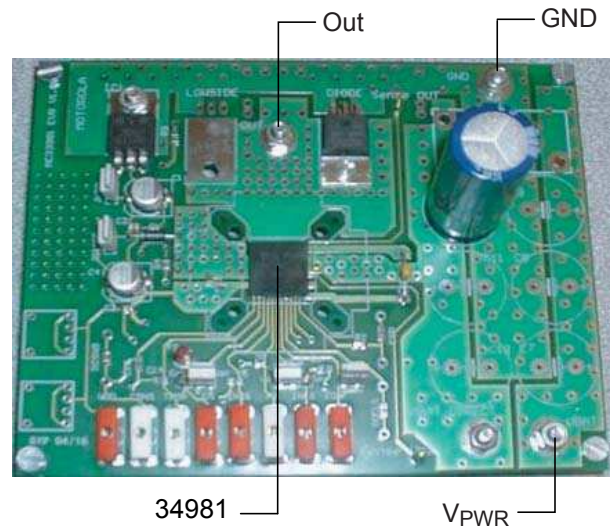
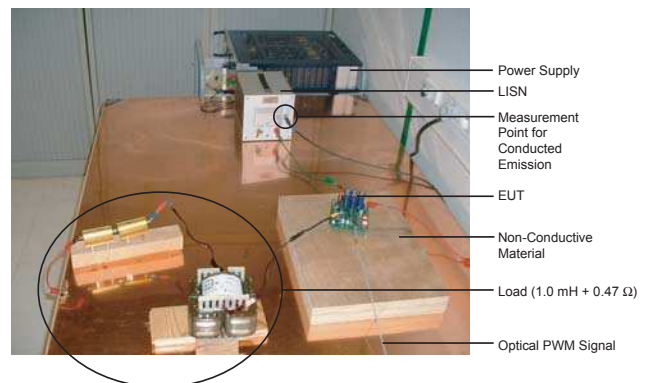

**Figure 25. 34981 Initial Configuration**

**CONDUCTED MEASUREMENTS**

**TEST SETUP**

To perform a conducted emission measurement in accordance with the CISPR 25 standard, the test bench in [Figure 26](#) was developed.



**Figure 26. Conducted Emission Test Setup**

## EFFECTS OF SOME PARAMETERS

The conducted emissions level rise with the duty cycle. When the duty increases the  $di/dt$  on the VPWR line is higher. The device has to deliver more current and provide more energy. [Figure 27](#) describes the effect of duty cycle increase on the  $V_{PWR}$  current waveform. The conducted emission level rises with the output frequency. This is due to the increasing number of commutations.



Figure 27. VPWR Current

## HOW TO REDUCE ELECTROMAGNETIC EMISSION

By adjusting the slew rate of the device during turn ON and turn OFF with SR capacitor, the electromagnetic emissions can be reduced.

Conductive emission tests were performed (taking care of the board filtering and routing that have a big impact on EMC performances).

An optimized solution was found by adding the following external components to the initial board:

- PI filter on the  $V_{PWR}$ :  $2 \times 3 \mu\text{F}$  and  $3.5 \mu\text{H}$
- RC IN filter between  $V_{PWR}$  and GND: a  $2.0 \Omega$  resistor in series with a  $100 \text{ nF}$  capacitor
- RC Out filter between OUT and GND: a  $4.7 \Omega$  resistor in series with a  $100 \text{ nF}$  capacitor
- Capacitor C1 of  $10 \text{ nF}$  between  $V_{PWR}$  and GND
- Capacitor C2 of  $10 \text{ nF}$  between OUT and GND
- Capacitor C3 of  $10 \text{ nF}$  between OUT and  $V_{PWR}$
- Capacitor SR of  $3.3 \text{ nF}$

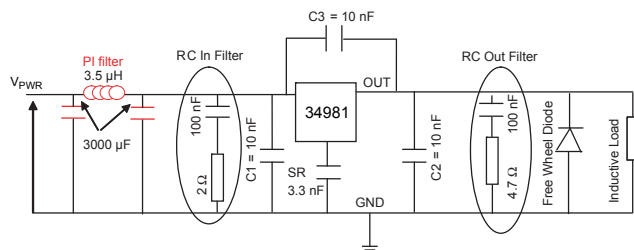

Figure 28. 34981 with Filter

The EMC enhanced board with adapted value filter is represented in [Figure 29](#).

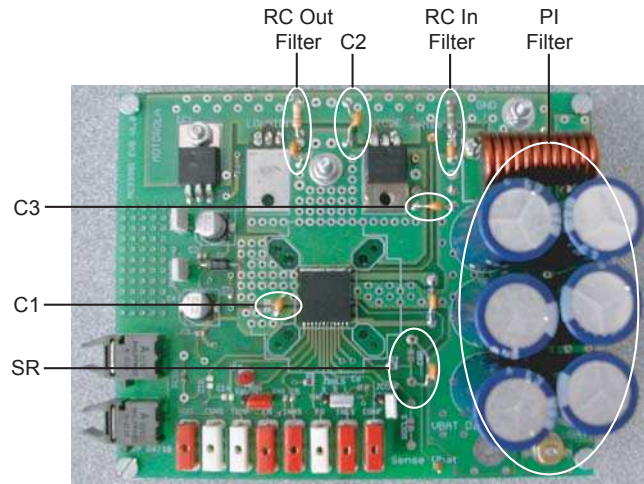

Figure 29. Enhanced Board

The chart in [Figure 30](#) shows the spectrum of the enhanced board and the initial board. The improvement is appreciatively  $15 \text{ dB}$  to  $20 \text{ dB}$  in the all frequency range. The enhanced board is now in accordance with the Class 3 limits of the CISPR25 standard for conducted emission.

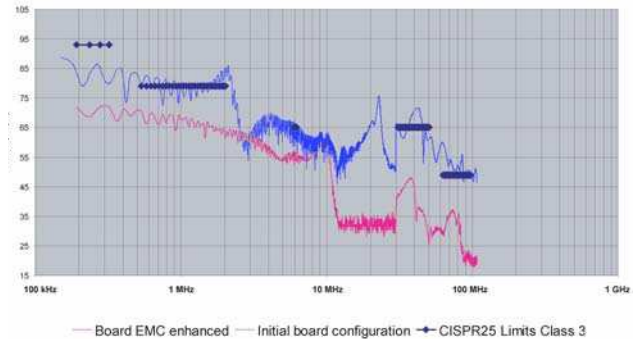
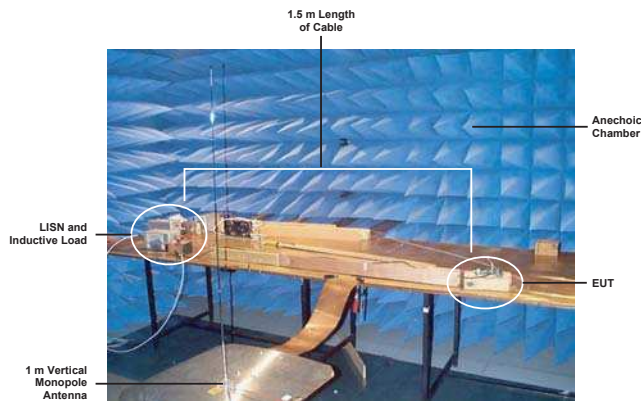

Figure 30. Conducted Emission Spectrum for 34981

## RADIATED MEASUREMENTS

This test was performed in order to evaluate the characteristic of the device relating to radiated emission. Measurements have been done in accordance with the CISPR 25 standard as shown in [Figure 31](#). The tested board was the EMC enhanced board.





**Figure 31. Radiated Emission Test Set-up**

The results of these measurements are represented in [Figure 32](#). The enhanced board is in accordance with the Class 3 limits of the CISPR25 standard for radiated emission.

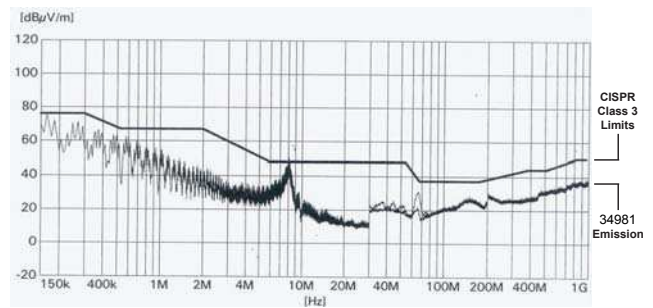

**Figure 32. Radiated Emission Spectrum for 34981**

## CONCLUSION

This document explains how to measure conducted and radiated emission in accordance with the CISPR25 standard. Measurements were performed on the 34981 in real application conditions, when driving an inductive load. An optimized filtering solution was put in place to have the tested system in accordance with the Class 3 limits. The same method can be used with other PC boards.

## POWER DISSIPATION

### INTRODUCTION

This section relates to the power dissipation capability for 34981, high frequency high-current high side switch. This device is a self-protected silicon switch used to replace electromechanical relays, fuses, and discrete circuits in power management applications.

This section presents the key features of the device and its targeted applications. The theoretical calculations for power dissipation and die junction temperatures are determined in this document for inductive loads. A concrete example with DC motor driven by the 34981 is analyzed in [DC Motor 200W](#).

### DEVICE FEATURES

This 34981 is a 4.0 mΩ self-protected, high side switch digitally controlled from a microcontroller (MCU) with extended diagnostics, able to drive DC motors up to 60 kHz.

A bootstrap architecture has been used to provide fast transient gate voltage in order to reach 4.0 mΩ  $R_{DS(ON)}$  maximum at room temperature. In parallel, a charge pump is implemented to offer continuous on-state capability. This dual current supply of the high side MOSFET allows a duty cycle from 5% to 100%. An external capacitor connected between pins SR and GND is used to control the slew rate at the output and, therefore, reduce electromagnetic perturbations.

In standard configuration, the motor current recirculation is handled by an external freewheeling diode. To reduce global power dissipation, the freewheeling diode can be replaced by an external discrete MOSFET in low side configuration. The IC integrates a gate driver which controls and protects this external MOSFET in the event of a short-circuit to supply.

The product manages the cross conduction between the internal high side and the external low side when used in a half-bridge configuration. The two MOSFETs can be controlled independently when the CONF pin is at 0 V. To eliminates fuses, the device is self-protected from severe short-circuits (100 A typical) with an innovative overcurrent strategy.

The 34981 has a current feedback for real-time monitoring of the load current through an MCU analog/digital converter to facilitate closed-loop operation for motor speed control.

The 34981 has an analog thermal feedback used by the MCU to monitor PC board temperature to optimize the motor control and to protect the entire electronic system. Therefore, an overtemperature shutdown feature protects the IC against high overload condition.

[Figure 33](#) illustrates the typical application diagram.

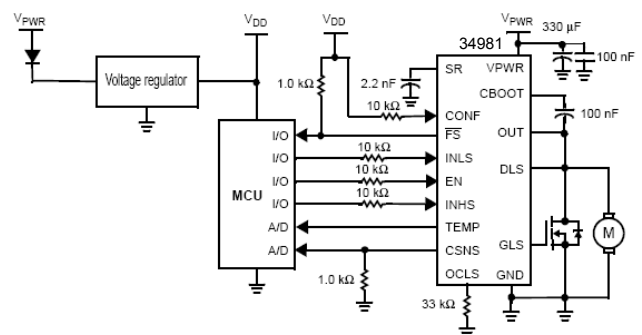

**Figure 33. Typical Application Diagram**

## APPLICATION

Engine cooling, air conditioning, and fuel pump are the targeted applications for the 34981. Conventional solutions are designed with discrete components are not optimized in terms of component board size, protection, and diagnostics. The 34981 is the right candidate to develop lighter and more compact units.

The adjustment of the DC motor speed allows optimizing of energy consumption. It is realized by chopping the supply voltage, hence the mean voltage, applied to the motor. The commonly used control technique is pulse wide modulation (PWM) where the average voltage is proportional to the duty cycle. Most applications require a PWM frequency of at least 20 kHz to avoid audible noise. [Figure 34](#) illustrates typical waveforms when switching the 34981 at 20 kHz with a duty cycle of 80%. The output voltage (OUT) and current in the motor ( $I_{MOTOR}$ ) waveforms are represented.

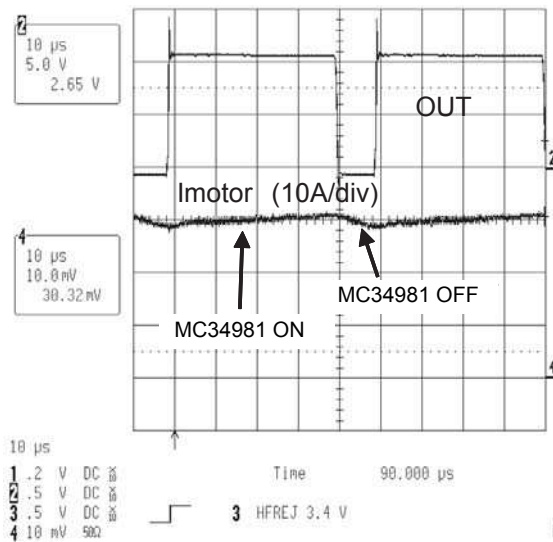

Figure 34. Current and Voltage waveforms

## POWER DISSIPATION

The 34981 power dissipation is the sum of two kinds of losses:

- On-State losses when device is fully ON,
- Switching losses when the device switches ON and OFF.

The following analysis assumes an inductive load and assumes the current is constant in the load.

The case being considered in this paper is inductive load and the hypothesis is the current is constant in the load.

## ON-STATE LOSSES

The mean on-state loss periods in the 34981 can be calculated as follows:

$$P_{on\_state} = a \cdot R_{DS(ON)} \cdot I_{OUT}^2$$

where 'a' is the duty cycle.

The critical parameter is the on resistance ( $R_{DS(ON)}$ ) increases with temperature. The 34981 has a maximum  $R_{DS(ON)}$  at 25 °C of 4.0 mΩ and its deviation with temperature is only 1.7 as shown in [Figure 35](#).

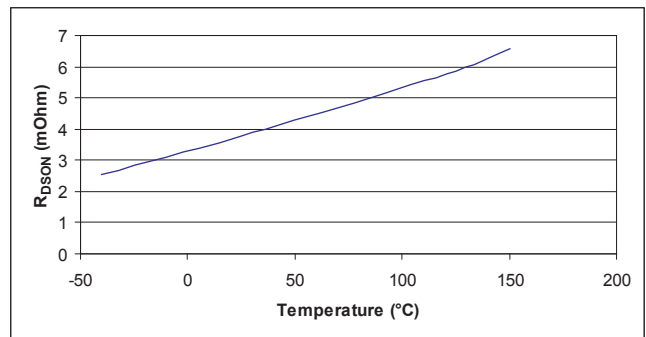

Figure 35.  $R_{DS(ON)}$  vs. Temperature

## SWITCHING LOSSES

The mean switching losses in the 34981 can be calculated as follows:

$$P_{switching} = (t_{ON} \cdot F_{REQ} \cdot V_{PWR} \cdot I_{OUT}) / 2 + (t_{OFF} \cdot F_{REQ} \cdot V_{PWR} \cdot I_{OUT}) / 2$$

where  $t_{ON}/t_{OFF}$  is the turn on/off time.

The switching time is a critical parameter. The 34981 provides adjustable slew rates through an external capacitor (SR), which slow down the rise and fall times to reduce the electromagnetic emissions. However, this adjustment has an impact on power dissipation. [Figure 36](#) gives the positive ( $SR_R$ ) and negative ( $SR_F$ ) slew rate versus different values of SR. This is illustrated in [Figure 37](#).

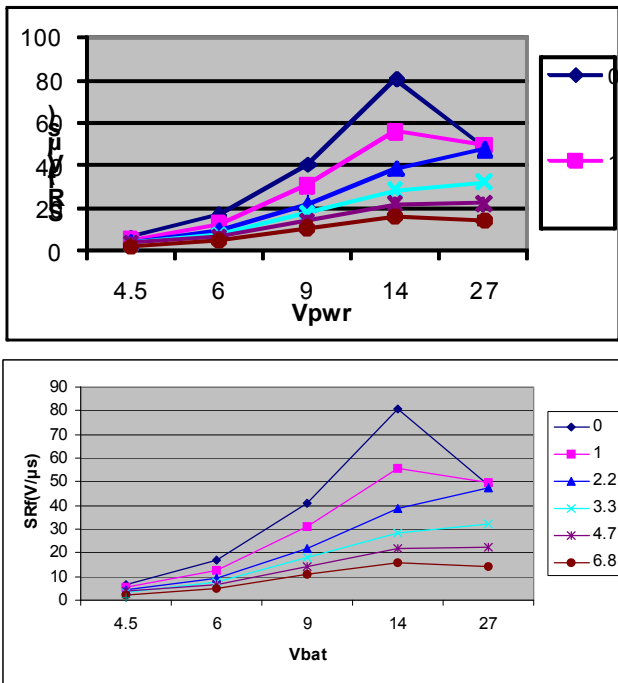

Figure 36. Positive and Negative Slew Rate vs. SR Capacitor

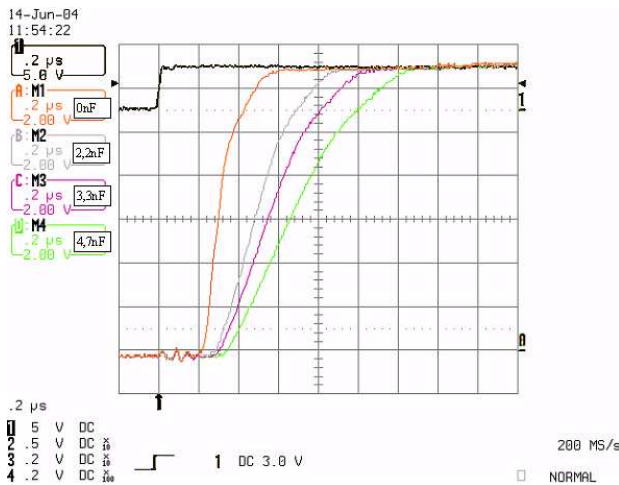

Figure 37. OUT switching vs. SR Capacitor

### JUNCTION TEMPERATURE

The junction temperature of the 34981 can be calculated knowing the power dissipation and the thermal characteristics of the PC board with this formula:

$$T_J = T_A + (P_{on\_state} + P_{switching}) \cdot R_{THJA}$$

where  $T_J$  is the junction temperature,  $T_A$  the ambient temperature, and  $R_{THJA}$  the thermal impedance junction to ambient.

### RECIRCULATION PHASE

In standard configuration, the motor current recirculation is handled by an external freewheeling diode. With the 34981, the freewheeling diode can be replaced by an external low-side discrete MOSFET.

The power dissipation during the recirculation phase is calculated as follows for the diode and the low-side MOSFET respectively:

$$P_{diode} = (1-a) \cdot V_F \cdot I_{OUT}$$

where 'a' is the duty cycle

$$P_{mosfet\_ls} = (1-a) \cdot R_{DS(ON)\_ls} \cdot I_{OUT}^2$$

where  $R_{DS(ON)\_ls}$  is the on resistance of the low side.

### APPLICATIONS EXAMPLES

#### EXCEL TOOL

An excel tool has been created with all the above formulas to calculate the dissipated power and the junction temperature knowing the application conditions. An example of the interface is given in Figure 38. The parameters to enter concern the load, the high side device, the recirculation, and the board. They are  $V_{PWR}$ , DC current in the load ( $I_{max}$  for 100% of duty cycle), PWM frequency, 34981  $R_{DS(ON)}$  at 150 °C, SR capacitor, low side  $R_{DS(ON)}$  at 150 °C, ambient temperature, and thermal impedance.

INPUTS		
Load	$V_{pwr}$	12 V
	$I_{max}$	20 A
	Frequency	20 KHz
High Side Device (HS)	$R_{DS(ON)}$ @150°C	6.8 mOhm
	SR Capacitor	0 nF
Recirculation	Low Side Characteristics	
	$R_{DS(ON)}$ @150°C	20 mOhm
Board	$R_{thja}$	15°C/W
	$T_{ambient}$	85°C

Figure 38. Excel Tool

The calculations are done with the maximum  $R_{DS(ON)}$  for the 34981 and the low side. The current is also considered constant in the load. The model taken for the  $V_F$  of the diode is  $(0.4 + 0.01 \cdot I_{OUT})$  Volts.

The listed conditions in Figure 38 are the ones chosen for the entire document.

### DC MOTOR 200W

A concrete example is the 34981. A 200 W DC motor, a frequency of 20 kHz, and an ambient temperature of 85 °C are chosen. The 34981 is evaluated using the following board. The thermal impedance of the board is in the range of 15 °C/W.



Figure 39. 34981 Evaluation Board

### POWER DISSIPATION

Figure 40 illustrates the power dissipation in the 34981. The conditions are listed in Figure 38. Maximum power dissipation of 3.1 W is obtained with a duty of 95%.

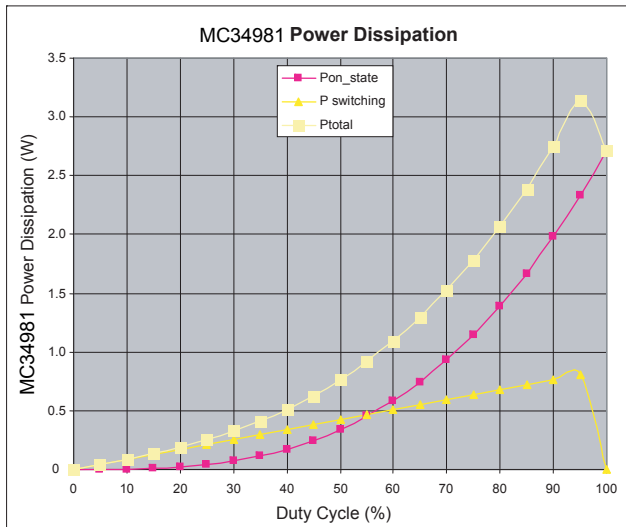

Figure 40. Power Dissipation (Pon and Pswitching) vs. Duty Cycle

### INFLUENCE OF SR CAPACITOR

The SR capacitor value has an impact on these switching losses. Figure 41 illustrates the percentage of the switching losses versus the total power dissipation for the same load conditions as Figure 38. The higher the SR capacitor value, the higher the switching losses. They can be more than 50% of the total power dissipation in the 34981 with a 4.7 nF capacitor and is a basic applications trade-off. A compromise should be found between the power dissipation and the electromagnetic capability (EMC) performance.

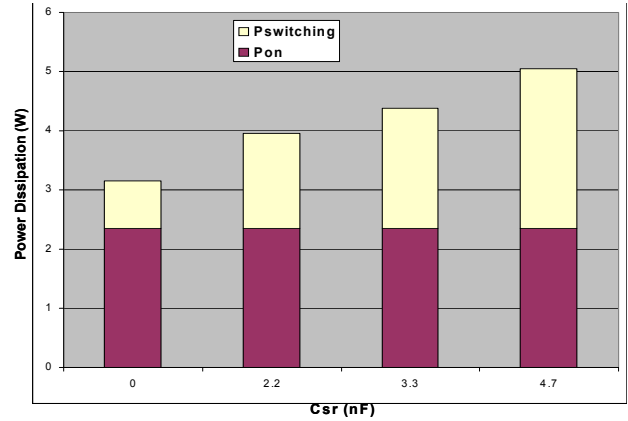

Figure 41. Power Switching vs. SR Capacitor

### RECIRCULATION PHASE

Figure 42 illustrates the power dissipation for the two recirculation approaches, diode or low side MOSFET. The power dissipation gain for the entire system when using the low side instead of the diode can reach up to 1.5 W with a duty cycle of 50%.

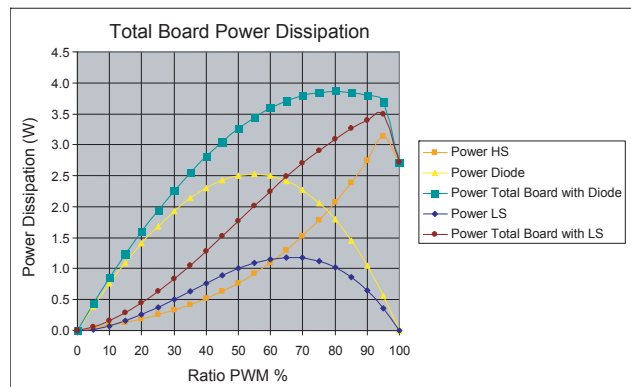

Figure 42. Total Board Power Dissipation



## JUNCTION TEMPERATURE

The junction temperature of the 34981 versus duty cycle for the condition listed in [Figure 38](#), is given in [Figure 43](#). The maximum obtained junction temperature is 132 °C with a duty cycle of 95%. This value is far from the 150°C maximum guaranteed junction.

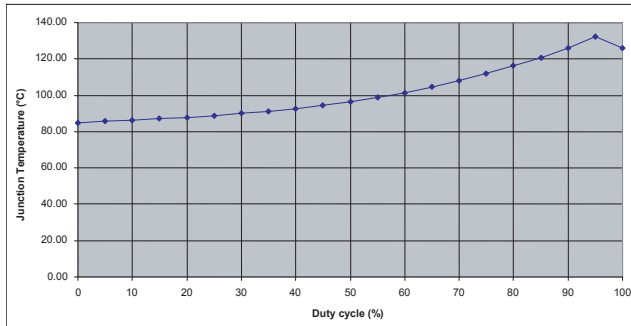

Figure 43. Junction Temperature vs. Duty Cycle

## CONCLUSION

Knowing the application conditions, this document explained how to calculate power dissipation during on-state and switching phases and the junction temperature for the 34981 when controlling a DC motor. A concrete example with a 200 W DC motor was given in [DC Motor 200W](#). The same principle can be used for other DC motors and other environmental conditions.

## PACKAGING

### SOLDERING INFORMATION

The 34981 is packaged in a surface mount power package (PQFN), intended to be soldered directly on the printed circuit board. The [AN2467](#) provides guidelines for Printed Circuit Board design and assembly.

### PACKAGING DIMENSIONS

For the most current package revision, visit [www.freescale.com](http://www.freescale.com) and perform a keyword search using "98ARL10521D". Dimensions shown are provided for reference ONLY.

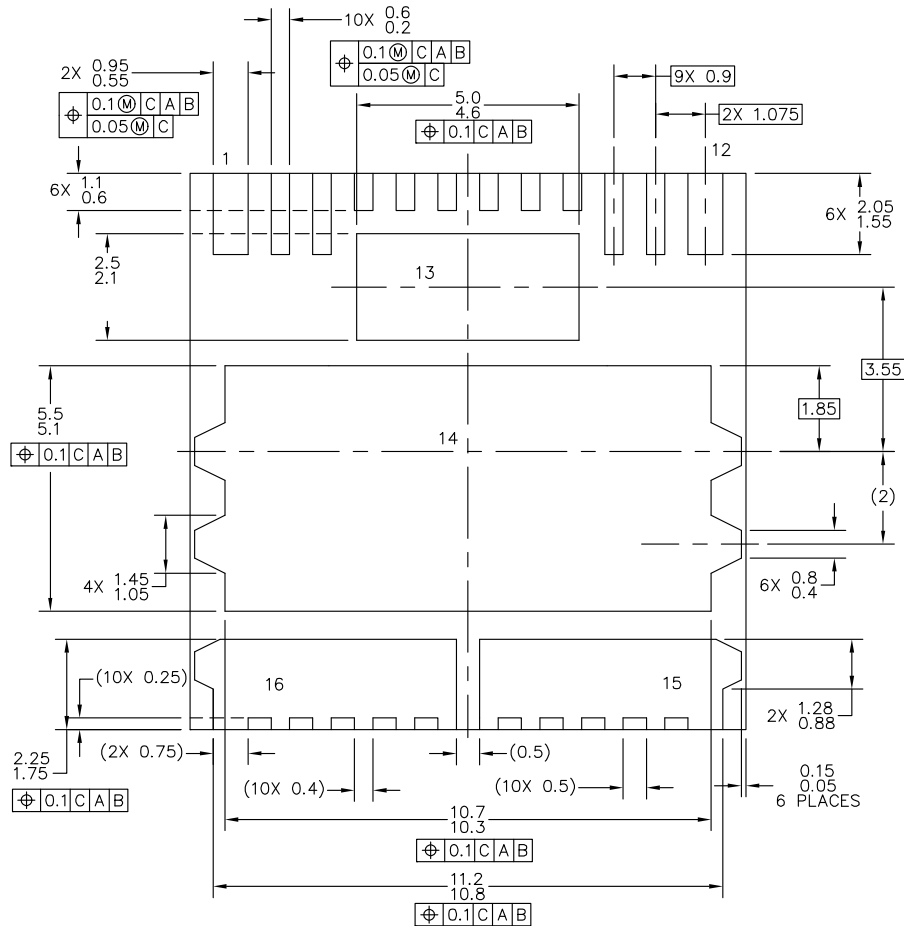

VIEW M-M

© FREESCALE SEMICONDUCTOR, INC. ALL RIGHTS RESERVED.	<b>MECHANICAL OUTLINE</b>	PRINT VERSION NOT TO SCALE	
TITLE: POWER QUAD FLAT NON-LEADED PACKAGE (PWR QFN) 16 TERMINAL, 0.9 PITCH(12X12X2.1)	DOCUMENT NO: 98ARL10521D	REV: C	27 APR 2005
	CASE NUMBER: 1402-02		
	STANDARD: NON-JEDEC		

**FK SUFFIX**  
16-PIN PQFN  
98ARL10521D  
ISSUE C

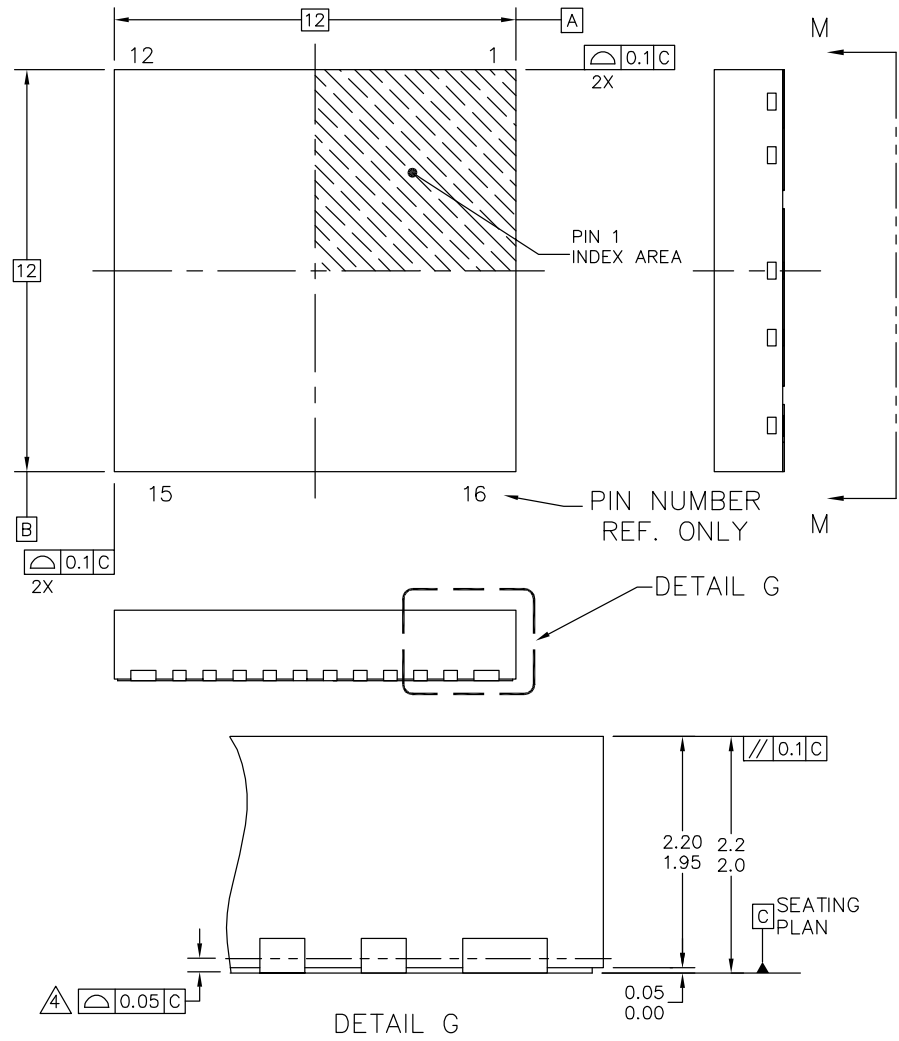

© FREESCALE SEMICONDUCTOR, INC. ALL RIGHTS RESERVED.	<b>MECHANICAL OUTLINE</b>	PRINT VERSION NOT TO SCALE	
TITLE: POWER QUAD FLAT NON-LEADED PACKAGE (PWR QFN) 16 TERMINAL, 0.9 PITCH(12X12X2.1)	DOCUMENT NO: 98ARL10521D	REV: C	
	CASE NUMBER: 1402-02	27 APR 2005	
	STANDARD: NON-JEDEC		

**FK SUFFIX**  
16-PIN PQFN  
98ARL10521D  
ISSUE C

## ADDITIONAL DOCUMENTATION

### THERMAL ADDENDUM (REV 3.0)

#### INTRODUCTION

This thermal addendum is provided as a supplement to the 34981 technical datasheet. The addendum provides thermal performance information critical in the design and development of system applications. All electrical, application, and packaging information is provided in the datasheet.

#### PACKAGING AND THERMAL CONSIDERATIONS

This package is a dual die package. There are two heat sources in the package independently heating with  $P_1$  and  $P_2$ . This results in two junction temperatures,  $T_{J1}$  and  $T_{J2}$ , and a thermal resistance matrix with  $R_{\theta JA mn}$ .

For  $m, n = 1$ ,  $R_{\theta JA11}$  is the thermal resistance from Junction 1 to the reference temperature while only heat source 1 is heating with  $P_1$ .

For  $m = 1, n = 2$ ,  $R_{\theta JA12}$  is the thermal resistance from Junction 1 to the reference temperature while heat source 2 is heating with  $P_2$ . This applies to  $R_{\theta J21}$  and  $R_{\theta J22}$ , respectively.

$$\begin{Bmatrix} T_{J1} \\ T_{J2} \end{Bmatrix} = \begin{bmatrix} R_{\theta JA11} & R_{\theta JA12} \\ R_{\theta JA21} & R_{\theta JA22} \end{bmatrix} \cdot \begin{Bmatrix} P_1 \\ P_2 \end{Bmatrix}$$

The stated values are solely for a thermal performance comparison of one package to another in a standardized environment. This methodology is not meant to and does not predict the performance of a package in an application-specific environment. Stated values were obtained by measurement and simulation according to the standards listed below.

#### STANDARDS

Table 8. Thermal Performance Comparison

Thermal Resistance	1 = Power Chip, 2 = Logic Chip [ $^{\circ}\text{C}/\text{W}$ ]		
	$m = 1, n = 1$	$m = 1, n = 2$ $m = 2, n = 1$	$m = 2, n = 2$
$P_{\theta JA mn}^{(1), (2)}$	22	18	41
$P_{\theta JB mn}^{(2), (3)}$	7.0	4.0	27
$P_{\theta JA mn}^{(1), (4)}$	62	48	81
$P_{\theta JC mn}^{(5)}$	<1.0	0.0	1.0

#### Notes

- Per JEDEC JESD51-2 at natural convection, still air condition.
- 2s2p thermal test board per JEDEC JESD51-7 and JESD51-5.
- Per JEDEC JESD51-8, with the board temperature on the center trace near the power outputs.
- Single layer thermal test board per JEDEC JESD51-3 and JESD51-5.
- Thermal resistance between the die junction and the exposed pad, "infinite" heat sink attached to exposed pad.

34981

---

16-PIN  
PQFN

---



98ARL10521D  
16-PIN PQFN  
12 MM X 12 MM

**Note** For package dimensions, refer to 98ARL10521D.

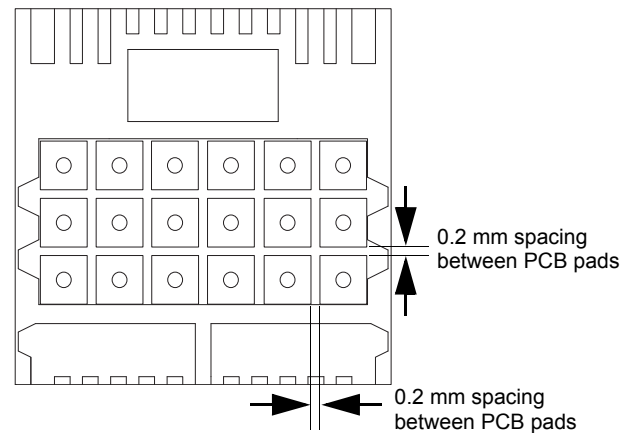

Note: Recommended via diameter is 0.5 mm. PTH (plated through hole) via must be plugged / filled with epoxy or solder mask in order to minimize void formation and to avoid any solder wicking into the via.

**Figure 44. Surface mount for power PQFN with exposed pads**

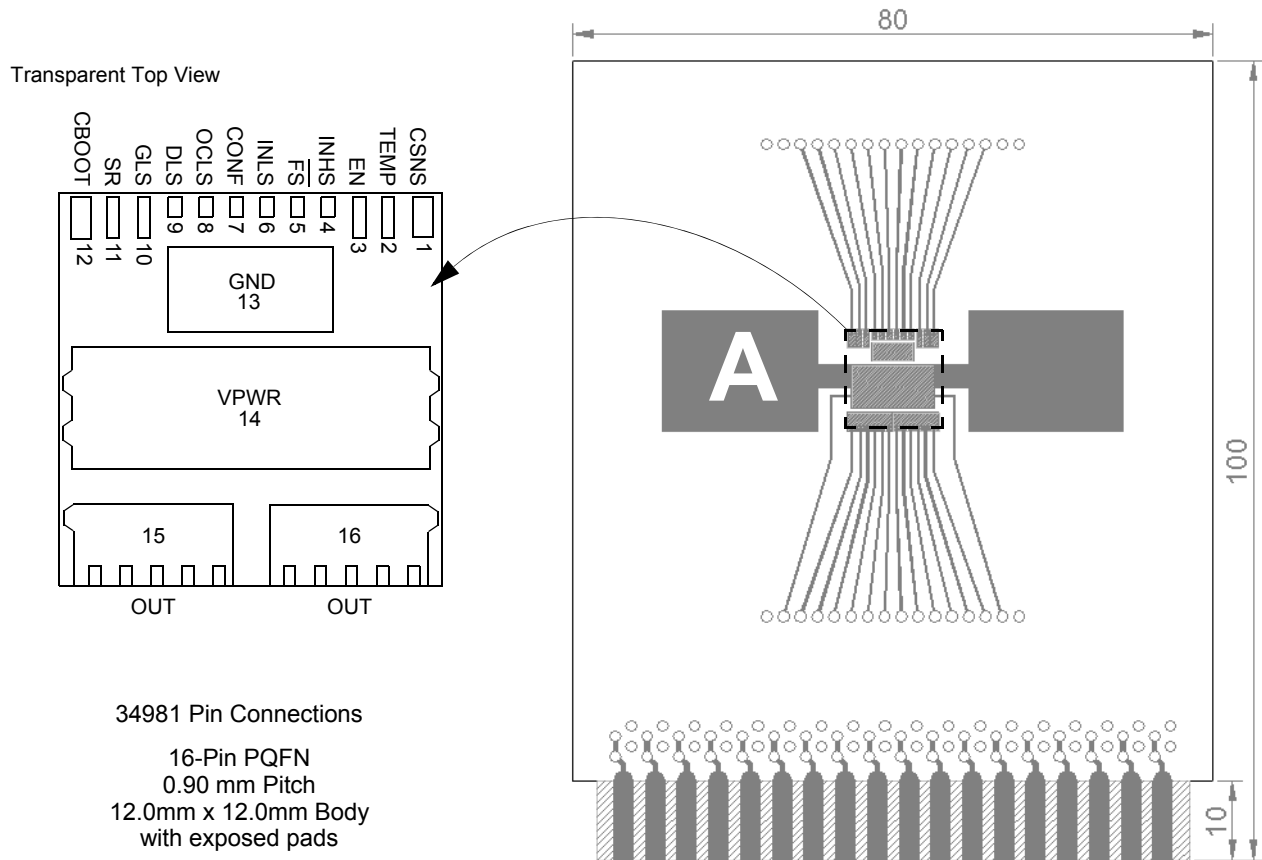

Figure 45. Thermal Test Board

**Device on Thermal Test Board**

- Material: Single layer printed circuit board  
FR4, 1.6 mm thickness  
Cu traces, 0.07 mm thickness
- Outline: 80 mm x 100 mm board area,  
including edge connector for thermal  
testing
- Area A: Cu heat-spreading areas on board  
surface
- Ambient Conditions: Natural convection, still air

**Table 9. Thermal Resistance Performance**

Thermal Resistance	Area A (mm <sup>2</sup> )	1 = Power Chip, 2 = Logic Chip (°C/W)		
		<i>m</i> = 1, <i>n</i> = 1	<i>m</i> = 1, <i>n</i> = 2 <i>m</i> = 2, <i>n</i> = 1	<i>m</i> = 2, <i>n</i> = 2
$P_{\theta JA mn}$	0	66	51	84
	300	47	37	73
	600	43	34	70

$R_{\theta JA}$  is the thermal resistance between die junction and ambient air.

This device is a dual die package. Index *m* indicates the die that is heated. Index *n* refers to the number of the die where the junction temperature is sensed.

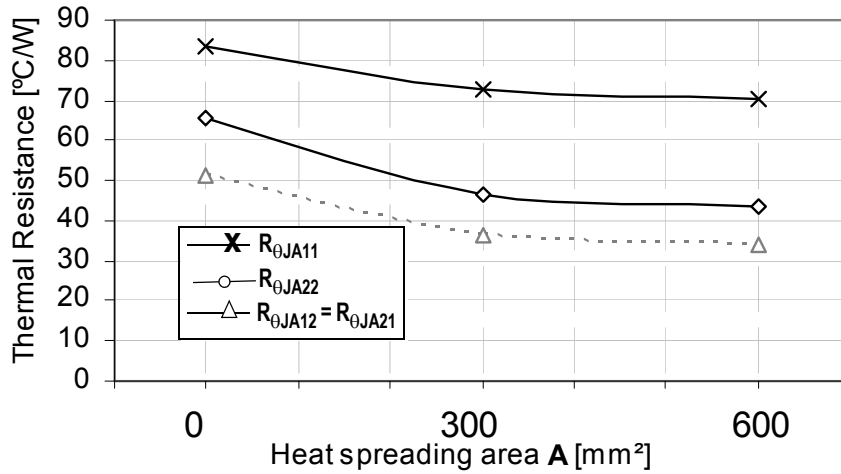

Figure 46. Device on Thermal Test Board R<sub>θJA</sub>

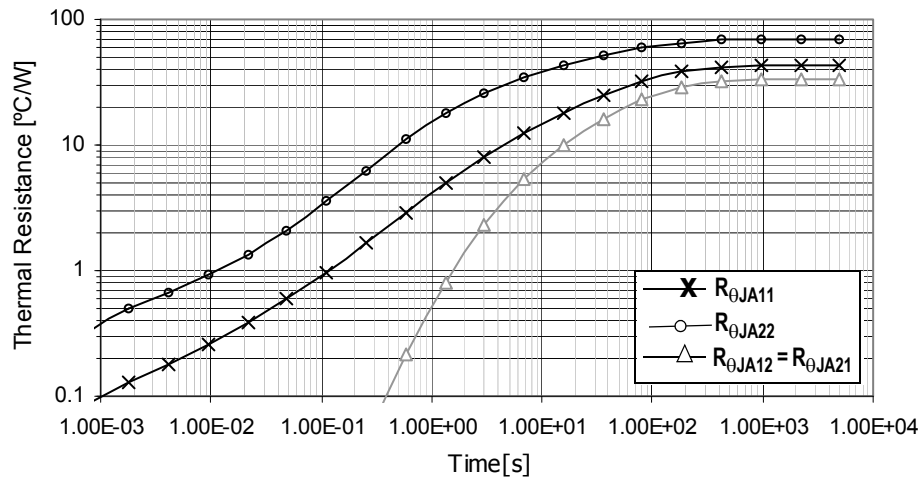

Figure 47. Transient Thermal Resistance R<sub>θJA</sub>,  
 1 W Step response, Device on Thermal Test Board Area A = 600(mm<sup>2</sup>)

## REVISION HISTORY

Revision	Date	Description of Changes
1.0	7/2013	<ul style="list-style-type: none"><li>Initial Release based on the 33981 data sheet</li></ul>
2.0	9/2013	<ul style="list-style-type: none"><li>Added the note "To achieve high reliability over 10 years of continuous operation, the device's continuous operating junction temperature should not exceed 125 °C." to <a href="#">Operating Temperature</a></li></ul>



**How to Reach Us:**

**Home Page:**  
freescale.com

**Web Support:**  
freescale.com/support

Information in this document is provided solely to enable system and software implementers to use Freescale products. There are no express or implied copyright licenses granted hereunder to design or fabricate any integrated circuits based on the information in this document.

Freescale reserves the right to make changes without further notice to any products herein. Freescale makes no warranty, representation, or guarantee regarding the suitability of its products for any particular purpose, nor does Freescale assume any liability arising out of the application or use of any product or circuit, and specifically disclaims any and all liability, including without limitation consequential or incidental damages. "Typical" parameters that may be provided in Freescale data sheets and/or specifications can and do vary in different applications, and actual performance may vary over time. All operating parameters, including "typicals," must be validated for each customer application by customer's technical experts. Freescale does not convey any license under its patent rights nor the rights of others. Freescale sells products pursuant to standard terms and conditions of sale, which can be found at the following address: [freescale.com/SalesTermsandConditions](http://freescale.com/SalesTermsandConditions).

Freescale and the Freescale logo, are trademarks of Freescale Semiconductor, Inc., Reg. U.S. Pat. & Tm. Off. SMARTMOS is a trademark of Freescale Semiconductor, Inc. All other product or service names are the property of their respective owners.

© 2013 Freescale Semiconductor, Inc.

Document Number: MC34981  
Rev. 2.0  
9/2013

