

Kinetis KV31F 256 KB Flash

120 MHz Cortex-M4 Based Microcontroller with FPU

The KV31 MCU family is a highly scalable member of the Kinetis V Series and provides a high-performance, cost-competitive motor control solution. Built on the ARM®Cortex®-M4 core running at 120 MHz, combined with floating point and DSP capability, it delivers a highly capable platform enabling customers to build a highly scalable solution portfolio.

Additional features include:

- Dual 16-bit ADCs sampling at up to 1.2 MS/s in 12-bit mode
- 12 channels of highly flexible motor control timers (PWMs) across 3 independent time bases
- Large RAM block enabling local execution of fast control loops at full clock speed

MKV31F256VLL12
MKV31F256VLH12

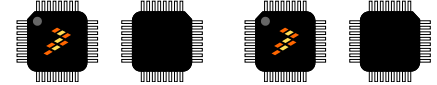

100 LQFP (LL) 64 LQFP (LH)
14 x 14 x 1.4 Pitch 0.5 mm 10 x 10 x 1.4 Pitch 0.5 mm

Performance

- 120 MHz ARM Cortex-M4 core with DSP instructions delivering 1.25 Dhrystone MIPS per MHz

Memories and memory interfaces

- 256 KB of embedded flash and 48 KB of RAM
- Serial programming interface (EzPort)
- Preprogrammed Kinetis flashloader for one-time, in-system factory programming

System peripherals

- Flexible low-power modes, multiple wake up sources
- 16-channel DMA controller
- Independent external and software watchdog monitor

Clocks

- One crystal oscillator, two ranges: 32-40 kHz or 3-32 MHz
- Three internal oscillators: 32 kHz, 4 MHz, and 48 MHz
- Multi-purpose clock generator with PLL and FLL

Security and integrity modules

- Hardware CRC module
- 128-bit unique identification (ID) number per chip
- Hardware random-number generator
- Flash access control to protect proprietary software

Human-machine interface

- Up to 70 general-purpose I/O (GPIO)

Analog modules

- Two 16-bit SAR ADCs converting at 1.2 MS/s in 12-bit mode
- One 12-bit DAC
- Two analog comparators (CMP) with 6-bit DAC
- Accurate internal voltage reference

Communication interfaces

- Two SPI modules
- Three UART modules and one low-power UART
- Two I2C modules: Support for up to 400 kbps operation with maximum bus loading

Timers

- One 8-channel motor control/general purpose/ PWM timer
- Two 2-channel motor control/general purpose timers with quadrature decoder functionality
- Periodic interrupt timers
- 16-bit low-power timer
- Programmable delay block

Operating Characteristics

- Voltage range: 1.71 to 3.6 V
- Flash write voltage range: 1.71 to 3.6 V
- Temperature range (ambient): -40 to 105°C

Ordering Information

Part Number	Memory		Number of GPIOs
	Flash (KB)	SRAM (KB)	
MKV31F256VLL12	256	48	70
MKV31F256VLH12	256	48	46

Related Resources

Type	Description
Selector Guide	The Freescale Solution Advisor is a web-based tool that features interactive application wizards and a dynamic product selector.
Product Brief	The Product Brief contains concise overview/summary information to enable quick evaluation of a device for design suitability.
Reference Manual	The Reference Manual contains a comprehensive description of the structure and function (operation) of a device.
Data Sheet	The Data Sheet includes electrical characteristics and signal connections.
Chip Errata	The chip mask set Errata provides additional or corrective information for a particular device mask set.
Package drawing	Package dimensions are provided in package drawings.

[Figure 1](#) shows the functional modules in the chip.

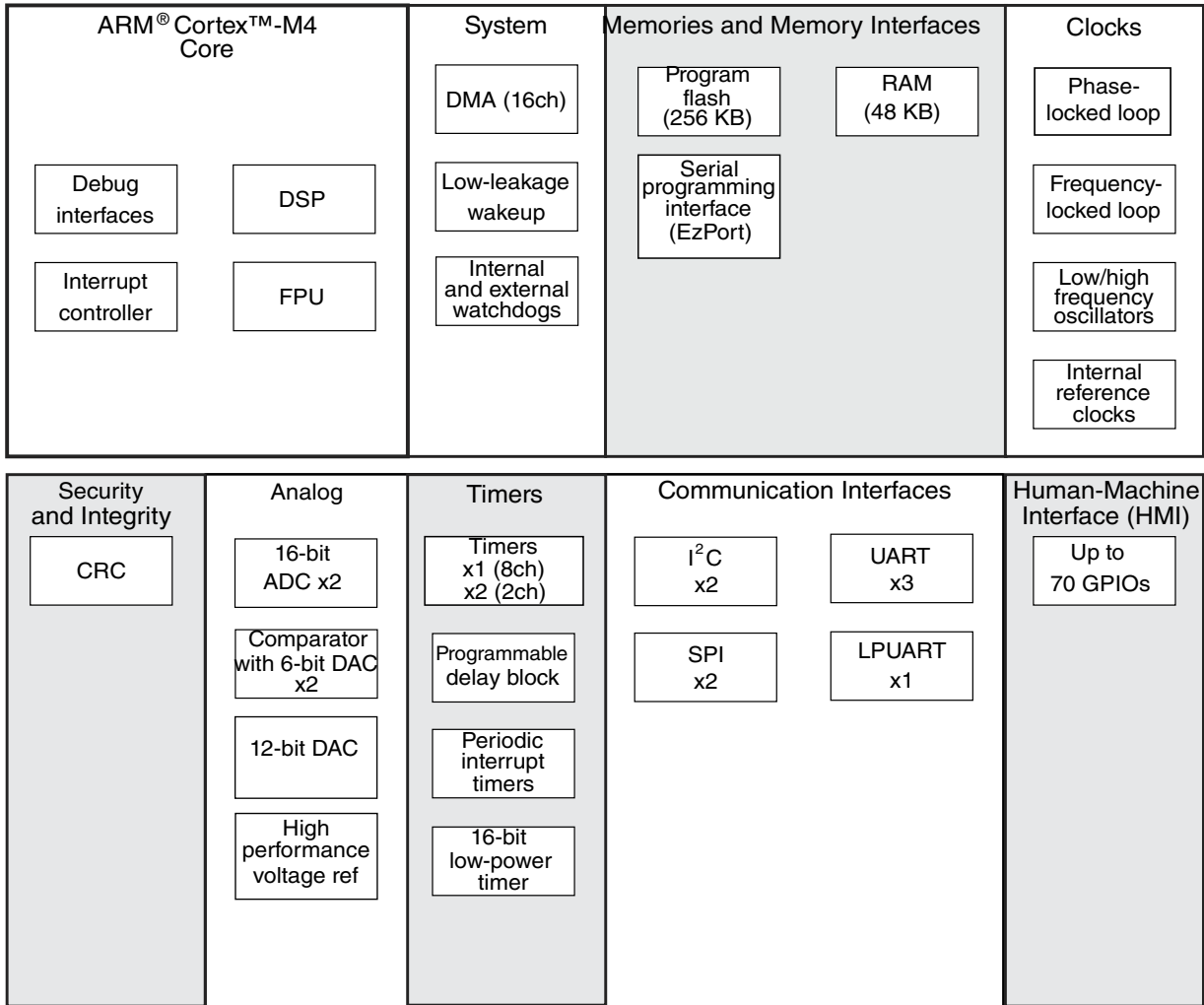

Figure 1. Functional block diagram

Table of Contents

1 Ratings.....	5	3.3.3 Oscillator electrical specifications.....	26
1.1 Thermal handling ratings.....	5	3.4 Memories and memory interfaces.....	28
1.2 Moisture handling ratings.....	5	3.4.1 Flash electrical specifications.....	28
1.3 ESD handling ratings.....	5	3.4.2 EzPort switching specifications.....	30
1.4 Voltage and current operating ratings.....	5	3.5 Security and integrity modules.....	31
2 General.....	6	3.6 Analog.....	31
2.1 AC electrical characteristics.....	6	3.6.1 ADC electrical specifications.....	31
2.2 Nonswitching electrical specifications.....	6	3.6.2 CMP and 6-bit DAC electrical specifications.....	36
2.2.1 Voltage and current operating requirements.....	6	3.6.3 12-bit DAC electrical characteristics.....	38
2.2.2 LVD and POR operating requirements.....	7	3.6.4 Voltage reference electrical specifications.....	41
2.2.3 Voltage and current operating behaviors.....	8	3.7 Timers.....	42
2.2.4 Power mode transition operating behaviors.....	9	3.8 Communication interfaces.....	42
2.2.5 Power consumption operating behaviors.....	10	3.8.1 DSPI switching specifications (limited voltage range).....	43
2.2.6 EMC radiated emissions operating behaviors.....	15	3.8.2 DSPI switching specifications (full voltage range).....	44
2.2.7 Designing with radiated emissions in mind.....	16	3.8.3 Inter-Integrated Circuit Interface (I2C) timing.....	46
2.2.8 Capacitance attributes.....	16	3.8.4 UART switching specifications.....	47
2.3 Switching specifications.....	16	4 Dimensions.....	47
2.3.1 Device clock specifications.....	16	4.1 Obtaining package dimensions.....	47
2.3.2 General switching specifications.....	17	5 Pinout.....	47
2.4 Thermal specifications.....	18	5.1 KV31F Signal Multiplexing and Pin Assignments.....	47
2.4.1 Thermal operating requirements.....	18	5.2 KV31F Pinouts.....	51
2.4.2 Thermal attributes.....	18	6 Ordering parts.....	53
3 Peripheral operating requirements and behaviors.....	19	6.1 Determining valid orderable parts.....	53
3.1 Core modules.....	19	7 Part identification.....	54
3.1.1 SWD electricals	19	7.1 Description.....	54
3.1.2 JTAG electricals.....	20	7.2 Format.....	54
3.2 System modules.....	23	7.3 Fields.....	54
3.3 Clock modules.....	23	7.4 Example.....	55
3.3.1 MCG specifications.....	23	8 Revision History.....	55
3.3.2 IRC48M specifications.....	26		

1 Ratings

1.1 Thermal handling ratings

Symbol	Description	Min.	Max.	Unit	Notes
T _{STG}	Storage temperature	-55	150	°C	1
T _{SDR}	Solder temperature, lead-free	—	260	°C	2

1. Determined according to JEDEC Standard JESD22-A103, *High Temperature Storage Life*.
2. Determined according to IPC/JEDEC Standard J-STD-020, *Moisture/Reflow Sensitivity Classification for Nonhermetic Solid State Surface Mount Devices*.

1.2 Moisture handling ratings

Symbol	Description	Min.	Max.	Unit	Notes
MSL	Moisture sensitivity level	—	3	—	1

1. Determined according to IPC/JEDEC Standard J-STD-020, *Moisture/Reflow Sensitivity Classification for Nonhermetic Solid State Surface Mount Devices*.

1.3 ESD handling ratings

Symbol	Description	Min.	Max.	Unit	Notes
V _{HBM}	Electrostatic discharge voltage, human body model	-2000	+2000	V	1
V _{CDM}	Electrostatic discharge voltage, charged-device model	-500	+500	V	2
I _{LAT}	Latch-up current at ambient temperature of 105°C	-100	+100	mA	3

1. Determined according to JEDEC Standard JESD22-A114, *Electrostatic Discharge (ESD) Sensitivity Testing Human Body Model (HBM)*.
2. Determined according to JEDEC Standard JESD22-C101, *Field-Induced Charged-Device Model Test Method for Electrostatic-Discharge-Withstand Thresholds of Microelectronic Components*.
3. Determined according to JEDEC Standard JESD78, *IC Latch-Up Test*.

1.4 Voltage and current operating ratings

General

Symbol	Description	Min.	Max.	Unit
V_{DD}	Digital supply voltage	-0.3	3.8	V
I_{DD}	Digital supply current	—	158	mA
V_{DIO}	Digital input voltage	-0.3	$V_{DD} + 0.3$	V
V_{AIO}	Analog ¹	-0.3	$V_{DD} + 0.3$	V
I_D	Maximum current single pin limit (applies to all digital pins)	-25	25	mA
V_{DDA}	Analog supply voltage	$V_{DD} - 0.3$	$V_{DD} + 0.3$	V

1. Analog pins are defined as pins that do not have an associated general purpose I/O port function.

2 General

2.1 AC electrical characteristics

Unless otherwise specified, propagation delays are measured from the 50% to the 50% point, and rise and fall times are measured at the 20% and 80% points, as shown in the following figure.

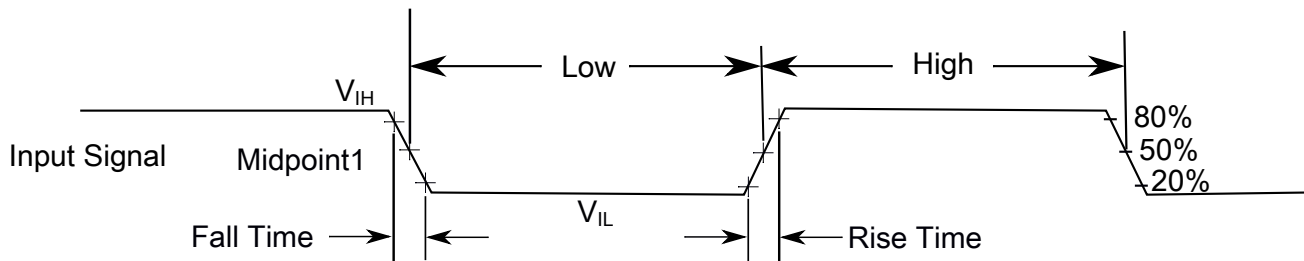

The midpoint is $V_{IL} + (V_{IH} - V_{IL}) / 2$

Figure 2. Input signal measurement reference

2.2 Nonswitching electrical specifications

2.2.1 Voltage and current operating requirements

Table 1. Voltage and current operating requirements

Symbol	Description	Min.	Max.	Unit	Notes
V_{DD}	Supply voltage	1.71	3.6	V	

Table continues on the next page...

Table 1. Voltage and current operating requirements (continued)

Symbol	Description	Min.	Max.	Unit	Notes
V _{DDA}	Analog supply voltage	1.71	3.6	V	
V _{DD} – V _{DDA}	V _{DD} -to-V _{DDA} differential voltage	–0.1	0.1	V	
V _{SS} – V _{SSA}	V _{SS} -to-V _{SSA} differential voltage	–0.1	0.1	V	
V _{IH}	Input high voltage <ul style="list-style-type: none"> • 2.7 V ≤ V_{DD} ≤ 3.6 V • 1.7 V ≤ V_{DD} ≤ 2.7 V 	0.7 × V _{DD}	—	V	
		0.75 × V _{DD}	—	V	
V _{IL}	Input low voltage <ul style="list-style-type: none"> • 2.7 V ≤ V_{DD} ≤ 3.6 V • 1.7 V ≤ V_{DD} ≤ 2.7 V 	—	0.35 × V _{DD}	V	
		—	0.3 × V _{DD}	V	
V _{HYS}	Input hysteresis	0.06 × V _{DD}	—	V	
I _{ICIO}	Analog and I/O pin DC injection current — single pin <ul style="list-style-type: none"> • V_{IN} < V_{SS}-0.3V (Negative current injection) • V_{IN} > V_{DD}+0.3V (Positive current injection) 	-3 —	— +3	mA	1
I _{ICcont}	Contiguous pin DC injection current —regional limit, includes sum of negative injection currents or sum of positive injection currents of 16 contiguous pins <ul style="list-style-type: none"> • Negative current injection • Positive current injection 	-25 —	— +25	mA	
V _{ODPU}	Open drain pullup voltage level	V _{DD}	V _{DD}	V	2
V _{RAM}	V _{DD} voltage required to retain RAM	1.2	—	V	

- All analog and I/O pins are internally clamped to V_{SS} and V_{DD} through ESD protection diodes. If V_{IN} is less than V_{IO_MIN} or greater than V_{IO_MAX}, a current limiting resistor is required. The negative DC injection current limiting resistor is calculated as $R=(V_{IO_MIN}-V_{IN})/|I_{ICIO}|$. The positive injection current limiting resistor is calculated as $R=(V_{IN}-V_{IO_MAX})/|I_{ICIO}|$. Select the larger of these two calculated resistances if the pin is exposed to positive and negative injection currents.
- Open drain outputs must be pulled to V_{DD}.

2.2.2 LVD and POR operating requirements

Table 2. V_{DD} supply LVD and POR operating requirements

Symbol	Description	Min.	Typ.	Max.	Unit	Notes
V _{POR}	Falling V _{DD} POR detect voltage	0.8	1.1	1.5	V	
V _{LVDH}	Falling low-voltage detect threshold — high range (LVDV=01)	2.48	2.56	2.64	V	
V _{LVW1H}	Low-voltage warning thresholds — high range <ul style="list-style-type: none"> • Level 1 falling (LVWV=00) 	2.62	2.70	2.78	V	1

Table continues on the next page...

Table 2. V_{DD} supply LVD and POR operating requirements (continued)

Symbol	Description	Min.	Typ.	Max.	Unit	Notes
V_{LVW2H}	• Level 2 falling (LVWV=01)	2.72	2.80	2.88	V	
V_{LVW3H}	• Level 3 falling (LVWV=10)	2.82	2.90	2.98	V	
V_{LVW4H}	• Level 4 falling (LVWV=11)	2.92	3.00	3.08	V	
V_{HYSH}	Low-voltage inhibit reset/recover hysteresis — high range	—	80	—	mV	
V_{LVDL}	Falling low-voltage detect threshold — low range (LVDV=00)	1.54	1.60	1.66	V	
V_{LVW1L}	Low-voltage warning thresholds — low range • Level 1 falling (LVWV=00)	1.74	1.80	1.86	V	1
V_{LVW2L}	• Level 2 falling (LVWV=01)	1.84	1.90	1.96	V	
V_{LVW3L}	• Level 3 falling (LVWV=10)	1.94	2.00	2.06	V	
V_{LVW4L}	• Level 4 falling (LVWV=11)	2.04	2.10	2.16	V	
V_{HYSL}	Low-voltage inhibit reset/recover hysteresis — low range	—	60	—	mV	
V_{BG}	Bandgap voltage reference	0.97	1.00	1.03	V	
t_{LPO}	Internal low power oscillator period — factory trimmed	900	1000	1100	μ s	

1. Rising threshold is the sum of falling threshold and hysteresis voltage

2.2.3 Voltage and current operating behaviors

Table 3. Voltage and current operating behaviors

Symbol	Description	Min.	Typ.	Max.	Unit	Notes
V_{OH}	Output high voltage — Normal drive pad • $2.7\text{ V} \leq V_{DD} \leq 3.6\text{ V}$, $I_{OH} = -5\text{ mA}$ • $1.71\text{ V} \leq V_{DD} \leq 2.7\text{ V}$, $I_{OH} = -2.5\text{ mA}$	$V_{DD} - 0.5$ $V_{DD} - 0.5$	— —	— —	V V	1
V_{OH}	Output high voltage — High drive pad • $2.7\text{ V} \leq V_{DD} \leq 3.6\text{ V}$, $I_{OH} = -20\text{ mA}$ • $1.71\text{ V} \leq V_{DD} \leq 2.7\text{ V}$, $I_{OH} = -10\text{ mA}$	$V_{DD} - 0.5$ $V_{DD} - 0.5$	— —	— —	V V	1
I_{OHT}	Output high current total for all ports	—	—	100	mA	
V_{OL}	Output low voltage — Normal drive pad • $2.7\text{ V} \leq V_{DD} \leq 3.6\text{ V}$, $I_{OL} = 5\text{ mA}$ • $1.71\text{ V} \leq V_{DD} \leq 2.7\text{ V}$, $I_{OL} = 2.5\text{ mA}$	— —	— —	0.5 0.5	V V	1
V_{OL}	Output low voltage — High drive pad	— —	— —	0.5 0.5	V V	1

Table continues on the next page...

Table 3. Voltage and current operating behaviors (continued)

Symbol	Description	Min.	Typ.	Max.	Unit	Notes
	<ul style="list-style-type: none"> • $2.7\text{ V} \leq V_{DD} \leq 3.6\text{ V}$, $I_{OL} = 20\text{ mA}$ • $1.71\text{ V} \leq V_{DD} \leq 2.7\text{ V}$, $I_{OL} = 10\text{ mA}$ 					
I_{OLT}	Output low current total for all ports	—	—	100	mA	
I_{IN}	Input leakage current (per pin) for full temperature range <ul style="list-style-type: none"> • All pins other than high drive port pins • High drive port pins 	—	0.002	0.5	μA	1, 2
I_{IN}	Input leakage current (total all pins) for full temperature range	—	—	1.0	μA	2
R_{PU}	Internal pullup resistors	20	—	50	k Ω	3
R_{PD}	Internal pulldown resistors	20	—	50	k Ω	4

1. PTB0, PTB1, PTC3, PTC4, PTD4, PTD5, PTD6, and PTD7 I/O have both high drive and normal drive capability selected by the associated PTx_PCRn[DSE] control bit. All other GPIOs are normal drive only.
2. Measured at $V_{DD}=3.6\text{V}$
3. Measured at V_{DD} supply voltage = V_{DD} min and $V_{input} = V_{SS}$
4. Measured at V_{DD} supply voltage = V_{DD} min and $V_{input} = V_{DD}$

2.2.4 Power mode transition operating behaviors

All specifications except t_{POR} , and $VLLSx \rightarrow \text{RUN}$ recovery times in the following table assume this clock configuration:

- CPU and system clocks = 80 MHz
- Bus clock = 40 MHz
- Flash clock = 20 MHz
- MCG mode: FEI

Table 4. Power mode transition operating behaviors

Symbol	Description	Min.	Typ.	Max.	Unit	Notes
t_{POR}	After a POR event, amount of time from the point V_{DD} reaches 1.71 V to execution of the first instruction across the operating temperature range of the chip.	—	—	300	μs	1
	<ul style="list-style-type: none"> • $VLLS0 \rightarrow \text{RUN}$ 	—	—	140	μs	
	<ul style="list-style-type: none"> • $VLLS1 \rightarrow \text{RUN}$ 	—	—	140	μs	
	<ul style="list-style-type: none"> • $VLLS2 \rightarrow \text{RUN}$ 	—	—	80	μs	

Table continues on the next page...

Table 4. Power mode transition operating behaviors (continued)

Symbol	Description	Min.	Typ.	Max.	Unit	Notes
	• VLLS3 → RUN	—	—	80	μs	
	• LLS2 → RUN	—	—	6	μs	
	• LLS3 → RUN	—	—	6	μs	
	• VLPS → RUN	—	—	5.7	μs	
	• STOP → RUN	—	—	5.7	μs	

1. Normal boot (FTFA_OPT[LPBOOT]=1)

2.2.5 Power consumption operating behaviors

Symbol	Description	Min.	Typ.	Max.	Unit	Notes
I _{DDA}	Analog supply current	—	—	See note	mA	1
I _{DD_HSRUN}	High Speed Run mode current - all peripheral clocks disabled, CoreMark benchmark code executing from flash <ul style="list-style-type: none"> • @ 1.8V • @ 3.0V 	— —	25.66 25.75	— —	mA mA	2, 3, 4
I _{DD_HSRUN}	High Speed Run mode current - all peripheral clocks disabled, code executing from flash <ul style="list-style-type: none"> • @ 1.8V • @ 3.0V 	— —	23.6 23.7	— —	mA mA	2
I _{DD_HSRUN}	High Speed Run mode current — all peripheral clocks enabled, code executing from flash <ul style="list-style-type: none"> • @ 1.8V • @ 3.0V 	— —	31.9 32.0	— —	mA mA	5
I _{DD_RUN}	Run mode current in compute operation - all peripheral clocks disabled, CoreMark benchmark code executing from flash <ul style="list-style-type: none"> • @ 1.8V • @ 3.0V 	— —	15.8 15.8	— —	mA mA	3, 4, 6
I _{DD_RUN}	Run mode current in compute operation - all peripheral clocks disabled, code executing from flash	—	13.83	—	mA	6

Table continues on the next page...

	<ul style="list-style-type: none"> • @ 1.8V • @ 3.0V 	—	13.83	—	mA	
I _{DD_RUN}	Run mode current — all peripheral clocks disabled, code executing from flash <ul style="list-style-type: none"> • @ 1.8V • @ 3.0V 	—	15.3	—	mA	7
		—	15.4	—	mA	
I _{DD_RUN}	Run mode current — all peripheral clocks enabled, code executing from flash <ul style="list-style-type: none"> • @ 1.8V • @ 3.0V • @ 25°C • @ 125°C 	—	20.4	—	mA	8
		—	20.5	—	mA	
		—	21.4	—	mA	
I _{DD_RUN}	Run mode current — Compute Operation, code executing from flash <ul style="list-style-type: none"> • @ 1.8V • @ 3.0V • @ 25°C • @ 125°C 	—	14.0	—	mA	9
		—	14.0	—	mA	
		—	15.0	—	mA	
I _{DD_WAIT}	Wait mode high frequency current at 3.0 V — all peripheral clocks disabled	—	8.1	—	mA	7
I _{DD_WAIT}	Wait mode reduced frequency current at 3.0 V — all peripheral clocks disabled	—	4.4	—	mA	10
I _{DD_VLPR}	Very-low-power run mode current in compute operation - all peripheral clocks disabled, CoreMark benchmark code executing from flash <ul style="list-style-type: none"> • @ 1.8V • @ 3.0V 	—	0.7	—	mA	3, 4, 11
		—	0.7	—	mA	
I _{DD_VLPR}	Very-low-power run mode current in compute operation - all peripheral clocks disabled, code executing from flash <ul style="list-style-type: none"> • @ 1.8V • @ 3.0V 	—	0.61	—	mA	11
		—	0.61	—	mA	
I _{DD_VLPR}	Very-low-power run mode current at 3.0 V — all peripheral clocks disabled	—	0.684	—	mA	12
I _{DD_VLPR}	Very-low-power run mode current at 3.0 V — all peripheral clocks enabled	—	1.1	—	mA	13
I _{DD_VLPW}	Very-low-power wait mode current at 3.0 V — all peripheral clocks disabled	—	0.382	—	mA	14
I _{DD_STOP}	Stop mode current at 3.0 V <ul style="list-style-type: none"> • @ -40 to 25°C 	—	0.27	0.420	mA	
		—	0.315	0.63	mA	
		—	0.449	1.1	mA	

Table continues on the next page...

General

	<ul style="list-style-type: none"> • @ 70°C • @ 105°C 					
I _{DD_VLPS}	Very-low-power stop mode current at 3.0 V <ul style="list-style-type: none"> • @ -40 to 25°C • @ 70°C • @ 105°C 	—	4.5	19.5	μA	
		—	16.8	68	μA	
		—	60.8	223	μA	
I _{DD_LLS3}	Low leakage stop mode 3 current at 3.0 V <ul style="list-style-type: none"> • @ -40 to 25°C • @ 70°C • @ 105°C 	—	2.6	4.2	μA	
		—	6.6	17.4	μA	
		—	21.0	60.4	μA	
I _{DD_LLS2}	Low leakage stop mode 2 current at 3.0 V <ul style="list-style-type: none"> • @ -40 to 25°C • @ 70°C • @ 105°C 	—	2.4	3.9	μA	
		—	5.3	12.5	μA	
		—	15.9	41.8	μA	
I _{DD_VLLS3}	Very low-leakage stop mode 3 current at 3.0 V <ul style="list-style-type: none"> • @ -40 to 25°C • @ 70°C • @ 105°C 	—	1.9	2.7	μA	
		—	4.8	11.4	μA	
		—	15.3	40	μA	
I _{DD_VLLS2}	Very low-leakage stop mode 2 current at 3.0 V <ul style="list-style-type: none"> • @ -40 to 25°C • @ 70°C • @ 105°C 	—	1.7	2.1	μA	
		—	3.4	6.3	μA	
		—	9.8	21.6	μA	
I _{DD_VLLS1}	Very low-leakage stop mode 1 current at 3.0 V <ul style="list-style-type: none"> • @ -40 to 25°C • @ 70°C • @ 105°C 	—	0.730	1.2	μA	
		—	1.8	2.4	μA	
		—	5.7	10.5	μA	
I _{DD_VLLS0}	Very low-leakage stop mode 0 current at 3.0 V with POR detect circuit enabled <ul style="list-style-type: none"> • @ -40 to 25°C • @ 70°C • @ 105°C 	—	0.430	0.6	μA	
		—	1.4	2.0	μA	
		—	5.3	9.7	μA	
I _{DD_VLLS0}	Very low-leakage stop mode 0 current at 3.0 V with POR detect circuit disabled <ul style="list-style-type: none"> • @ -40 to 25°C • @ 70°C • @ 105°C 	—	0.140	0.29	μA	
		—	1.1	1.7	μA	
		—	4.9	9.3	μA	

1. The analog supply current is the sum of the active or disabled current for each of the analog modules on the device. See each module's specification for its supply current.
2. 120MHz core and system clock, 60MHz bus clock, and 24MHz flash clock. MCG configured for PEE mode. All peripheral clocks disabled.
3. Cache on and prefetch on, low compiler optimization.
4. Coremark benchmark compiled using IAR 7.2 with optimization level low.
5. 120MHz core and system clock, 60MHz bus clock, and 24MHz flash clock. MCG configured for PEE mode. All peripheral clocks enabled.
6. 80 MHz core and system clock, 40 MHz bus clock, and 26.67 MHz flash clock. MCG configured for PEE mode. All peripheral clocks disabled. Compute operation.
7. 80MHz core and system clock, 40MHz bus clock, and 26.67MHz flash clock. MCG configured for FEI mode. All peripheral clocks disabled.
8. 80MHz core and system clock, 40MHz bus clock, and 26.67MHz flash clock. MCG configured for FEI mode. All peripheral clocks enabled.
9. 80MHz core and system clock, 40MHz bus clock, and 26.67MHz flash clock. MCG configured for FEI mode. Compute Operation.
10. 25MHz core and system clock, 25MHz bus clock, and 25MHz flash clock. MCG configured for FEI mode.
11. 4 MHz core, system, and bus clock and 1MHz flash clock. MCG configured for BLPE mode. Compute Operation. Code executing from flash.
12. 4 MHz core, system, and bus clock and 1MHz flash clock. MCG configured for BLPE mode. All peripheral clocks disabled. Code executing from flash.
13. 4 MHz core, system, and bus clock and 1MHz flash clock. MCG configured for BLPE mode. All peripheral clocks enabled but peripherals are not in active operation. Code executing from flash.
14. 4 MHz core, system, and bus clock and 1MHz flash clock. MCG configured for BLPE mode. All peripheral clocks disabled.

2.2.5.1 Diagram: Typical IDD_RUN operating behavior

The following data was measured under these conditions:

- MCG in FBE mode for 50 MHz and lower frequencies. MCG in FEE mode at frequencies between 50 MHz and 100MHz. MCG in PEE mode at frequencies greater than 100 MHz.
- No GPIOs toggled
- Code execution from flash with cache enabled
- For the ALLOFF curve, all peripheral clocks are disabled except FTFA

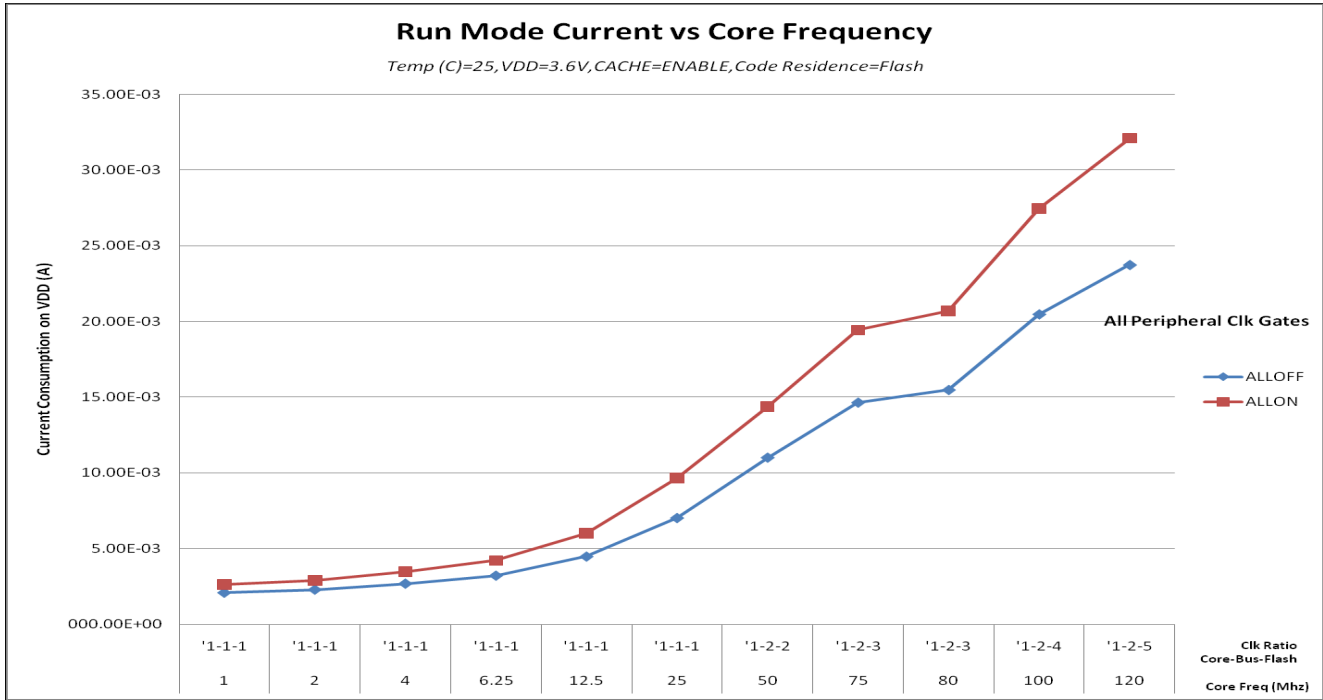

Figure 3. Run mode supply current vs. core frequency

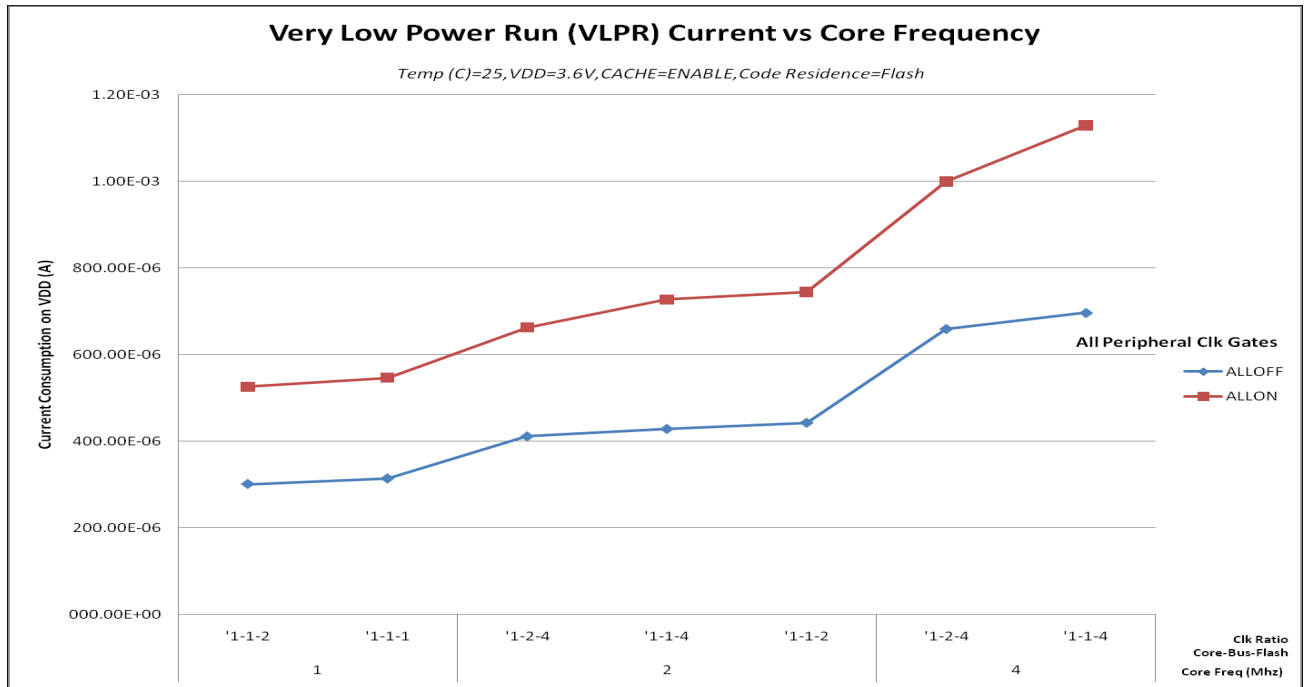

Figure 4. VLPR mode supply current vs. core frequency

2.2.6 EMC radiated emissions operating behaviors

Table 5. EMC radiated emissions operating behaviors for 64 LQFP package

Symbol	Description	Frequency band (MHz)	Typ.	Unit	Notes
V _{RE1}	Radiated emissions voltage, band 1	0.15–50	14	dBμV	1, 2
V _{RE2}	Radiated emissions voltage, band 2	50–150	23	dBμV	
V _{RE3}	Radiated emissions voltage, band 3	150–500	23	dBμV	
V _{RE4}	Radiated emissions voltage, band 4	500–1000	9	dBμV	
V _{RE_IEC}	IEC level	0.15–1000	L	—	2, 3,

1. Determined according to IEC Standard 61967-1, *Integrated Circuits - Measurement of Electromagnetic Emissions, 150 kHz to 1 GHz Part 1: General Conditions and Definitions* and IEC Standard 61967-2, *Integrated Circuits - Measurement of Electromagnetic Emissions, 150 kHz to 1 GHz Part 2: Measurement of Radiated Emissions—TEM Cell and Wideband TEM Cell Method*. Measurements were made while the microcontroller was running basic

General

application code. The reported emission level is the value of the maximum measured emission, rounded up to the next whole number, from among the measured orientations in each frequency range.

2. $V_{DD} = 3.3\text{ V}$, $T_A = 25\text{ }^\circ\text{C}$, $f_{OSC} = 8\text{ MHz}$ (crystal), $f_{SYS} = 120\text{ MHz}$, $f_{BUS} = 60\text{ MHz}$
3. Specified according to Annex D of IEC Standard 61967-2, *Measurement of Radiated Emissions—TEM Cell and Wideband TEM Cell Method*.

2.2.7 Designing with radiated emissions in mind

To find application notes that provide guidance on designing your system to minimize interference from radiated emissions:

1. Go to www.freescale.com.
2. Perform a keyword search for “EMC design.”

2.2.8 Capacitance attributes

Table 6. Capacitance attributes

Symbol	Description	Min.	Max.	Unit
C_{IN_A}	Input capacitance: analog pins	—	7	pF
C_{IN_D}	Input capacitance: digital pins	—	7	pF

2.3 Switching specifications

2.3.1 Device clock specifications

Table 7. Device clock specifications

Symbol	Description	Min.	Max.	Unit	Notes
High Speed run mode					
f_{SYS}	System and core clock	—	120	MHz	
f_{BUS}	Bus clock	—	60	MHz	
Normal run mode (and High Speed run mode unless otherwise specified above)					
f_{SYS}	System and core clock	—	80	MHz	
f_{BUS}	Bus clock	—	50	MHz	
f_{FLASH}	Flash clock	—	26.67	MHz	
f_{LPTMR}	LPTMR clock	—	25	MHz	
VLPR mode ¹					
f_{SYS}	System and core clock	—	4	MHz	

Table continues on the next page...

Table 7. Device clock specifications (continued)

Symbol	Description	Min.	Max.	Unit	Notes
f _{BUS}	Bus clock	—	4	MHz	
f _{FLASH}	Flash clock	—	1	MHz	
f _{ERCLK}	External reference clock	—	16	MHz	
f _{LPTMR_pin}	LPTMR clock	—	25	MHz	
f _{LPTMR_ERCLK}	LPTMR external reference clock	—	16	MHz	

1. The frequency limitations in VLPR mode here override any frequency specification listed in the timing specification for any other module.

2.3.2 General switching specifications

These general purpose specifications apply to all signals configured for GPIO, UART, and timers.

Table 8. General switching specifications

Symbol	Description	Min.	Max.	Unit	Notes
	GPIO pin interrupt pulse width (digital glitch filter disabled) — Synchronous path	1.5	—	Bus clock cycles	1, 2
	External RESET and NMI pin interrupt pulse width — Asynchronous path	100	—	ns	3
	GPIO pin interrupt pulse width (digital glitch filter disabled, passive filter disabled) — Asynchronous path	50	—	ns	4
	Mode select ($\overline{\text{EZP_CS}}$) hold time after reset deassertion	2	—	Bus clock cycles	
	Port rise and fall time <ul style="list-style-type: none"> • Slew disabled <ul style="list-style-type: none"> • $1.71 \leq V_{DD} \leq 2.7V$ • $2.7 \leq V_{DD} \leq 3.6V$ • Slew enabled <ul style="list-style-type: none"> • $1.71 \leq V_{DD} \leq 2.7V$ • $2.7 \leq V_{DD} \leq 3.6V$ 	—	—	ns	5

1. This is the minimum pulse width that is guaranteed to pass through the pin synchronization circuitry. Shorter pulses may or may not be recognized. In Stop, VLPS, LLS, and VLLSx modes, the synchronizer is bypassed so shorter pulses can be recognized in that case.
2. The greater of synchronous and asynchronous timing must be met.
3. These pins have a passive filter enabled on the inputs. This is the shortest pulse width that is guaranteed to be recognized.
4. These pins do not have a passive filter on the inputs. This is the shortest pulse width that is guaranteed to be recognized.
5. 25 pF load

2.4 Thermal specifications

2.4.1 Thermal operating requirements

Table 9. Thermal operating requirements

Symbol	Description	Min.	Max.	Unit
T_J	Die junction temperature	-40	125	°C
T_A	Ambient temperature	-40	105	°C

2.4.2 Thermal attributes

Board type	Symbol	Description	100 LQFP	64 LQFP	Unit	Notes
Single-layer (1s)	$R_{\theta JA}$	Thermal resistance, junction to ambient (natural convection)	61	67	°C/W	1
Four-layer (2s2p)	$R_{\theta JA}$	Thermal resistance, junction to ambient (natural convection)	48	48	°C/W	2
Single-layer (1s)	$R_{\theta JMA}$	Thermal resistance, junction to ambient (200 ft./min. air speed)	51	55	°C/W	3
Four-layer (2s2p)	$R_{\theta JMA}$	Thermal resistance, junction to ambient (200 ft./min. air speed)	42	42	°C/W	3
—	$R_{\theta JB}$	Thermal resistance, junction to board	34	31	°C/W	4
—	$R_{\theta JC}$	Thermal resistance, junction to case	16	16	°C/W	5

Table continues on the next page...

Board type	Symbol	Description	100 LQFP	64 LQFP	Unit	Notes
—	Ψ_{JT}	Thermal characterization parameter, junction to package top outside center (natural convection)	3	3	°C/W	6

1. Determined according to JEDEC Standard JESD51-2, *Integrated Circuits Thermal Test Method Environmental Conditions—Natural Convection (Still Air)* with the single layer board horizontal. Board meets JESD51-9 specification.
2. Determined according to JEDEC Standard JESD51-2, *Integrated Circuits Thermal Test Method Environmental Conditions—Natural Convection (Still Air)*.
3. Determined according to JEDEC Standard JESD51-6, *Integrated Circuits Thermal Test Method Environmental Conditions—Forced Convection (Moving Air)* with the board horizontal.
4. Determined according to JEDEC Standard JESD51-8, *Integrated Circuit Thermal Test Method Environmental Conditions—Junction-to-Board*.
5. Thermal resistance between the die and the case top surface as measured by the cold plate method (MIL SPEC-883 Method 1012.1).
6. Thermal characterization parameter indicating the temperature difference between package top and the junction temperature per JEDEC JESD51-2.

3 Peripheral operating requirements and behaviors

3.1 Core modules

3.1.1 SWD electricals

Table 10. SWD full voltage range electricals

Symbol	Description	Min.	Max.	Unit
	Operating voltage	1.71	3.6	V
S1	SWD_CLK frequency of operation <ul style="list-style-type: none"> • Serial wire debug 	0	33	MHz
S2	SWD_CLK cycle period	1/S1	—	ns
S3	SWD_CLK clock pulse width <ul style="list-style-type: none"> • Serial wire debug 	15	—	ns
S4	SWD_CLK rise and fall times	—	3	ns
S9	SWD_DIO input data setup time to SWD_CLK rise	8	—	ns
S10	SWD_DIO input data hold time after SWD_CLK rise	1.4	—	ns
S11	SWD_CLK high to SWD_DIO data valid	—	25	ns
S12	SWD_CLK high to SWD_DIO high-Z	5	—	ns

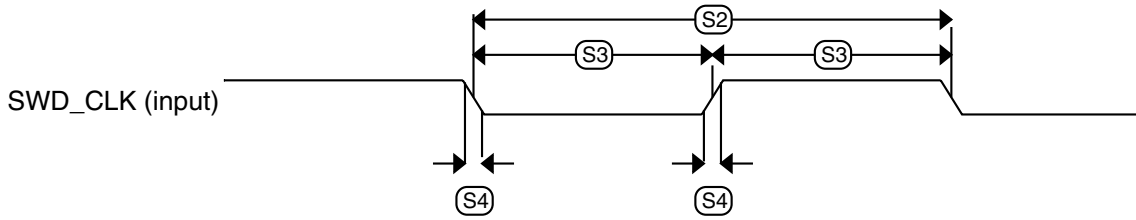

Figure 5. Serial wire clock input timing

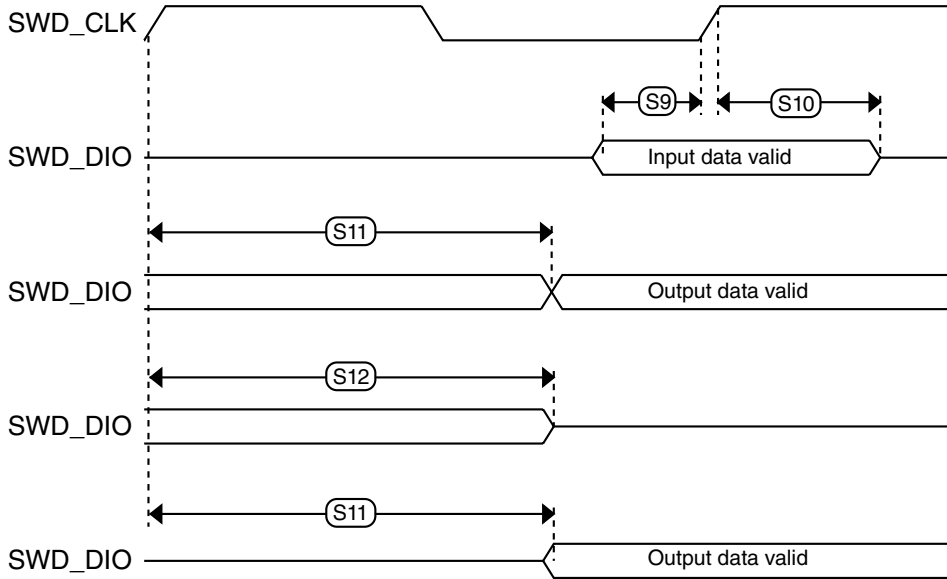

Figure 6. Serial wire data timing

3.1.2 JTAG electricals

Table 11. JTAG limited voltage range electricals

Symbol	Description	Min.	Max.	Unit
	Operating voltage	2.7	3.6	V
J1	TCLK frequency of operation <ul style="list-style-type: none"> • Boundary Scan • JTAG and CJTAG 	0 0	10 20	MHz
J2	TCLK cycle period	1/J1	—	ns
J3	TCLK clock pulse width	50	—	ns

Table continues on the next page...

Table 11. JTAG limited voltage range electricals (continued)

Symbol	Description	Min.	Max.	Unit
	<ul style="list-style-type: none"> Boundary Scan JTAG and CJTAG 	25	—	ns
J4	TCLK rise and fall times	—	3	ns
J5	Boundary scan input data setup time to TCLK rise	20	—	ns
J6	Boundary scan input data hold time after TCLK rise	1	—	ns
J7	TCLK low to boundary scan output data valid	—	25	ns
J8	TCLK low to boundary scan output high-Z	—	25	ns
J9	TMS, TDI input data setup time to TCLK rise	8	—	ns
J10	TMS, TDI input data hold time after TCLK rise	1	—	ns
J11	TCLK low to TDO data valid	—	19	ns
J12	TCLK low to TDO high-Z	—	19	ns
J13	$\overline{\text{TRST}}$ assert time	100	—	ns
J14	$\overline{\text{TRST}}$ setup time (negation) to TCLK high	8	—	ns

Table 12. JTAG full voltage range electricals

Symbol	Description	Min.	Max.	Unit
	Operating voltage	1.71	3.6	V
J1	TCLK frequency of operation			MHz
	<ul style="list-style-type: none"> Boundary Scan JTAG and CJTAG 	0	10	
		0	15	
J2	TCLK cycle period	1/J1	—	ns
J3	TCLK clock pulse width			
	<ul style="list-style-type: none"> Boundary Scan JTAG and CJTAG 	50	—	ns
		33	—	ns
J4	TCLK rise and fall times	—	3	ns
J5	Boundary scan input data setup time to TCLK rise	20	—	ns
J6	Boundary scan input data hold time after TCLK rise	1.4	—	ns
J7	TCLK low to boundary scan output data valid	—	27	ns
J8	TCLK low to boundary scan output high-Z	—	27	ns
J9	TMS, TDI input data setup time to TCLK rise	8	—	ns
J10	TMS, TDI input data hold time after TCLK rise	1.4	—	ns
J11	TCLK low to TDO data valid	—	26.2	ns
J12	TCLK low to TDO high-Z	—	26.2	ns
J13	$\overline{\text{TRST}}$ assert time	100	—	ns
J14	$\overline{\text{TRST}}$ setup time (negation) to TCLK high	8	—	ns

Peripheral operating requirements and behaviors

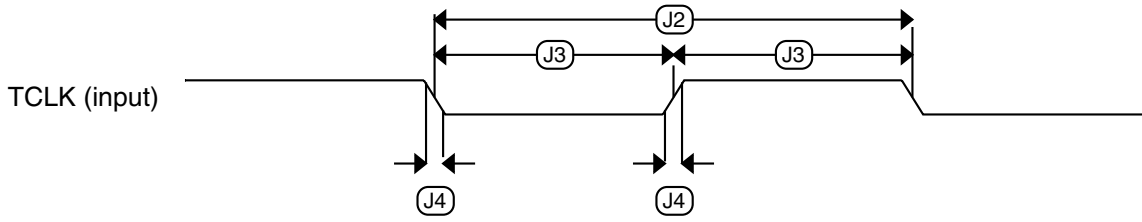

Figure 7. Test clock input timing

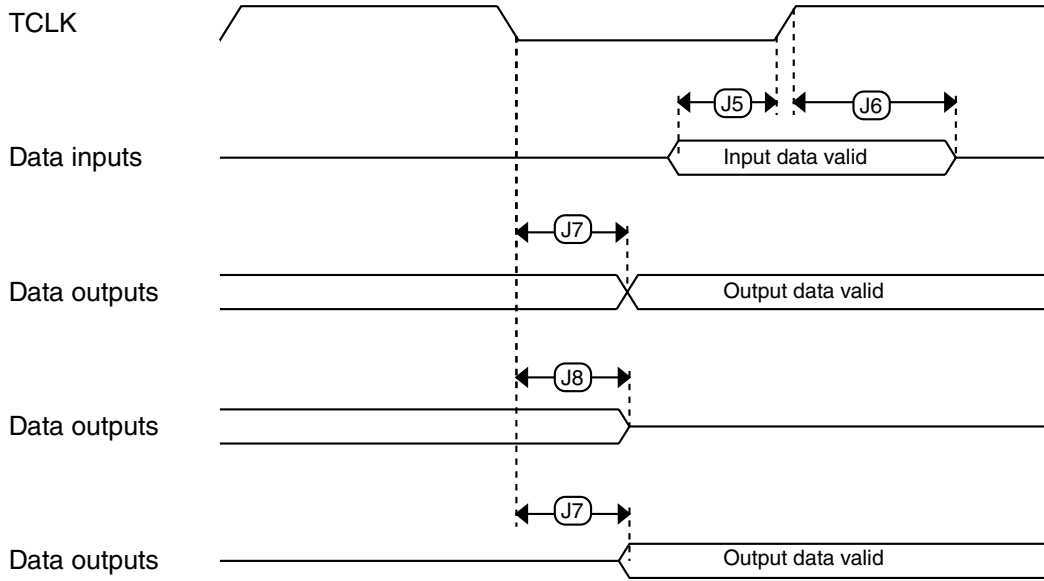

Figure 8. Boundary scan (JTAG) timing

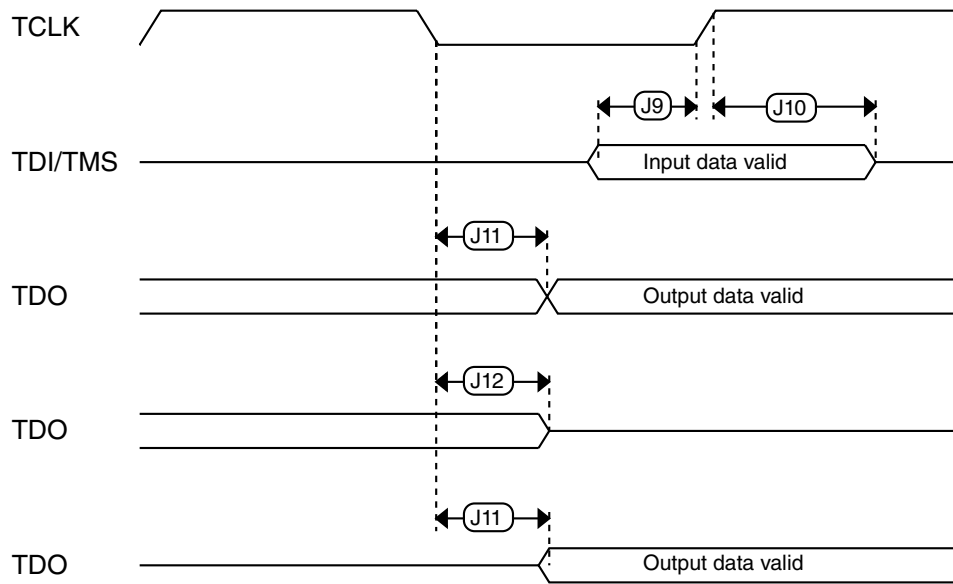
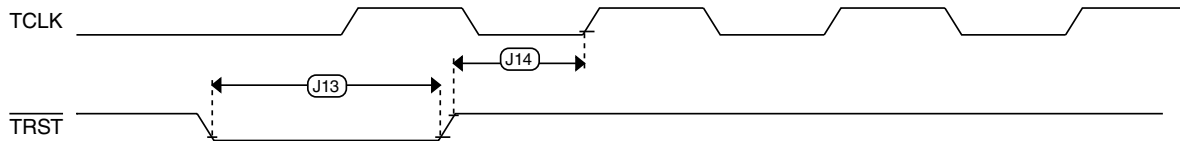

Figure 9. Test Access Port timing

Figure 10. $\overline{\text{TRST}}$ timing

3.2 System modules

There are no specifications necessary for the device's system modules.

3.3 Clock modules

3.3.1 MCG specifications

Table 13. MCG specifications

Symbol	Description	Min.	Typ.	Max.	Unit	Notes	
$f_{\text{ints_ft}}$	Internal reference frequency (slow clock) — factory trimmed at nominal VDD and 25 °C	—	32.768	—	kHz		
$\Delta f_{\text{ints_t}}$	Total deviation of internal reference frequency (slow clock) over voltage and temperature	—	+0.5/-0.7	± 2	%		
$f_{\text{ints_t}}$	Internal reference frequency (slow clock) — user trimmed	31.25	—	39.0625	kHz		
$\Delta f_{\text{dco_res_t}}$	Resolution of trimmed average DCO output frequency at fixed voltage and temperature — using SCTRIM and SCFTRIM	—	± 0.3	± 0.6	% f_{dco}	1	
$\Delta f_{\text{dco_t}}$	Total deviation of trimmed average DCO output frequency over voltage and temperature	—	+0.5/-0.7	± 2	% f_{dco}	1, 2	
$\Delta f_{\text{dco_t}}$	Total deviation of trimmed average DCO output frequency over fixed voltage and temperature range of 0–70°C	—	± 0.3	± 1.5	% f_{dco}	1	
$f_{\text{intf_ft}}$	Internal reference frequency (fast clock) — factory trimmed at nominal VDD and 25°C	—	4	—	MHz		
$\Delta f_{\text{intf_ft}}$	Frequency deviation of internal reference clock (fast clock) over temperature and voltage — factory trimmed at nominal VDD and 25 °C	—	+1/-2	± 5	% $f_{\text{intf_ft}}$		
$f_{\text{intf_t}}$	Internal reference frequency (fast clock) — user trimmed at nominal VDD and 25 °C	3	—	5	MHz		
$f_{\text{loc_low}}$	Loss of external clock minimum frequency — RANGE = 00	$(3/5) \times f_{\text{ints_t}}$	—	—	kHz		
$f_{\text{loc_high}}$	Loss of external clock minimum frequency — RANGE = 01, 10, or 11	$(16/5) \times f_{\text{ints_t}}$	—	—	kHz		
FLL							
$f_{\text{fll_ref}}$	FLL reference frequency range	31.25	—	39.0625	kHz		
f_{dco}	DCO output frequency range	Low range (DRS=00) $640 \times f_{\text{fll_ref}}$	20	20.97	25	MHz	3, 4
		Mid range (DRS=01) $1280 \times f_{\text{fll_ref}}$	40	41.94	50	MHz	
		Mid-high range (DRS=10) $1920 \times f_{\text{fll_ref}}$	60	62.91	75	MHz	
		High range (DRS=11) $2560 \times f_{\text{fll_ref}}$	80	83.89	100	MHz	
$f_{\text{dco_t_DMX3}}_2$	DCO output frequency	Low range (DRS=00) $732 \times f_{\text{fll_ref}}$	—	23.99	—	MHz	5, 6
		Mid range (DRS=01) $1464 \times f_{\text{fll_ref}}$	—	47.97	—	MHz	
		Mid-high range (DRS=10)	—	71.99	—	MHz	

Table continues on the next page...

Table 13. MCG specifications (continued)

Symbol	Description	Min.	Typ.	Max.	Unit	Notes
J_{cyc_fll}	FLL period jitter <ul style="list-style-type: none"> $f_{VCO} = 48$ MHz $f_{VCO} = 98$ MHz 	—	—	—	ps	
$t_{fil_acquire}$	FLL target frequency acquisition time	—	—	1	ms	7
PLL						
f_{vco}	VCO operating frequency	48.0	—	120	MHz	
I_{pll}	PLL operating current <ul style="list-style-type: none"> PLL @ 96 MHz ($f_{osc_hi_1} = 8$ MHz, $f_{pll_ref} = 2$ MHz, VDIV multiplier = 48) 	—	1060	—	μ A	8
I_{pll}	PLL operating current <ul style="list-style-type: none"> PLL @ 48 MHz ($f_{osc_hi_1} = 8$ MHz, $f_{pll_ref} = 2$ MHz, VDIV multiplier = 24) 	—	600	—	μ A	8
f_{pll_ref}	PLL reference frequency range	2.0	—	4.0	MHz	
J_{cyc_pll}	PLL period jitter (RMS) <ul style="list-style-type: none"> $f_{vco} = 48$ MHz $f_{vco} = 100$ MHz 	—	120	—	ps	9
		—	75	—	ps	
J_{acc_pll}	PLL accumulated jitter over 1 μ s (RMS) <ul style="list-style-type: none"> $f_{vco} = 48$ MHz $f_{vco} = 100$ MHz 	—	1350	—	ps	9
		—	600	—	ps	
D_{lock}	Lock entry frequency tolerance	± 1.49	—	± 2.98	%	
D_{unl}	Lock exit frequency tolerance	± 4.47	—	± 5.97	%	
t_{pll_lock}	Lock detector detection time	—	—	$150 \times 10^{-6} + 1075(1/f_{pll_ref})$	s	10

- This parameter is measured with the internal reference (slow clock) being used as a reference to the FLL (FEI clock mode).
- 2.0 V \leq VDD \leq 3.6 V.
- These typical values listed are with the slow internal reference clock (FEI) using factory trim and DMX32=0.
- The resulting system clock frequencies should not exceed their maximum specified values. The DCO frequency deviation (Δf_{dco_t}) over voltage and temperature should be considered.
- These typical values listed are with the slow internal reference clock (FEI) using factory trim and DMX32=1.
- The resulting clock frequency must not exceed the maximum specified clock frequency of the device.
- This specification applies to any time the FLL reference source or reference divider is changed, trim value is changed, DMX32 bit is changed, DRS bits are changed, or changing from FLL disabled (BLPE, BLPI) to FLL enabled (FEI, FEE, FBE, FBI). If a crystal/resonator is being used as the reference, this specification assumes it is already running.
- Excludes any oscillator currents that are also consuming power while PLL is in operation.
- This specification was obtained using a Freescale developed PCB. PLL jitter is dependent on the noise characteristics of each PCB and results will vary.
- This specification applies to any time the PLL VCO divider or reference divider is changed, or changing from PLL disabled (BLPE, BLPI) to PLL enabled (PBE, PEE). If a crystal/resonator is being used as the reference, this specification assumes it is already running.

3.3.2 IRC48M specifications

Table 14. IRC48M specifications

Symbol	Description	Min.	Typ.	Max.	Unit	Notes
V_{DD}	Supply voltage	1.71	—	3.6	V	
I_{DD48M}	Supply current	—	400	500	μ A	
f_{irc48m}	Internal reference frequency	—	48	—	MHz	
$\Delta f_{irc48m_ol_lv}$	total deviation of IRC48M frequency at low voltage (VDD=1.71V-1.89V) over temperature	—	± 0.5	± 1.5	$\%f_{irc48m}$	
$\Delta f_{irc48m_ol_hv}$	total deviation of IRC48M frequency at high voltage (VDD=1.89V-3.6V) over temperature	—	± 0.5	± 1.0	$\%f_{irc48m}$	
J_{cyc_irc48m}	Period Jitter (RMS)	—	35	150	ps	
$t_{irc48mst}$	Startup time	—	2	3	μ s	1

1. IRC48M startup time is defined as the time between clock enablement and clock availability for system use. Enable the clock by one of the following settings:
 - MCG operating in an external clocking mode and MCG_C7[OSCSSEL]=10, or
 - SIM_SOPT2[PLLFLLSEL]=11

3.3.3 Oscillator electrical specifications

3.3.3.1 Oscillator DC electrical specifications

Table 15. Oscillator DC electrical specifications

Symbol	Description	Min.	Typ.	Max.	Unit	Notes
V_{DD}	Supply voltage	1.71	—	3.6	V	
I_{DDOSC}	Supply current — low-power mode (HGO=0) <ul style="list-style-type: none"> • 32 kHz • 4 MHz • 8 MHz (RANGE=01) • 16 MHz • 24 MHz • 32 MHz 	—	500	—	nA	1
		—	200	—	μ A	
		—	300	—	μ A	
		—	950	—	μ A	
		—	1.2	—	mA	
		—	1.5	—	mA	
I_{DDOSC}	Supply current — high-gain mode (HGO=1) <ul style="list-style-type: none"> • 32 kHz • 4 MHz 	—	25	—	μ A	1
		—	400	—	μ A	

Table continues on the next page...

Table 15. Oscillator DC electrical specifications (continued)

Symbol	Description	Min.	Typ.	Max.	Unit	Notes
	<ul style="list-style-type: none"> • 8 MHz (RANGE=01) • 16 MHz • 24 MHz • 32 MHz 	—	500	—	μA	
		—	2.5	—	mA	
		—	3	—	mA	
		—	4	—	mA	
C _x	EXTAL load capacitance	—	—	—		2, 3
C _y	XTAL load capacitance	—	—	—		2, 3
R _F	Feedback resistor — low-frequency, low-power mode (HGO=0)	—	—	—	MΩ	2, 4
	Feedback resistor — low-frequency, high-gain mode (HGO=1)	—	10	—	MΩ	
	Feedback resistor — high-frequency, low-power mode (HGO=0)	—	—	—	MΩ	
	Feedback resistor — high-frequency, high-gain mode (HGO=1)	—	1	—	MΩ	
R _S	Series resistor — low-frequency, low-power mode (HGO=0)	—	—	—	kΩ	
	Series resistor — low-frequency, high-gain mode (HGO=1)	—	200	—	kΩ	
	Series resistor — high-frequency, low-power mode (HGO=0)	—	—	—	kΩ	
	Series resistor — high-frequency, high-gain mode (HGO=1)	—	0	—	kΩ	
V _{pp} ⁵	Peak-to-peak amplitude of oscillation (oscillator mode) — low-frequency, low-power mode (HGO=0)	—	0.6	—	V	
	Peak-to-peak amplitude of oscillation (oscillator mode) — low-frequency, high-gain mode (HGO=1)	—	V _{DD}	—	V	
	Peak-to-peak amplitude of oscillation (oscillator mode) — high-frequency, low-power mode (HGO=0)	—	0.6	—	V	
	Peak-to-peak amplitude of oscillation (oscillator mode) — high-frequency, high-gain mode (HGO=1)	—	V _{DD}	—	V	

1. V_{DD}=3.3 V, Temperature =25 °C
2. See crystal or resonator manufacturer's recommendation
3. C_x and C_y can be provided by using either integrated capacitors or external components.
4. When low-power mode is selected, R_F is integrated and must not be attached externally.
5. The EXTAL and XTAL pins should only be connected to required oscillator components and must not be connected to any other device.

3.3.3.2 Oscillator frequency specifications

Table 16. Oscillator frequency specifications

Symbol	Description	Min.	Typ.	Max.	Unit	Notes
f_{osc_lo}	Oscillator crystal or resonator frequency — low-frequency mode (MCG_C2[RANGE]=00)	32	—	40	kHz	
$f_{osc_hi_1}$	Oscillator crystal or resonator frequency — high-frequency mode (low range) (MCG_C2[RANGE]=01)	3	—	8	MHz	
$f_{osc_hi_2}$	Oscillator crystal or resonator frequency — high frequency mode (high range) (MCG_C2[RANGE]=1x)	8	—	32	MHz	
f_{ec_extal}	Input clock frequency (external clock mode)	—	—	50	MHz	1, 2
t_{dc_extal}	Input clock duty cycle (external clock mode)	40	50	60	%	
t_{cst}	Crystal startup time — 32 kHz low-frequency, low-power mode (HGO=0)	—	750	—	ms	3, 4
	Crystal startup time — 32 kHz low-frequency, high-gain mode (HGO=1)	—	250	—	ms	
	Crystal startup time — 8 MHz high-frequency (MCG_C2[RANGE]=01), low-power mode (HGO=0)	—	0.6	—	ms	
	Crystal startup time — 8 MHz high-frequency (MCG_C2[RANGE]=01), high-gain mode (HGO=1)	—	1	—	ms	

1. Other frequency limits may apply when external clock is being used as a reference for the FLL or PLL.
2. When transitioning from FEI or FBI to FBE mode, restrict the frequency of the input clock so that, when it is divided by FRDIV, it remains within the limits of the DCO input clock frequency.
3. Proper PC board layout procedures must be followed to achieve specifications.
4. Crystal startup time is defined as the time between the oscillator being enabled and the OSCINIT bit in the MCG_S register being set.

3.4 Memories and memory interfaces

3.4.1 Flash electrical specifications

This section describes the electrical characteristics of the flash memory module.

3.4.1.1 Flash timing specifications — program and erase

The following specifications represent the amount of time the internal charge pumps are active and do not include command overhead.

Table 17. NVM program/erase timing specifications

Symbol	Description	Min.	Typ.	Max.	Unit	Notes
t _{hvp_{gm4}}	Longword Program high-voltage time	—	7.5	18	μs	—
t _{hversscr}	Sector Erase high-voltage time	—	13	113	ms	1
t _{hversall}	Erase All high-voltage time	—	52	452	ms	1

1. Maximum time based on expectations at cycling end-of-life.

3.4.1.2 Flash timing specifications — commands

Table 18. Flash command timing specifications

Symbol	Description	Min.	Typ.	Max.	Unit	Notes
t _{rd1sec2k}	Read 1s Section execution time (flash sector)	—	—	60	μs	1
t _{pgmchk}	Program Check execution time	—	—	45	μs	1
t _{rdsrc}	Read Resource execution time	—	—	30	μs	1
t _{pgm4}	Program Longword execution time	—	65	145	μs	—
t _{ersscr}	Erase Flash Sector execution time	—	14	114	ms	2
t _{rd1all}	Read 1s All Blocks execution time	—	—	1.8	ms	—
t _{rdonce}	Read Once execution time	—	—	30	μs	1
t _{pgmonce}	Program Once execution time	—	100	—	μs	—
t _{ersall}	Erase All Blocks execution time	—	175	1300	ms	2
t _{vfykey}	Verify Backdoor Access Key execution time	—	—	30	μs	1

1. Assumes 25 MHz flash clock frequency.
2. Maximum times for erase parameters based on expectations at cycling end-of-life.

3.4.1.3 Flash high voltage current behaviors

Table 19. Flash high voltage current behaviors

Symbol	Description	Min.	Typ.	Max.	Unit
I _{DD_PGM}	Average current adder during high voltage flash programming operation	—	2.5	6.0	mA
I _{DD_ERS}	Average current adder during high voltage flash erase operation	—	1.5	4.0	mA

3.4.1.4 Reliability specifications

Table 20. NVM reliability specifications

Symbol	Description	Min.	Typ. ¹	Max.	Unit	Notes
Program Flash						

Table continues on the next page...

Table 20. NVM reliability specifications (continued)

Symbol	Description	Min.	Typ. ¹	Max.	Unit	Notes
$t_{nvmretp10k}$	Data retention after up to 10 K cycles	5	50	—	years	—
$t_{nvmretp1k}$	Data retention after up to 1 K cycles	20	100	—	years	—
$n_{nvmcycp}$	Cycling endurance	10 K	50 K	—	cycles	2

1. Typical data retention values are based on measured response accelerated at high temperature and derated to a constant 25 °C use profile. Engineering Bulletin EB618 does not apply to this technology. Typical endurance defined in Engineering Bulletin EB619.
2. Cycling endurance represents number of program/erase cycles at $-40\text{ °C} \leq T_j \leq 125\text{ °C}$.

3.4.2 EzPort switching specifications

Table 21. EzPort switching specifications

Num	Description	Min.	Max.	Unit
	Operating voltage	1.71	3.6	V
EP1	EZP_CK frequency of operation (all commands except READ)	—	$f_{SYS}/2$	MHz
EP1a	EZP_CK frequency of operation (READ command)	—	$f_{SYS}/8$	MHz
EP2	$\overline{\text{EZP_CS}}$ negation to next $\overline{\text{EZP_CS}}$ assertion	$2 \times t_{\text{EZP_CK}}$	—	ns
EP3	$\overline{\text{EZP_CS}}$ input valid to EZP_CK high (setup)	5	—	ns
EP4	EZP_CK high to $\overline{\text{EZP_CS}}$ input invalid (hold)	5	—	ns
EP5	EZP_D input valid to EZP_CK high (setup)	2	—	ns
EP6	EZP_CK high to EZP_D input invalid (hold)	5	—	ns
EP7	EZP_CK low to EZP_Q output valid	—	25	ns
EP8	EZP_CK low to EZP_Q output invalid (hold)	0	—	ns
EP9	$\overline{\text{EZP_CS}}$ negation to EZP_Q tri-state	—	12	ns

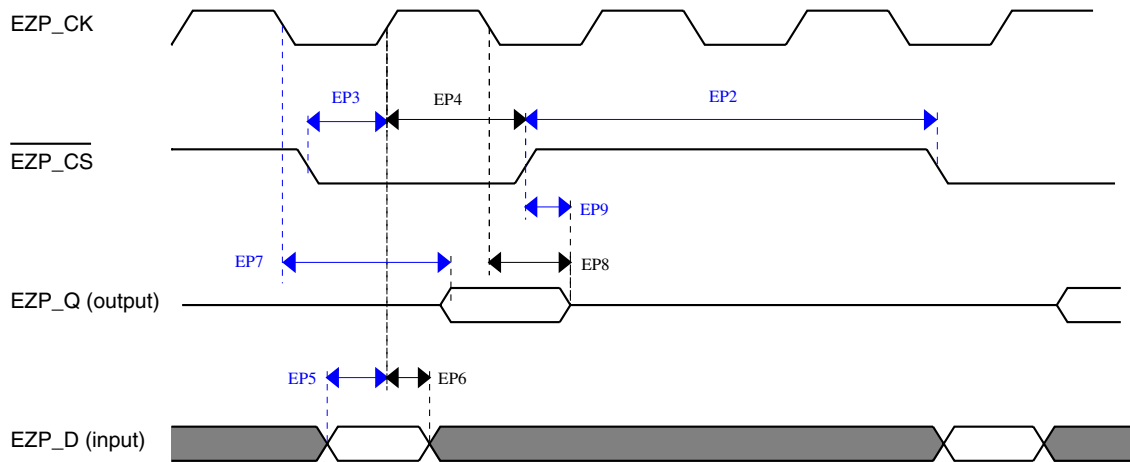

Figure 11. EzPort Timing Diagram

3.5 Security and integrity modules

There are no specifications necessary for the device's security and integrity modules.

3.6 Analog

3.6.1 ADC electrical specifications

The 16-bit accuracy specifications listed in [Table 22](#) and [Table 23](#) are achievable on the differential pins ADCx_DPx, ADCx_DMx.

All other ADC channels meet the 13-bit differential/12-bit single-ended accuracy specifications.

3.6.1.1 16-bit ADC operating conditions

Table 22. 16-bit ADC operating conditions

Symbol	Description	Conditions	Min.	Typ. ¹	Max.	Unit	Notes
V _{DDA}	Supply voltage	Absolute	1.71	—	3.6	V	
ΔV _{DDA}	Supply voltage	Delta to V _{DD} (V _{DD} – V _{DDA})	-100	0	+100	mV	2

Table continues on the next page...

Table 22. 16-bit ADC operating conditions (continued)

Symbol	Description	Conditions	Min.	Typ. ¹	Max.	Unit	Notes
ΔV_{SSA}	Ground voltage	Delta to V_{SS} ($V_{SS} - V_{SSA}$)	-100	0	+100	mV	2
V_{REFH}	ADC reference voltage high		1.13	V_{DDA}	V_{DDA}	V	
V_{REFL}	ADC reference voltage low		V_{SSA}	V_{SSA}	V_{SSA}	V	
V_{ADIN}	Input voltage	<ul style="list-style-type: none"> 16-bit differential mode All other modes 	V_{REFL} V_{REFL}	— —	31/32 * V_{REFH} V_{REFH}	V	
C_{ADIN}	Input capacitance	<ul style="list-style-type: none"> 16-bit mode 8-bit / 10-bit / 12-bit modes 	— —	8 4	10 5	pF	
R_{ADIN}	Input series resistance		—	2	5	k Ω	
R_{AS}	Analog source resistance (external)	13-bit / 12-bit modes $f_{ADCK} < 4$ MHz	—	—	5	k Ω	3
f_{ADCK}	ADC conversion clock frequency	\leq 13-bit mode	1.0	—	24.0	MHz	4
f_{ADCK}	ADC conversion clock frequency	16-bit mode	2.0	—	12.0	MHz	4
C_{rate}	ADC conversion rate	\leq 13-bit modes No ADC hardware averaging Continuous conversions enabled, subsequent conversion time	20	—	1200	Ksps	5
C_{rate}	ADC conversion rate	16-bit mode No ADC hardware averaging Continuous conversions enabled, subsequent conversion time	37	—	461	Ksps	5

1. Typical values assume $V_{DDA} = 3.0$ V, Temp = 25 °C, $f_{ADCK} = 1.0$ MHz, unless otherwise stated. Typical values are for reference only, and are not tested in production.
2. DC potential difference.
3. This resistance is external to MCU. To achieve the best results, the analog source resistance must be kept as low as possible. The results in this data sheet were derived from a system that had $< 8 \Omega$ analog source resistance. The R_{AS}/C_{AS} time constant should be kept to < 1 ns.
4. To use the maximum ADC conversion clock frequency, CFG2[ADHSC] must be set and CFG1[ADLPC] must be clear.
5. For guidelines and examples of conversion rate calculation, download the [ADC calculator tool](#).

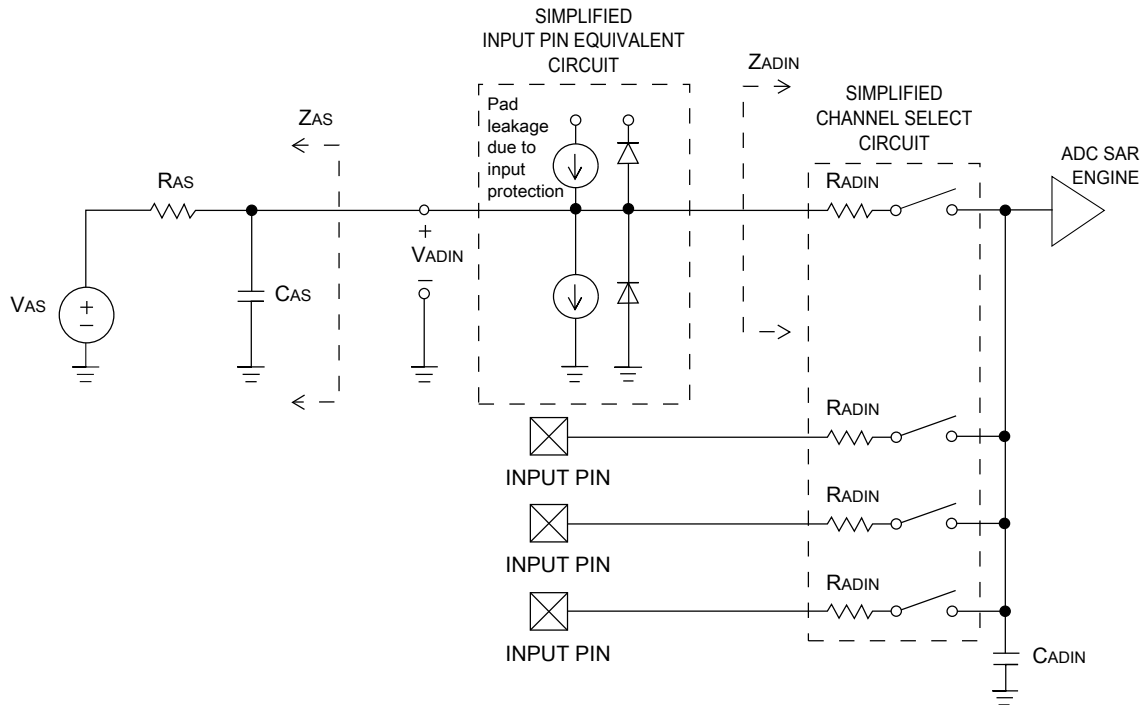

Figure 12. ADC input impedance equivalency diagram

3.6.1.2 16-bit ADC electrical characteristics

Table 23. 16-bit ADC characteristics ($V_{REFH} = V_{DDA}$, $V_{REFL} = V_{SSA}$)

Symbol	Description	Conditions ¹	Min.	Typ. ²	Max.	Unit	Notes
I_{DDA_ADC}	Supply current		0.215	—	1.7	mA	3
f_{ADACK}	ADC asynchronous clock source	• ADLPC = 1, ADHSC = 0	1.2	2.4	3.9	MHz	$t_{ADACK} = 1/f_{ADACK}$
		• ADLPC = 1, ADHSC = 1	2.4	4.0	6.1	MHz	
		• ADLPC = 0, ADHSC = 0	3.0	5.2	7.3	MHz	
		• ADLPC = 0, ADHSC = 1	4.4	6.2	9.5	MHz	
	Sample Time	See Reference Manual chapter for sample times					
TUE	Total unadjusted error	• 12-bit modes • <12-bit modes	—	±4 ±1.4	±6.8 ±2.1	LSB ⁴	5
DNL	Differential non-linearity	• 12-bit modes • <12-bit modes	—	±0.7 ±0.2	-1.1 to +1.9 -0.3 to 0.5	LSB ⁴	5

Table continues on the next page...

Table 23. 16-bit ADC characteristics ($V_{REFH} = V_{DDA}$, $V_{REFL} = V_{SSA}$) (continued)

Symbol	Description	Conditions ¹	Min.	Typ. ²	Max.	Unit	Notes
INL	Integral non-linearity	<ul style="list-style-type: none"> 12-bit modes <12-bit modes 	—	±1.0	-2.7 to +1.9	LSB ⁴	5
E_{FS}	Full-scale error	<ul style="list-style-type: none"> 12-bit modes <12-bit modes 	—	-4	-5.4	LSB ⁴	$V_{ADIN} = V_{DDA}$ ⁵
E_Q	Quantization error	<ul style="list-style-type: none"> 16-bit modes ≤13-bit modes 	—	-1 to 0	—	LSB ⁴	
ENOB	Effective number of bits	16-bit differential mode <ul style="list-style-type: none"> Avg = 32 Avg = 4 16-bit single-ended mode <ul style="list-style-type: none"> Avg = 32 Avg = 4 	12.8 11.9 12.2 11.4	14.5 13.8 13.9 13.1	— — — —	bits bits bits bits	6
SINAD	Signal-to-noise plus distortion	See ENOB	6.02 × ENOB + 1.76			dB	
THD	Total harmonic distortion	16-bit differential mode <ul style="list-style-type: none"> Avg = 32 16-bit single-ended mode <ul style="list-style-type: none"> Avg = 32 	— —	-94 -85	— —	dB dB	7
SFDR	Spurious free dynamic range	16-bit differential mode <ul style="list-style-type: none"> Avg = 32 16-bit single-ended mode <ul style="list-style-type: none"> Avg = 32 	82 78	95 90	— —	dB dB	7
E_{IL}	Input leakage error		$I_{in} \times R_{AS}$			mV	I_{in} = leakage current (refer to the MCU's voltage and current operating ratings)
	Temp sensor slope	Across the full temperature range of the device	1.55	1.62	1.69	mV/°C	8
V_{TEMP25}	Temp sensor voltage	25 °C	706	716	726	mV	8

1. All accuracy numbers assume the ADC is calibrated with $V_{REFH} = V_{DDA}$
2. Typical values assume $V_{DDA} = 3.0\text{ V}$, $\text{Temp} = 25\text{ }^{\circ}\text{C}$, $f_{ADCK} = 2.0\text{ MHz}$ unless otherwise stated. Typical values are for reference only and are not tested in production.
3. The ADC supply current depends on the ADC conversion clock speed, conversion rate and ADC_CFG1[ADLPC] (low power). For lowest power operation, ADC_CFG1[ADLPC] must be set, the ADC_CFG2[ADHSC] bit must be clear with 1 MHz ADC conversion clock speed.
4. $1\text{ LSB} = (V_{REFH} - V_{REFL})/2^N$
5. ADC conversion clock < 16 MHz, Max hardware averaging (AVGE = %1, AVGS = %11)
6. Input data is 100 Hz sine wave. ADC conversion clock < 12 MHz.
7. Input data is 1 kHz sine wave. ADC conversion clock < 12 MHz.
8. ADC conversion clock < 3 MHz

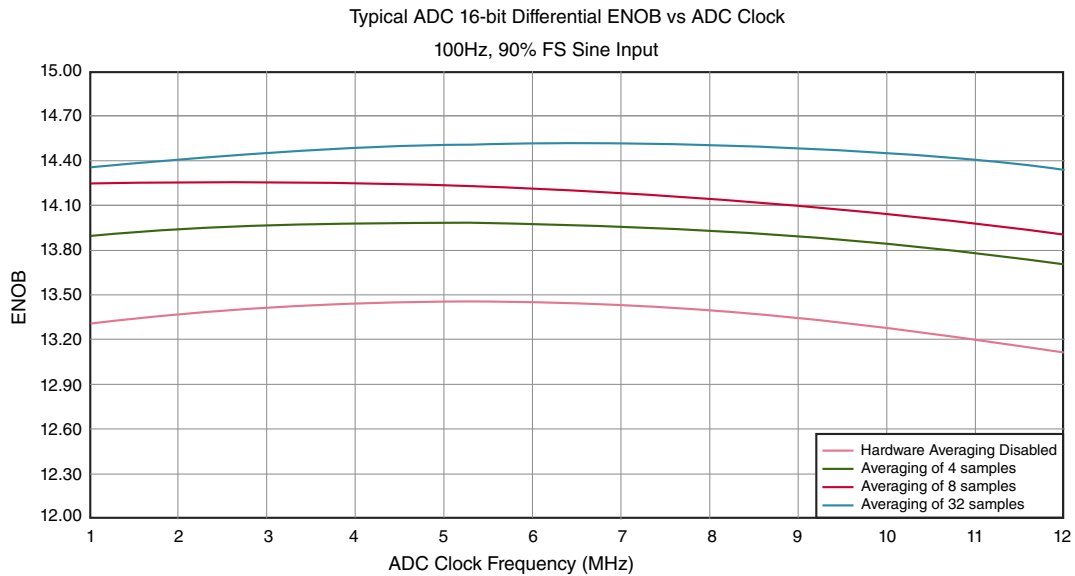

Figure 13. Typical ENOB vs. ADC_CLK for 16-bit differential mode

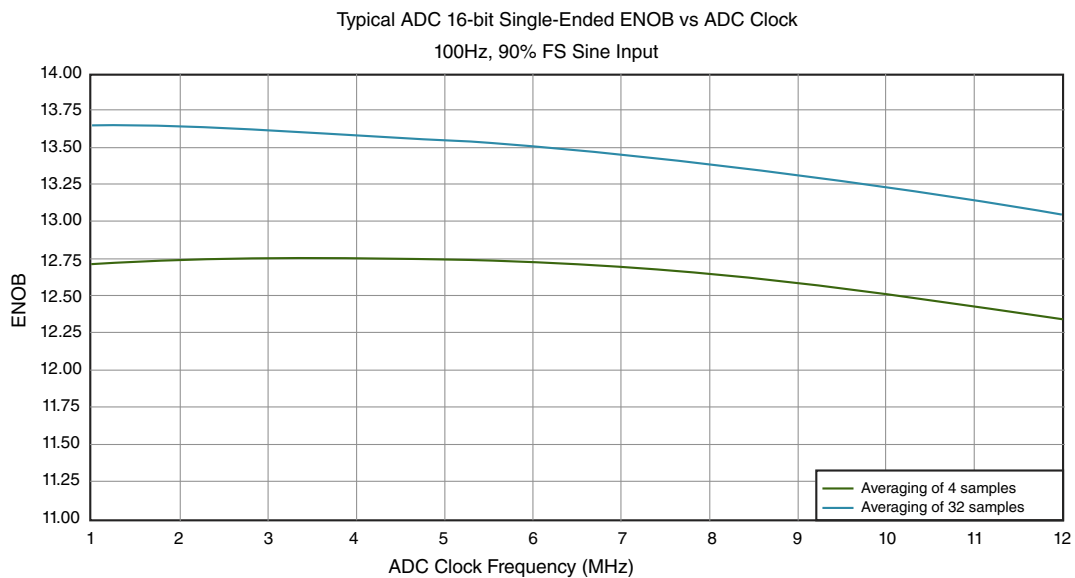

Figure 14. Typical ENOB vs. ADC_CLK for 16-bit single-ended mode

3.6.2 CMP and 6-bit DAC electrical specifications

Table 24. Comparator and 6-bit DAC electrical specifications

Symbol	Description	Min.	Typ.	Max.	Unit
V_{DD}	Supply voltage	1.71	—	3.6	V
I_{DDHS}	Supply current, High-speed mode (EN=1, PMODE=1)	—	—	200	μ A
I_{DLS}	Supply current, low-speed mode (EN=1, PMODE=0)	—	—	20	μ A
V_{AIN}	Analog input voltage	$V_{SS} - 0.3$	—	V_{DD}	V
V_{AIO}	Analog input offset voltage	—	—	20	mV
V_H	Analog comparator hysteresis ¹				
	• CR0[HYSTCTR] = 00	—	5	—	mV
	• CR0[HYSTCTR] = 01	—	10	—	mV
	• CR0[HYSTCTR] = 10	—	20	—	mV
	• CR0[HYSTCTR] = 11	—	30	—	mV
V_{CMPOh}	Output high	$V_{DD} - 0.5$	—	—	V
V_{CMPOl}	Output low	—	—	0.5	V
t_{DHS}	Propagation delay, high-speed mode (EN=1, PMODE=1)	20	50	200	ns
t_{DLS}	Propagation delay, low-speed mode (EN=1, PMODE=0)	80	250	600	ns
	Analog comparator initialization delay ²	—	—	40	μ s
I_{DAC6b}	6-bit DAC current adder (enabled)	—	7	—	μ A
INL	6-bit DAC integral non-linearity	-0.5	—	0.5	LSB ³
DNL	6-bit DAC differential non-linearity	-0.3	—	0.3	LSB

1. Typical hysteresis is measured with input voltage range limited to 0.6 to $V_{DD}-0.6$ V.
2. Comparator initialization delay is defined as the time between software writes to change control inputs (Writes to CMP_DACCR[DACEN], CMP_DACCR[VRSEL], CMP_DACCR[VOSEL], CMP_MUXCR[PSEL], and CMP_MUXCR[MSEL]) and the comparator output settling to a stable level.
3. 1 LSB = $V_{reference}/64$

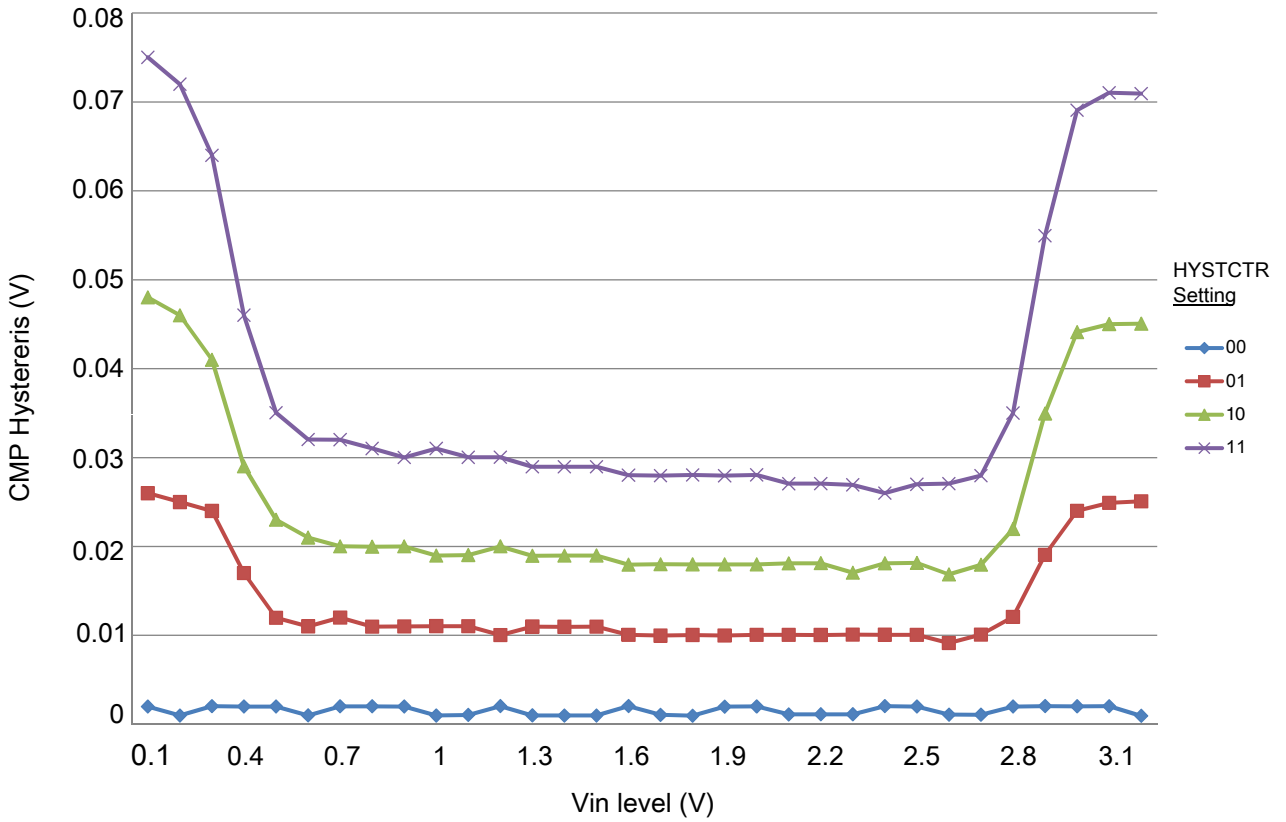

Figure 15. Typical hysteresis vs. Vin level (VDD = 3.3 V, PMODE = 0)

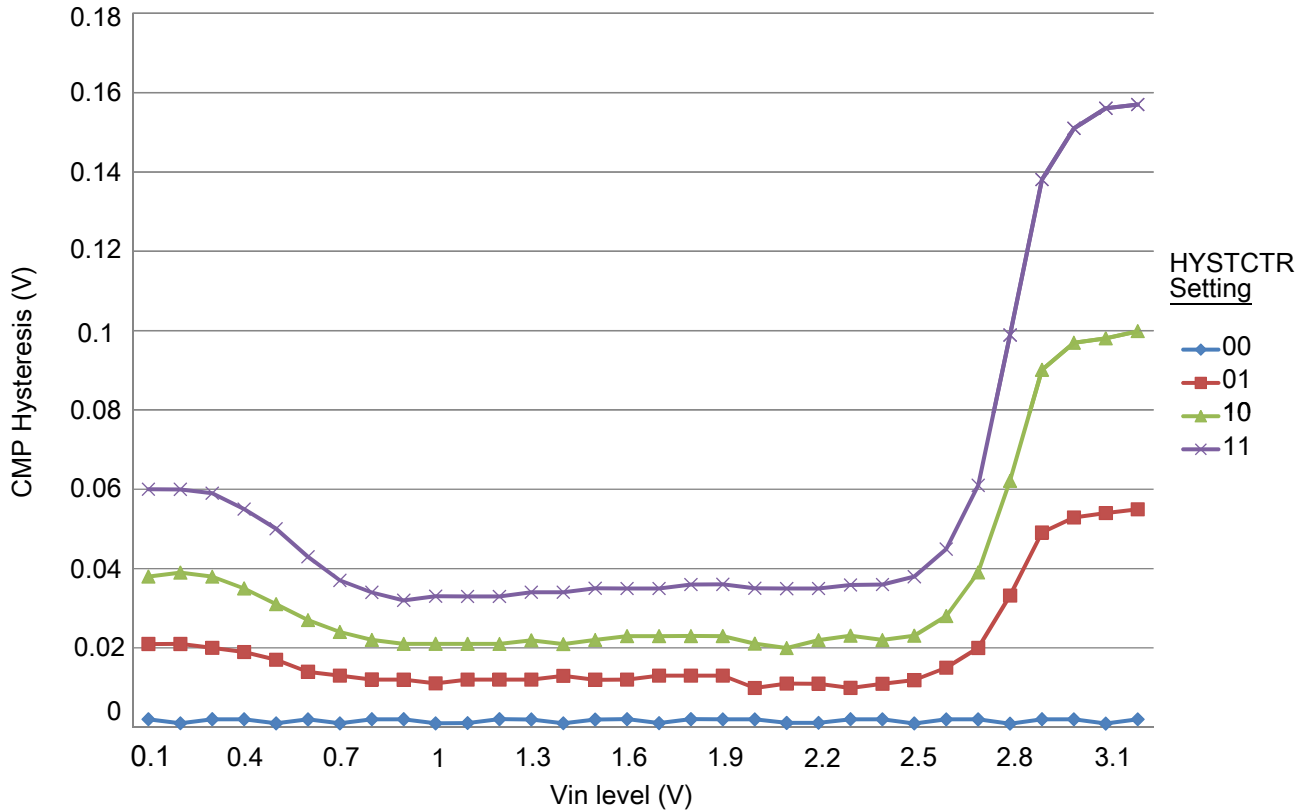

Figure 16. Typical hysteresis vs. Vin level (VDD = 3.3 V, PMODE = 1)

3.6.3 12-bit DAC electrical characteristics

3.6.3.1 12-bit DAC operating requirements

Table 25. 12-bit DAC operating requirements

Symbol	Description	Min.	Max.	Unit	Notes
V_{DDA}	Supply voltage	1.71	3.6	V	
V_{DACR}	Reference voltage	1.13	3.6	V	1
C_L	Output load capacitance	—	100	pF	2
I_L	Output load current	—	1	mA	

1. The DAC reference can be selected to be V_{DDA} or V_{REFH} .
2. A small load capacitance (47 pF) can improve the bandwidth performance of the DAC.

3.6.3.2 12-bit DAC operating behaviors

Table 26. 12-bit DAC operating behaviors

Symbol	Description	Min.	Typ.	Max.	Unit	Notes
I_{DDA_DACLP}	Supply current — low-power mode	—	—	330	μA	
I_{DDA_DACHP}	Supply current — high-speed mode	—	—	1200	μA	
t_{DACLP}	Full-scale settling time (0x080 to 0xF7F) — low-power mode	—	100	200	μs	1
t_{DACHP}	Full-scale settling time (0x080 to 0xF7F) — high-power mode	—	15	30	μs	1
$t_{CCDACLP}$	Code-to-code settling time (0xBF8 to 0xC08) — low-power mode and high-speed mode	—	0.7	1	μs	1
$V_{dacoutl}$	DAC output voltage range low — high-speed mode, no load, DAC set to 0x000	—	—	100	mV	
$V_{dacouth}$	DAC output voltage range high — high-speed mode, no load, DAC set to 0xFFFF	$V_{DACR} - 100$	—	V_{DACR}	mV	
INL	Integral non-linearity error — high speed mode	—	—	± 8	LSB	2
DNL	Differential non-linearity error — $V_{DACR} > 2\text{ V}$	—	—	± 1	LSB	3
DNL	Differential non-linearity error — $V_{DACR} = V_{REF_OUT}$	—	—	± 1	LSB	4
V_{OFFSET}	Offset error	—	± 0.4	± 0.8	%FSR	5
E_G	Gain error	—	± 0.1	± 0.6	%FSR	5
PSRR	Power supply rejection ratio, $V_{DDA} \geq 2.4\text{ V}$	60	—	90	dB	
T_{CO}	Temperature coefficient offset voltage	—	3.7	—	$\mu\text{V}/\text{C}$	6
T_{GE}	Temperature coefficient gain error	—	0.000421	—	%FSR/C	
R_{op}	Output resistance (load = 3 k Ω)	—	—	250	Ω	
SR	Slew rate -80h → F7Fh → 80h <ul style="list-style-type: none"> High power (SP_{HP}) Low power (SP_{LP}) 	1.2 0.05	1.7 0.12	— —	$\text{V}/\mu\text{s}$	
BW	3dB bandwidth <ul style="list-style-type: none"> High power (SP_{HP}) Low power (SP_{LP}) 	550 40	— —	— —	kHz	

- Settling within ± 1 LSB
- The INL is measured for 0 + 100 mV to $V_{DACR} - 100$ mV
- The DNL is measured for 0 + 100 mV to $V_{DACR} - 100$ mV
- The DNL is measured for 0 + 100 mV to $V_{DACR} - 100$ mV with $V_{DDA} > 2.4\text{ V}$
- Calculated by a best fit curve from $V_{SS} + 100$ mV to $V_{DACR} - 100$ mV
- $V_{DDA} = 3.0\text{ V}$, reference select set for V_{DDA} ($DACx_CO:DACRFS = 1$), high power mode ($DACx_CO:LPEN = 0$), DAC set to 0x800, temperature range is across the full range of the device

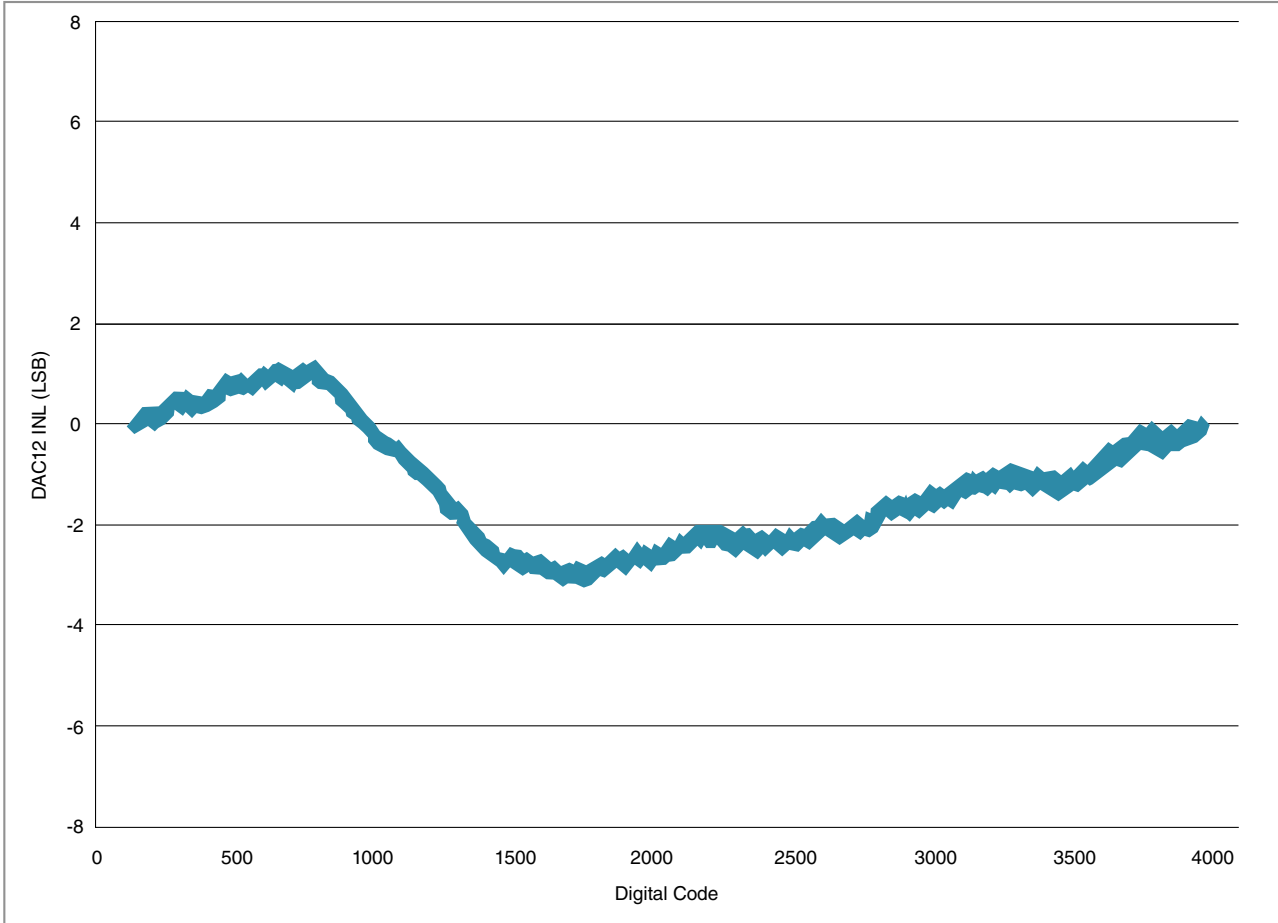

Figure 17. Typical INL error vs. digital code

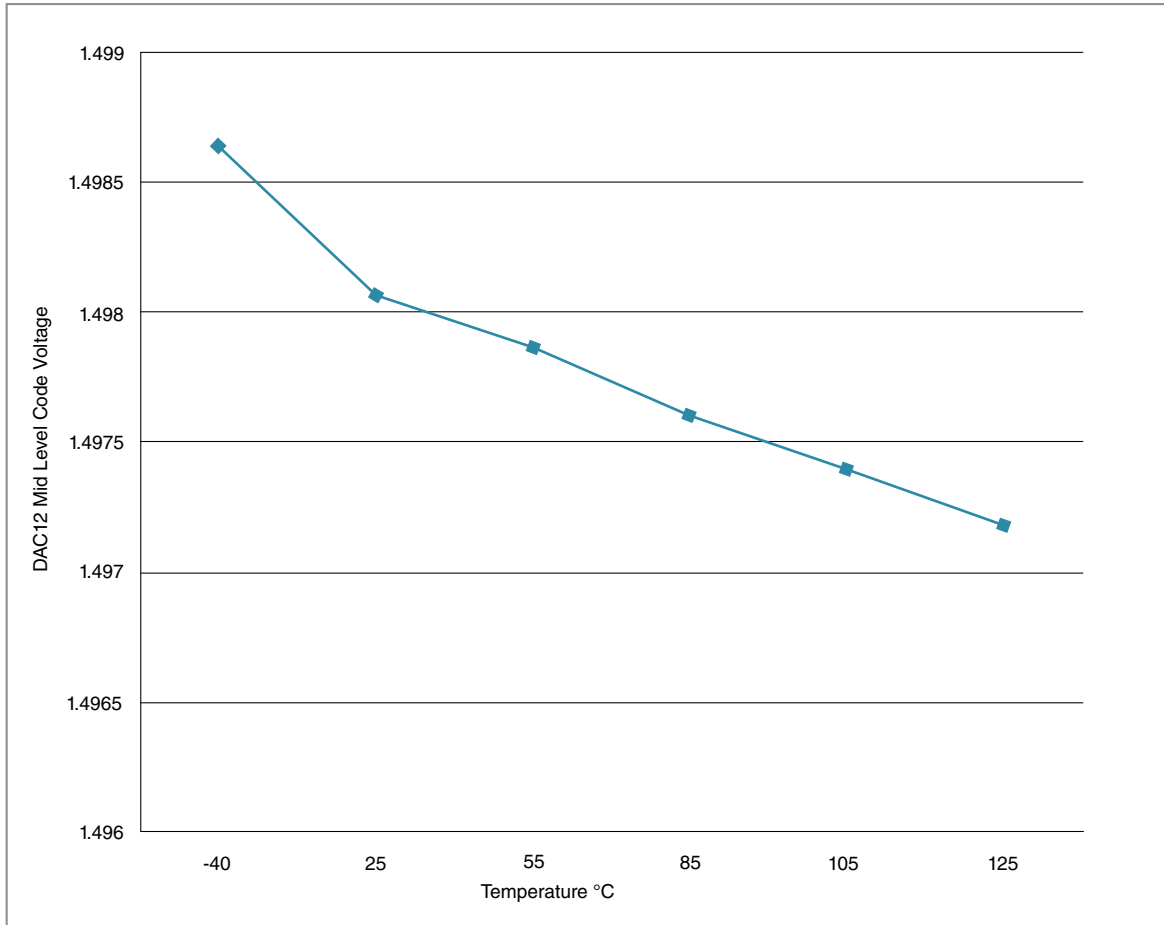

Figure 18. Offset at half scale vs. temperature

3.6.4 Voltage reference electrical specifications

Table 27. VREF full-range operating requirements

Symbol	Description	Min.	Max.	Unit	Notes
V_{DDA}	Supply voltage	1.71	3.6	V	
T_A	Temperature	Operating temperature range of the device		°C	
C_L	Output load capacitance	100		nF	1, 2

- C_L must be connected to VREF_OUT if the VREF_OUT functionality is being used for either an internal or external reference.
- The load capacitance should not exceed +/-25% of the nominal specified C_L value over the operating temperature range of the device.

Table 28. VREF full-range operating behaviors

Symbol	Description	Min.	Typ.	Max.	Unit	Notes
V_{out}	Voltage reference output with factory trim at nominal V_{DDA} and temperature=25°C	1.1920	1.1950	1.1980	V	1
V_{out}	Voltage reference output with user trim at nominal V_{DDA} and temperature=25°C	1.1945	1.1950	1.1955	V	1
V_{step}	Voltage reference trim step	—	0.5	—	mV	1
V_{tdrift}	Temperature drift ($V_{max} - V_{min}$ across the full temperature range)	—	—	15	mV	1
I_{bg}	Bandgap only current	—	—	80	μ A	
I_{lp}	Low-power buffer current	—	—	360	μ A	1
I_{hp}	High-power buffer current	—	—	1	mA	1
ΔV_{LOAD}	Load regulation • current = ± 1.0 mA	—	200	—	μ V	1, 2
T_{stup}	Buffer startup time	—	—	100	μ s	
$T_{chop_osc_st\ up}$	Internal bandgap start-up delay with chop oscillator enabled	—	—	35	ms	
V_{vdrift}	Voltage drift ($V_{max} - V_{min}$ across the full voltage range)	—	2	—	mV	1

1. See the chip's Reference Manual for the appropriate settings of the VREF Status and Control register.
2. Load regulation voltage is the difference between the VREF_OUT voltage with no load vs. voltage with defined load

Table 29. VREF limited-range operating requirements

Symbol	Description	Min.	Max.	Unit	Notes
T_A	Temperature	0	70	°C	

Table 30. VREF limited-range operating behaviors

Symbol	Description	Min.	Max.	Unit	Notes
V_{tdrift}	Temperature drift ($V_{max} - V_{min}$ across the limited temperature range)	—	10	mV	

3.7 Timers

See [General switching specifications](#).

3.8 Communication interfaces

3.8.1 DSPI switching specifications (limited voltage range)

The Deserial Serial Peripheral Interface (DSPI) provides a synchronous serial bus with master and slave operations. Many of the transfer attributes are programmable. The tables below provide DSPI timing characteristics for classic SPI timing modes. Refer to the SPI chapter of the Reference Manual for information on the modified transfer formats used for communicating with slower peripheral devices.

Table 31. Master mode DSPI timing (limited voltage range)

Num	Description	Min.	Max.	Unit	Notes
	Operating voltage	2.7	3.6	V	
	Frequency of operation	—	30	MHz	
DS1	DSPI_SCK output cycle time	$2 \times t_{\text{BUS}}$	—	ns	
DS2	DSPI_SCK output high/low time	$(t_{\text{SCK}}/2) - 2$	$(t_{\text{SCK}}/2) + 2$	ns	
DS3	DSPI_PCSn valid to DSPI_SCK delay	$(t_{\text{BUS}} \times 2) - 2$	—	ns	1
DS4	DSPI_SCK to DSPI_PCSn invalid delay	$(t_{\text{BUS}} \times 2) - 2$	—	ns	2
DS5	DSPI_SCK to DSPI_SOUT valid	—	8.5	ns	
DS6	DSPI_SCK to DSPI_SOUT invalid	-2	—	ns	
DS7	DSPI_SIN to DSPI_SCK input setup	16.2	—	ns	
DS8	DSPI_SCK to DSPI_SIN input hold	0	—	ns	

1. The delay is programmable in SPIx_CTARn[PSSCK] and SPIx_CTARn[CSSCK].
2. The delay is programmable in SPIx_CTARn[PASC] and SPIx_CTARn[ASC].

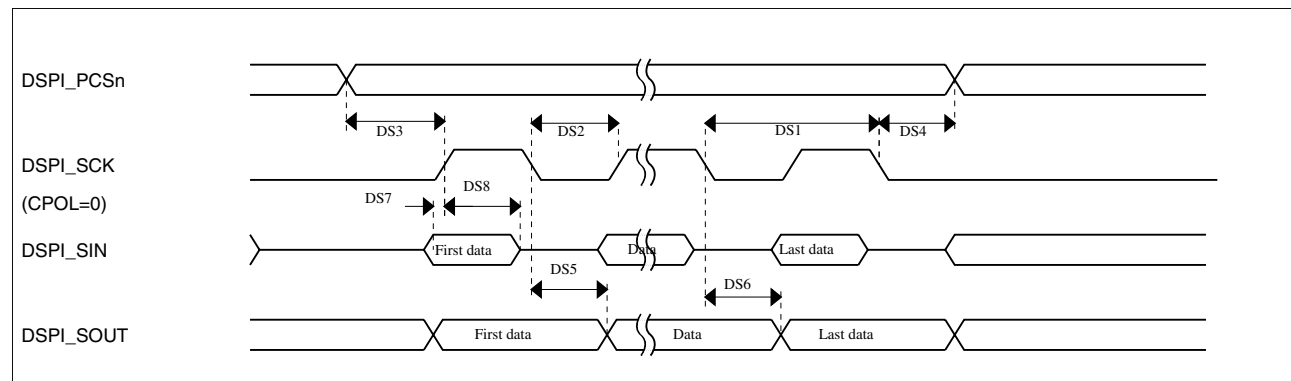

Figure 19. DSPI classic SPI timing — master mode

Table 32. Slave mode DSPI timing (limited voltage range)

Num	Description	Min.	Max.	Unit
	Operating voltage	2.7	3.6	V
	Frequency of operation	—	15	MHz
DS9	DSPI_SCK input cycle time	$4 \times t_{BUS}$	—	ns
DS10	DSPI_SCK input high/low time	$(t_{SCK}/2) - 2$	$(t_{SCK}/2) + 2$	ns
DS11	DSPI_SCK to DSPI_SOUT valid	—	21.4	ns
DS12	DSPI_SCK to DSPI_SOUT invalid	0	—	ns
DS13	DSPI_SIN to DSPI_SCK input setup	2.6	—	ns
DS14	DSPI_SCK to DSPI_SIN input hold	7	—	ns
DS15	DSPI_SS active to DSPI_SOUT driven	—	17	ns
DS16	DSPI_SS inactive to DSPI_SOUT not driven	—	17	ns

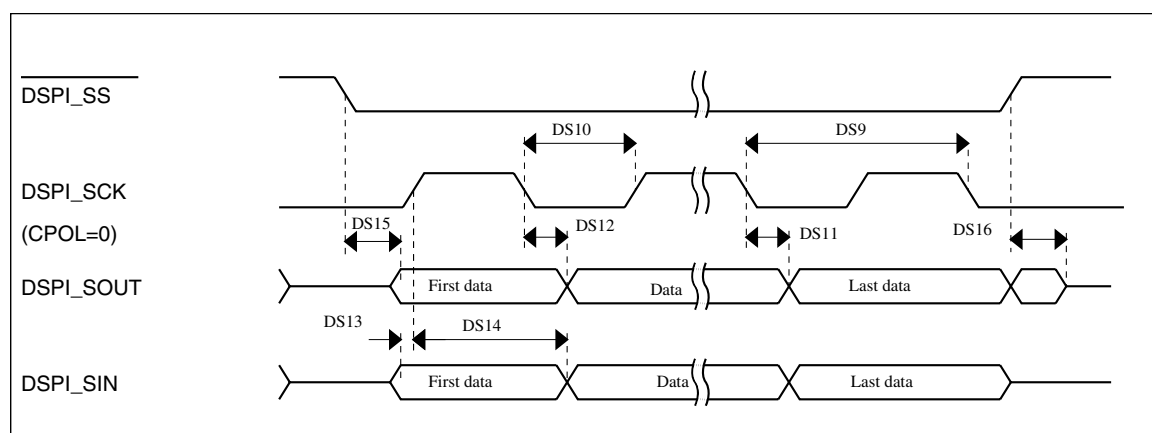

Figure 20. DSPI classic SPI timing — slave mode

3.8.2 DSPI switching specifications (full voltage range)

The Deserial Serial Peripheral Interface (DSPI) provides a synchronous serial bus with master and slave operations. Many of the transfer attributes are programmable. The tables below provides DSPI timing characteristics for classic SPI timing modes. Refer to the SPI chapter of the Reference Manual for information on the modified transfer formats used for communicating with slower peripheral devices.

Table 33. Master mode DSPI timing (full voltage range)

Num	Description	Min.	Max.	Unit	Notes
	Operating voltage	1.71	3.6	V	1
	Frequency of operation	—	15	MHz	

Table continues on the next page...

Table 33. Master mode DSPI timing (full voltage range) (continued)

Num	Description	Min.	Max.	Unit	Notes
DS1	DSPI_SCK output cycle time	$4 \times t_{\text{BUS}}$	—	ns	
DS2	DSPI_SCK output high/low time	$(t_{\text{SCK}/2}) - 4$	$(t_{\text{SCK}/2}) + 4$	ns	
DS3	DSPI_PCSn valid to DSPI_SCK delay	$(t_{\text{BUS}} \times 2) - 4$	—	ns	2
DS4	DSPI_SCK to DSPI_PCSn invalid delay	$(t_{\text{BUS}} \times 2) - 4$	—	ns	3
DS5	DSPI_SCK to DSPI_SOUT valid	—	10	ns	
DS6	DSPI_SCK to DSPI_SOUT invalid	-4.5	—	ns	
DS7	DSPI_SIN to DSPI_SCK input setup	24.6	—	ns	
DS8	DSPI_SCK to DSPI_SIN input hold	0	—	ns	

1. The DSPI module can operate across the entire operating voltage for the processor, but to run across the full voltage range the maximum frequency of operation is reduced.
2. The delay is programmable in SPIx_CTARn[PSSCK] and SPIx_CTARn[CSSCK].
3. The delay is programmable in SPIx_CTARn[PASC] and SPIx_CTARn[ASC].

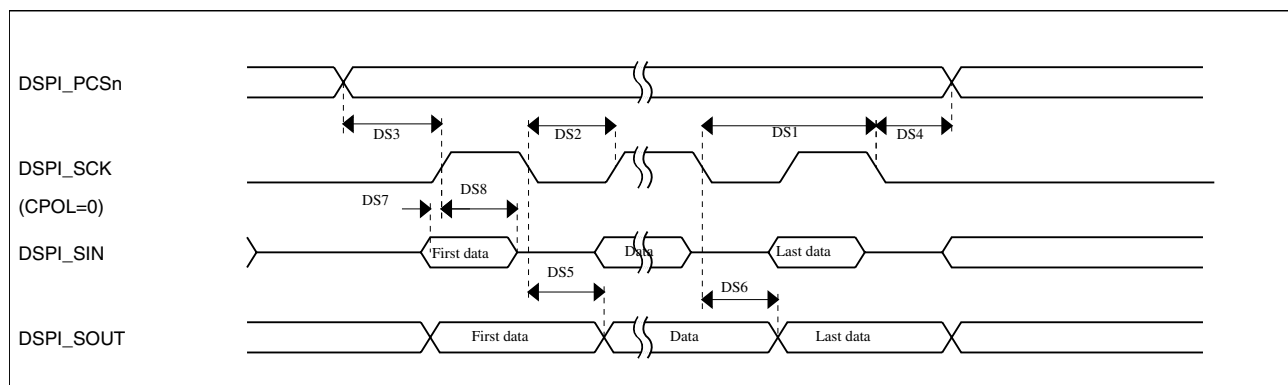
**Figure 21. DSPI classic SPI timing — master mode****Table 34. Slave mode DSPI timing (full voltage range)**

Num	Description	Min.	Max.	Unit
	Operating voltage	1.71	3.6	V
	Frequency of operation	—	7.5	MHz
DS9	DSPI_SCK input cycle time	$8 \times t_{\text{BUS}}$	—	ns
DS10	DSPI_SCK input high/low time	$(t_{\text{SCK}/2}) - 4$	$(t_{\text{SCK}/2}) + 4$	ns
DS11	DSPI_SCK to DSPI_SOUT valid	—	29.5	ns
DS12	DSPI_SCK to DSPI_SOUT invalid	0	—	ns
DS13	DSPI_SIN to DSPI_SCK input setup	3.2	—	ns
DS14	DSPI_SCK to DSPI_SIN input hold	7	—	ns
DS15	$\overline{\text{DSPI_SS}}$ active to DSPI_SOUT driven	—	25	ns
DS16	$\overline{\text{DSPI_SS}}$ inactive to DSPI_SOUT not driven	—	25	ns

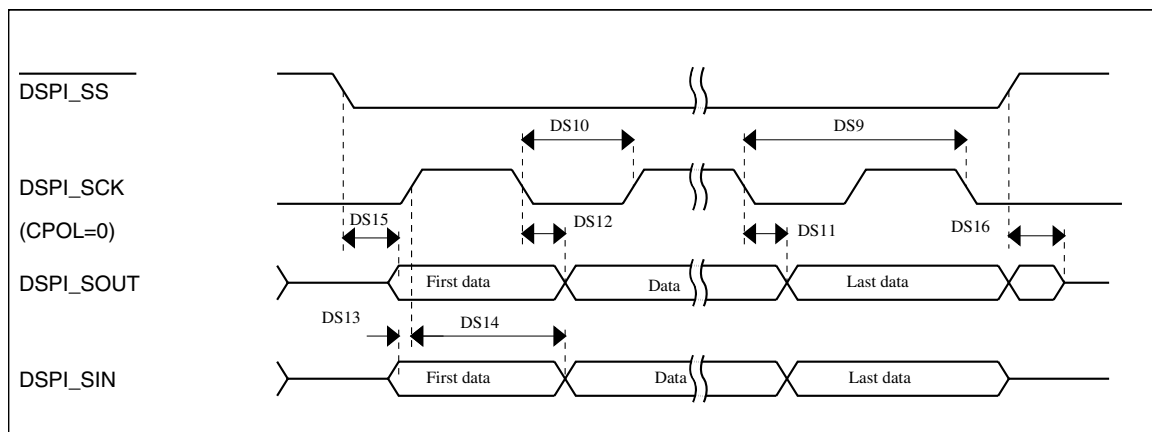

Figure 22. DSPI classic SPI timing — slave mode

3.8.3 Inter-Integrated Circuit Interface (I²C) timing

Table 35. I²C timing

Characteristic	Symbol	Standard Mode		Fast Mode		Unit
		Minimum	Maximum	Minimum	Maximum	
SCL Clock Frequency	f_{SCL}	0	100	0	400	kHz
Hold time (repeated) START condition. After this period, the first clock pulse is generated.	$t_{HD}; STA$	4	—	0.6	—	μs
LOW period of the SCL clock	t_{LOW}	4.7	—	1.3	—	μs
HIGH period of the SCL clock	t_{HIGH}	4	—	0.6	—	μs
Set-up time for a repeated START condition	$t_{SU}; STA$	4.7	—	0.6	—	μs
Data hold time for I ² C bus devices	$t_{HD}; DAT$	0 ¹	3.45 ²	0 ³	0.9 ¹	μs
Data set-up time	$t_{SU}; DAT$	250 ⁴	—	100 ^{2, 5}	—	ns
Rise time of SDA and SCL signals	t_r	—	1000	$20 + 0.1C_b$ ⁶	300	ns
Fall time of SDA and SCL signals	t_f	—	300	$20 + 0.1C_b$ ⁵	300	ns
Set-up time for STOP condition	$t_{SU}; STO$	4	—	0.6	—	μs
Bus free time between STOP and START condition	t_{BUF}	4.7	—	1.3	—	μs
Pulse width of spikes that must be suppressed by the input filter	t_{SP}	N/A	N/A	0	50	ns

1. The master mode I²C deasserts ACK of an address byte simultaneously with the falling edge of SCL. If no slaves acknowledge this address byte, then a negative hold time can result, depending on the edge rates of the SDA and SCL lines.
2. The maximum $t_{HD}; DAT$ must be met only if the device does not stretch the LOW period (t_{LOW}) of the SCL signal.
3. Input signal Slew = 10 ns and Output Load = 50 pF
4. Set-up time in slave-transmitter mode is 1 IPBus clock period, if the TX FIFO is empty.
5. A Fast mode I²C bus device can be used in a Standard mode I²C bus system, but the requirement $t_{SU}; DAT \geq 250$ ns must then be met. This is automatically the case if the device does not stretch the LOW period of the SCL signal. If such

a device does stretch the LOW period of the SCL signal, then it must output the next data bit to the SDA line $t_{rmax} + t_{SU}$; $t_{HD; DAT} = 1000 + 250 = 1250$ ns (according to the Standard mode I²C bus specification) before the SCL line is released.
 6. C_b = total capacitance of the one bus line in pF.

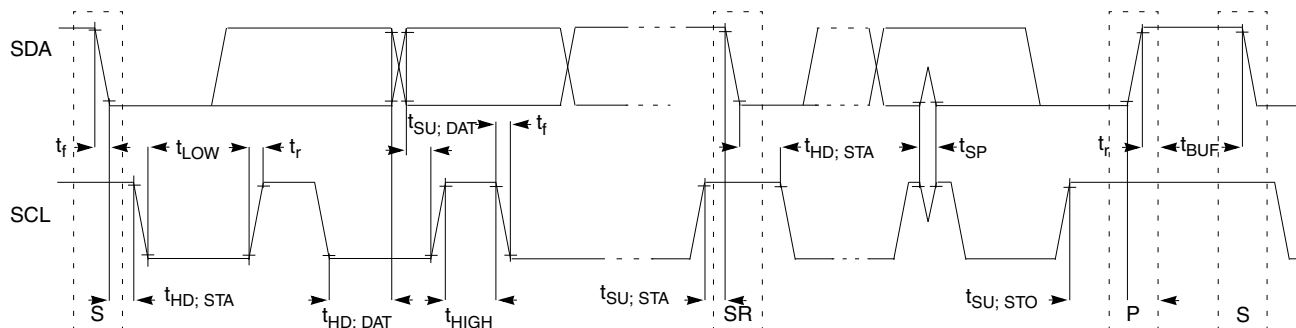

Figure 23. Timing definition for fast and standard mode devices on the I²C bus

3.8.4 UART switching specifications

See [General switching specifications](#).

4 Dimensions

4.1 Obtaining package dimensions

Package dimensions are provided in package drawings.

To find a package drawing, go to freescale.com and perform a keyword search for the drawing's document number:

If you want the drawing for this package	Then use this document number
64-pin LQFP	98ASS23234W
100-pin LQFP	98ASS23308W

5 Pinout

5.1 KV31F Signal Multiplexing and Pin Assignments

The following table shows the signals available on each pin and the locations of these pins on the devices supported by this document. The Port Control Module is responsible for selecting which ALT functionality is available on each pin.

100 LQFP	64 LQFP	Pin Name	Default	ALT0	ALT1	ALT2	ALT3	ALT4	ALT5	ALT6	ALT7	EzPort
1	1	PTE0/ CLKOUT32K	ADC1_SE4a	ADC1_SE4a	PTE0/ CLKOUT32K	SPI1_PCS1	UART1_TX			I2C1_SDA		
2	2	PTE1/ LLWU_P0	ADC1_SE5a	ADC1_SE5a	PTE1/ LLWU_P0	SPI1_SOUT	UART1_RX			I2C1_SCL	SPI1_SIN	
3	—	PTE2/ LLWU_P1	ADC1_SE6a	ADC1_SE6a	PTE2/ LLWU_P1	SPI1_SCK	UART1_ CTS_b					
4	—	PTE3	ADC1_SE7a	ADC1_SE7a	PTE3	SPI1_SIN	UART1_ RTS_b				SPI1_SOUT	
5	—	PTE4/ LLWU_P2	DISABLED		PTE4/ LLWU_P2	SPI1_PCS0	LPUART0_ TX					
6	—	PTE5	DISABLED		PTE5	SPI1_PCS2	LPUART0_ RX					
7	—	PTE6	DISABLED		PTE6	SPI1_PCS3	LPUART0_ CTS_b					
8	3	VDD	VDD	VDD								
9	4	VSS	VSS	VSS								
10	5	PTE16	ADC0_SE4a	ADC0_SE4a	PTE16	SPI0_PCS0	UART2_TX	FTM_CLKIN0		FTM0_FLT3		
11	6	PTE17	ADC0_SE5a	ADC0_SE5a	PTE17	SPI0_SCK	UART2_RX	FTM_CLKIN1		LPTMR0_ ALT3		
12	7	PTE18	ADC0_SE6a	ADC0_SE6a	PTE18	SPI0_SOUT	UART2_ CTS_b	I2C0_SDA				
13	8	PTE19	ADC0_SE7a	ADC0_SE7a	PTE19	SPI0_SIN	UART2_ RTS_b	I2C0_SCL				
14	—	ADC0_DP1	ADC0_DP1	ADC0_DP1								
15	—	ADC0_DM1	ADC0_DM1	ADC0_DM1								
16	—	ADC1_DP1/ ADC0_DP2	ADC1_DP1/ ADC0_DP2	ADC1_DP1/ ADC0_DP2								
17	—	ADC1_DM1/ ADC0_DM2	ADC1_DM1/ ADC0_DM2	ADC1_DM1/ ADC0_DM2								
18	9	ADC0_DP0/ ADC1_DP3	ADC0_DP0/ ADC1_DP3	ADC0_DP0/ ADC1_DP3								
19	10	ADC0_DM0/ ADC1_DM3	ADC0_DM0/ ADC1_DM3	ADC0_DM0/ ADC1_DM3								
20	11	ADC1_DP0/ ADC0_DP3	ADC1_DP0/ ADC0_DP3	ADC1_DP0/ ADC0_DP3								
21	12	ADC1_DM0/ ADC0_DM3	ADC1_DM0/ ADC0_DM3	ADC1_DM0/ ADC0_DM3								
22	13	VDDA	VDDA	VDDA								
23	14	VREFH	VREFH	VREFH								

100 LQFP	64 LQFP	Pin Name	Default	ALT0	ALT1	ALT2	ALT3	ALT4	ALT5	ALT6	ALT7	EzPort
24	15	VREFL	VREFL	VREFL								
25	16	VSSA	VSSA	VSSA								
26	17	VREF_OUT/ CMP1_IN5/ CMP0_IN5/ ADC1_SE18	VREF_OUT/ CMP1_IN5/ CMP0_IN5/ ADC1_SE18	VREF_OUT/ CMP1_IN5/ CMP0_IN5/ ADC1_SE18								
27	18	DAC0_OUT/ CMP1_IN3/ ADC0_SE23	DAC0_OUT/ CMP1_IN3/ ADC0_SE23	DAC0_OUT/ CMP1_IN3/ ADC0_SE23								
28	19	CMP0_IN4/ ADC1_SE23	CMP0_IN4/ ADC1_SE23	CMP0_IN4/ ADC1_SE23								
29	—	VSS	VSS	VSS								
30	—	VDD	VDD	VDD								
31	20	PTE24	ADC0_SE17	ADC0_SE17	PTE24		FTM0_CH0		I2C0_SCL	EWM_OUT_b		
32	21	PTE25	ADC0_SE18	ADC0_SE18	PTE25		FTM0_CH1		I2C0_SDA	EWM_IN		
33	—	PTE26/ CLKOUT32K	DISABLED		PTE26/ CLKOUT32K							
34	22	PTA0	JTAG_TCLK/ SWD_CLK/ EZP_CLK		PTA0	UART0_CTS_b	FTM0_CH5		EWM_IN		JTAG_TCLK/ SWD_CLK	EZP_CLK
35	23	PTA1	JTAG_TDI/ EZP_DI		PTA1	UART0_RX	FTM0_CH6	CMP0_OUT	FTM2_QD_PHA	FTM1_CH1	JTAG_TDI	EZP_DI
36	24	PTA2	JTAG_TDO/ TRACE_SWO/ EZP_DO		PTA2	UART0_TX	FTM0_CH7	CMP1_OUT	FTM2_QD_PHB	FTM1_CH0	JTAG_TDO/ TRACE_SWO	EZP_DO
37	25	PTA3	JTAG_TMS/ SWD_DIO		PTA3	UART0_RTS_b	FTM0_CH0	FTM2_FLT0	EWM_OUT_b		JTAG_TMS/ SWD_DIO	
38	26	PTA4/ LLWU_P3	NMI_b/ EZP_CS_b		PTA4/ LLWU_P3		FTM0_CH1		FTM0_FLT3		NMI_b	EZP_CS_b
39	27	PTA5	DISABLED		PTA5		FTM0_CH2				JTAG_TRST_b	
40	—	VDD	VDD	VDD								
41	—	VSS	VSS	VSS								
42	28	PTA12	DISABLED		PTA12		FTM1_CH0				FTM1_QD_PHA	
43	29	PTA13/ LLWU_P4	DISABLED		PTA13/ LLWU_P4		FTM1_CH1				FTM1_QD_PHB	
44	—	PTA14	DISABLED		PTA14	SPI0_PCS0	UART0_TX					
45	—	PTA15	DISABLED		PTA15	SPI0_SCK	UART0_RX					
46	—	PTA16	DISABLED		PTA16	SPI0_SOUT	UART0_CTS_b					
47	—	PTA17	ADC1_SE17	ADC1_SE17	PTA17	SPI0_SIN	UART0_RTS_b					
48	30	VDD	VDD	VDD								

Pinout

100 LQFP	64 LQFP	Pin Name	Default	ALT0	ALT1	ALT2	ALT3	ALT4	ALT5	ALT6	ALT7	EzPort
49	31	VSS	VSS	VSS								
50	32	PTA18	EXTAL0	EXTAL0	PTA18		FTM0_FLT2	FTM_CLKIN0				
51	33	PTA19	XTAL0	XTAL0	PTA19	FTM0_FLT0	FTM1_FLT0	FTM_CLKIN1		LPTMR0_ALT1		
52	34	RESET_b	RESET_b	RESET_b								
53	35	PTB0/LLWU_P5	ADC0_SE8/ADC1_SE8	ADC0_SE8/ADC1_SE8	PTB0/LLWU_P5	I2C0_SCL	FTM1_CH0			FTM1_QD_PHA	UART0_RX	
54	36	PTB1	ADC0_SE9/ADC1_SE9	ADC0_SE9/ADC1_SE9	PTB1	I2C0_SDA	FTM1_CH1	FTM0_FLT2	EWM_IN	FTM1_QD_PHB	UART0_TX	
55	37	PTB2	ADC0_SE12	ADC0_SE12	PTB2	I2C0_SCL	UART0_RTS_b	FTM0_FLT1		FTM0_FLT3		
56	38	PTB3	ADC0_SE13	ADC0_SE13	PTB3	I2C0_SDA	UART0_CTS_b			FTM0_FLT0		
57	—	PTB9	DISABLED		PTB9	SPI1_PCS1	LPUART0_CTS_b					
58	—	PTB10	ADC1_SE14	ADC1_SE14	PTB10	SPI1_PCS0	LPUART0_RX			FTM0_FLT1		
59	—	PTB11	ADC1_SE15	ADC1_SE15	PTB11	SPI1_SCK	LPUART0_TX			FTM0_FLT2		
60	—	VSS	VSS	VSS								
61	—	VDD	VDD	VDD								
62	39	PTB16	DISABLED		PTB16	SPI1_SOUT	UART0_RX	FTM_CLKIN0		EWM_IN		
63	40	PTB17	DISABLED		PTB17	SPI1_SIN	UART0_TX	FTM_CLKIN1		EWM_OUT_b		
64	41	PTB18	DISABLED		PTB18		FTM2_CH0			FTM2_QD_PHA		
65	42	PTB19	DISABLED		PTB19		FTM2_CH1			FTM2_QD_PHB		
66	—	PTB20	DISABLED		PTB20					CMP0_OUT		
67	—	PTB21	DISABLED		PTB21					CMP1_OUT		
68	—	PTB22	DISABLED		PTB22							
69	—	PTB23	DISABLED		PTB23		SPI0_PCS5					
70	43	PTC0	ADC0_SE14	ADC0_SE14	PTC0	SPI0_PCS4	PDB0_EXTRG			FTM0_FLT1	SPI0_PCS0	
71	44	PTC1/LLWU_P6	ADC0_SE15	ADC0_SE15	PTC1/LLWU_P6	SPI0_PCS3	UART1_RTS_b	FTM0_CH0			LPUART0_RTS_b	
72	45	PTC2	ADC0_SE4b/CMP1_IN0	ADC0_SE4b/CMP1_IN0	PTC2	SPI0_PCS2	UART1_CTS_b	FTM0_CH1			LPUART0_CTS_b	
73	46	PTC3/LLWU_P7	CMP1_IN1	CMP1_IN1	PTC3/LLWU_P7	SPI0_PCS1	UART1_RX	FTM0_CH2	CLKOUT		LPUART0_RX	
74	47	VSS	VSS	VSS								
75	48	VDD	VDD	VDD								
76	49	PTC4/LLWU_P8	DISABLED		PTC4/LLWU_P8	SPI0_PCS0	UART1_TX	FTM0_CH3		CMP1_OUT	LPUART0_TX	

100 LQFP	64 LQFP	Pin Name	Default	ALT0	ALT1	ALT2	ALT3	ALT4	ALT5	ALT6	ALT7	EzPort
77	50	PTC5/ LLWU_P9	DISABLED		PTC5/ LLWU_P9	SPI0_SCK	LPTMR0_ ALT2			CMP0_OUT	FTM0_CH2	
78	51	PTC6/ LLWU_P10	CMP0_IN0	CMP0_IN0	PTC6/ LLWU_P10	SPI0_SOUT	PDB0_ EXTRG				I2C0_SCL	
79	52	PTC7	CMP0_IN1	CMP0_IN1	PTC7	SPI0_SIN					I2C0_SDA	
80	53	PTC8	ADC1_SE4b/ CMP0_IN2	ADC1_SE4b/ CMP0_IN2	PTC8							
81	54	PTC9	ADC1_SE5b/ CMP0_IN3	ADC1_SE5b/ CMP0_IN3	PTC9					FTM2_FLT0		
82	55	PTC10	ADC1_SE6b	ADC1_SE6b	PTC10	I2C1_SCL						
83	56	PTC11/ LLWU_P11	ADC1_SE7b	ADC1_SE7b	PTC11/ LLWU_P11	I2C1_SDA						
84	—	PTC12	DISABLED		PTC12							
85	—	PTC13	DISABLED		PTC13							
86	—	PTC14	DISABLED		PTC14							
87	—	PTC15	DISABLED		PTC15							
88	—	VSS	VSS	VSS								
89	—	VDD	VDD	VDD								
90	—	PTC16	DISABLED		PTC16		LPUART0_ RX					
91	—	PTC17	DISABLED		PTC17		LPUART0_ TX					
92	—	PTC18	DISABLED		PTC18		LPUART0_ RTS_b					
93	57	PTD0/ LLWU_P12	DISABLED		PTD0/ LLWU_P12	SPI0_PCS0	UART2_ RTS_b	FTM0_CH0		LPUART0_ RTS_b		
94	58	PTD1	ADC0_SE5b	ADC0_SE5b	PTD1	SPI0_SCK	UART2_ CTS_b	FTM0_CH1		LPUART0_ CTS_b		
95	59	PTD2/ LLWU_P13	DISABLED		PTD2/ LLWU_P13	SPI0_SOUT	UART2_RX	FTM0_CH2		LPUART0_ RX	I2C0_SCL	
96	60	PTD3	DISABLED		PTD3	SPI0_SIN	UART2_TX	FTM0_CH3		LPUART0_ TX	I2C0_SDA	
97	61	PTD4/ LLWU_P14	DISABLED		PTD4/ LLWU_P14	SPI0_PCS1	UART0_ RTS_b	FTM0_CH4		EWM_IN	SPI1_PCS0	
98	62	PTD5	ADC0_SE6b	ADC0_SE6b	PTD5	SPI0_PCS2	UART0_ CTS_b	FTM0_CH5		EWM_OUT_ b	SPI1_SCK	
99	63	PTD6/ LLWU_P15	ADC0_SE7b	ADC0_SE7b	PTD6/ LLWU_P15	SPI0_PCS3	UART0_RX	FTM0_CH6		FTM0_FLT0	SPI1_SOUT	
100	64	PTD7	DISABLED		PTD7		UART0_TX	FTM0_CH7		FTM0_FLT1	SPI1_SIN	

5.2 KV31F Pinouts

The following figure shows the pinout diagram for the devices supported by this document. Many signals may be multiplexed onto a single pin. To determine what signals can be used on which pin, see the previous section.

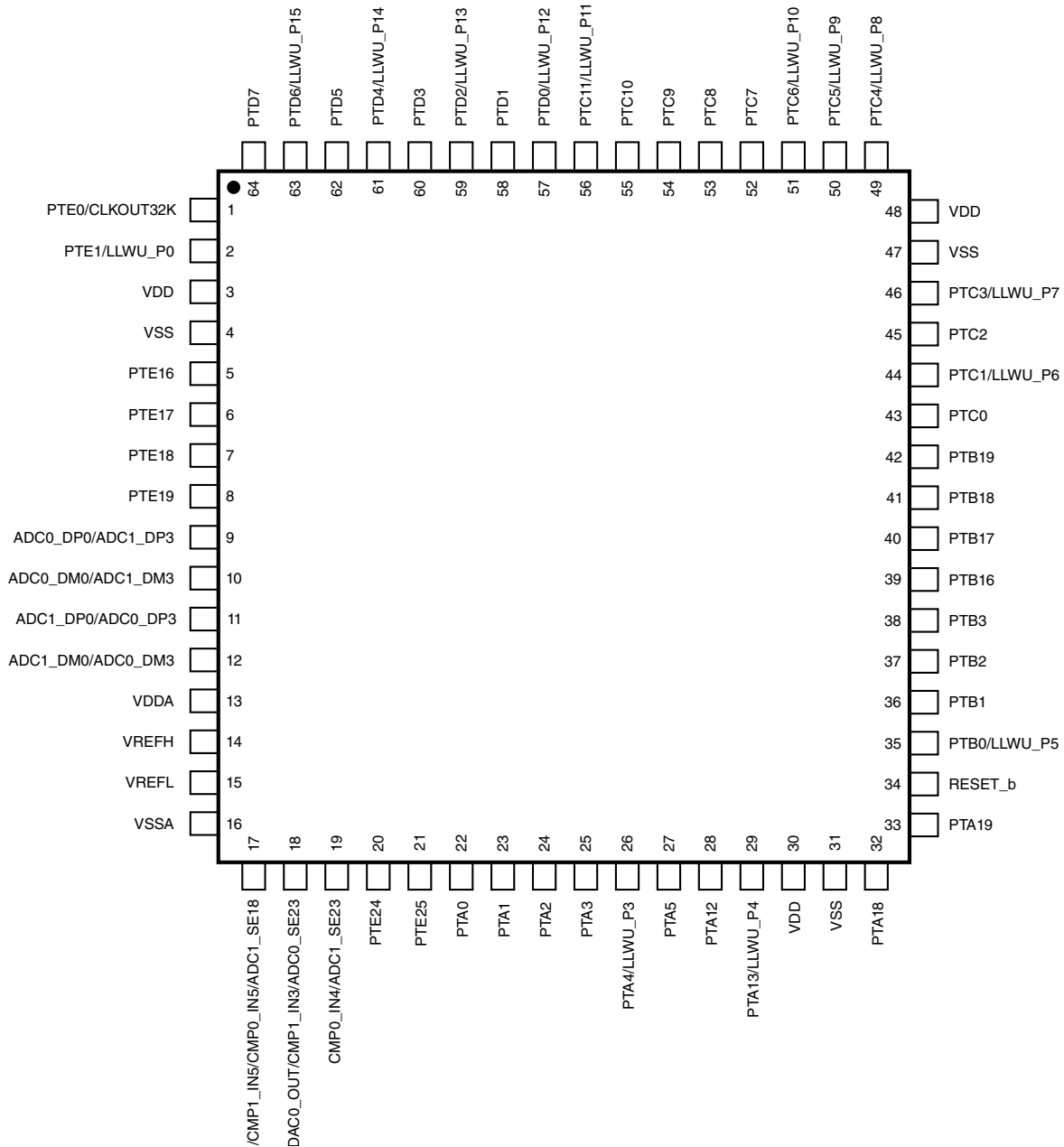

Figure 24. KV31F 64 LQFP Pinout Diagram

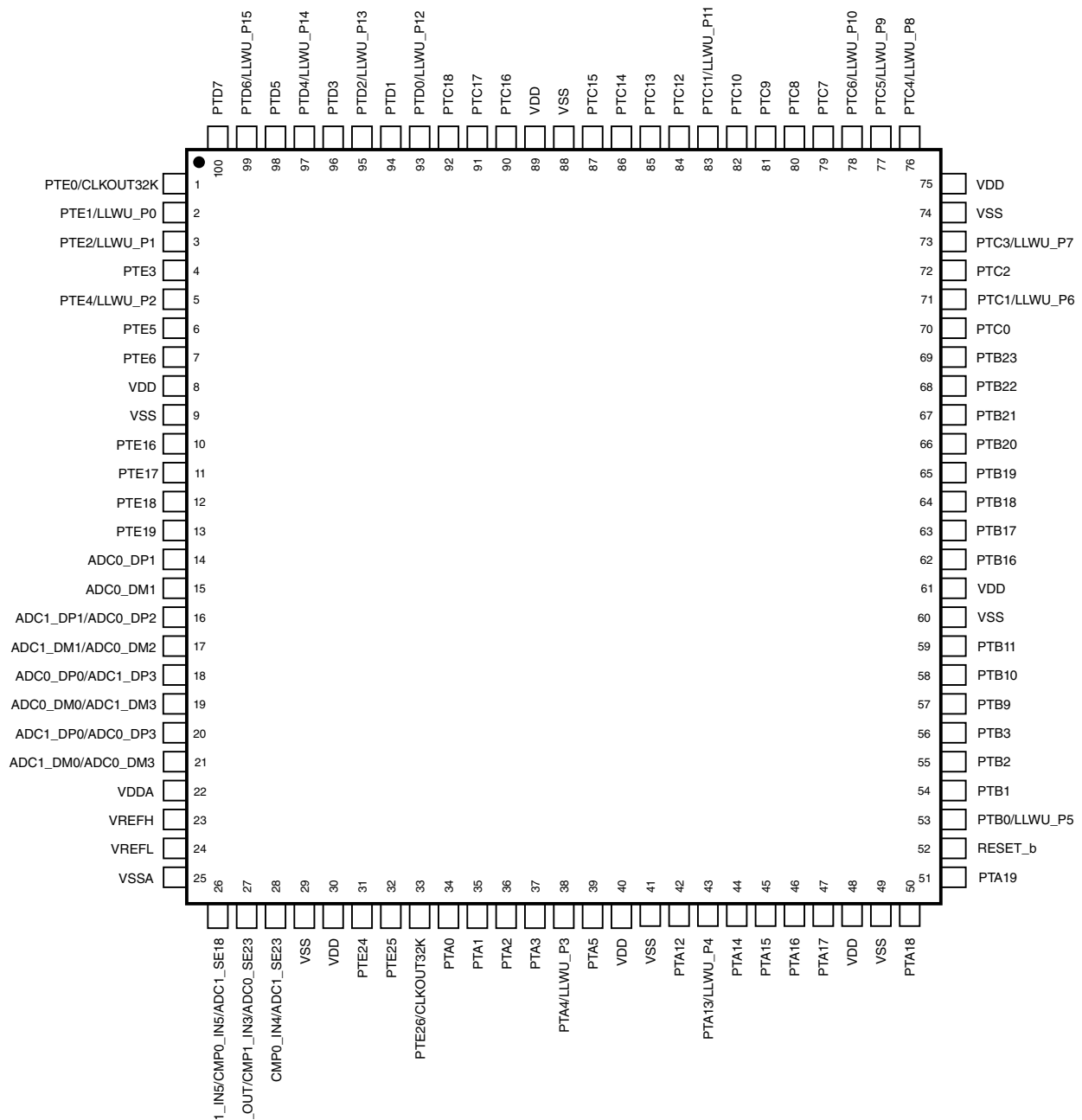

Figure 25. KV31F 100 LQFP Pinout Diagram

6 Ordering parts

6.1 Determining valid orderable parts

Valid orderable part numbers are provided on the web. To determine the orderable part numbers for this device, go to freescale.com and perform a part number search for the following device numbers: PKV31 and MKV31.

7 Part identification

7.1 Description

Part numbers for the chip have fields that identify the specific part. You can use the values of these fields to determine the specific part you have received.

7.2 Format

Part numbers for this device have the following format:

Q KV## A FFF R T PP CC N

7.3 Fields

This table lists the possible values for each field in the part number (not all combinations are valid):

Field	Description	Values
Q	Qualification status	<ul style="list-style-type: none"> M = Fully qualified, general market flow P = Prequalification
KV##	Kinetis V Series	<ul style="list-style-type: none"> KV3x: Cortex-M4 based MCU
A	Key attribute	<ul style="list-style-type: none"> D = Cortex-M4 w/ DSP F = Cortex-M4 w/ DSP and FPU
FFF	Program flash memory size	<ul style="list-style-type: none"> 64 = 64 KB 128 = 128 KB 256 = 256 KB 512 = 512 KB
R	Silicon revision	<ul style="list-style-type: none"> (Blank) = Main A = Revision after main
T	Temperature range (°C)	<ul style="list-style-type: none"> V = -40 to 105 C = -40 to 85
PP	Package identifier	<ul style="list-style-type: none"> FM = 32 QFN (5 mm x 5 mm)

Table continues on the next page...

Field	Description	Values
		<ul style="list-style-type: none"> LF = 48 LQFP¹ (7 mm x 7 mm) LH = 64 LQFP (10 mm x 10 mm) LL = 100 LQFP (14 mm x 14 mm) MC = 121 XFBGA (8 mm x 8 mm) DC = 121 XFBGA (8 mm x 8 mm x 0.5 mm)
CC	Maximum CPU frequency (MHz)	<ul style="list-style-type: none"> 10 = 100 MHz 12 = 120 MHz
N	Packaging type	<ul style="list-style-type: none"> R = Tape and reel (Blank) = Trays

1. This package offering is subject to removal.

7.4 Example

This is an example part number:

MKV31F256VLL12

8 Revision History

The following table provides a revision history for this document.

Table 36. Revision History

Rev. No.	Date	Substantial Changes
4	7/2014	<p>In "Power consumption operating behaviors table":</p> <ul style="list-style-type: none"> Updated existing typical power measurements Added new typical power measurements for the following: <ul style="list-style-type: none"> IDD_HSRUN (High Speed Run mode current executing CoreMark code) IDD_RUNCO (Run mode current in Compute operation, executing CoreMark code) IDD_RUN (Run mode current in Compute operation, executing while(1) loop) IDD_VLPR (Very Low Power mode current executing CoreMark code) IDD_VLPR (Very Low Power Run mode current in Compute operation, executing while(1) loop)
3	7/2014	<ul style="list-style-type: none"> On p. 1: <ul style="list-style-type: none"> Updated introduction Under "Memories and memory interfaces," added bullet, "Pre-programmed Kinetis flashloader for one-time, in-system factory programming" Under "Security and integrity modules," added bullet, "Hardware random-number generator" In "Voltage and current operating ratings" table, updated maximum digital supply current Updated "Voltage and current operating behaviors" table Updated "Power mode transition operating behaviors" table Updated "Power consumption operating behaviors" table

Table continues on the next page...

Revision History

Table 36. Revision History (continued)

Rev. No.	Date	Substantial Changes
		<ul style="list-style-type: none">• Updated figure, "Run Mode Current vs Core Frequency"• Updated figure, "Very Low Power Run (VLPR) Current vs Core Frequency"• Updated "EMC radiated emissions operating behaviors for 64 LQFP package" table• Updated "Thermal attributes" table• Updated "MCG specifications" table• Updated "IRC48M specifications" table• Updated "16-bit ADC operating conditions" table• Updated "Voltage reference electrical specifications" section
2	3/2014	Initial public release

How to Reach Us:

Home Page:

freescale.com

Web Support:

freescale.com/support

Information in this document is provided solely to enable system and software implementers to use Freescale products. There are no express or implied copyright licenses granted hereunder to design or fabricate any integrated circuits based on the information in this document. Freescale reserves the right to make changes without further notice to any products herein.

Freescale makes no warranty, representation, or guarantee regarding the suitability of its products for any particular purpose, nor does Freescale assume any liability arising out of the application or use of any product or circuit, and specifically disclaims any and all liability, including without limitation consequential or incidental damages. "Typical" parameters that may be provided in Freescale data sheets and/or specifications can and do vary in different applications, and actual performance may vary over time. All operating parameters, including "typicals," must be validated for each customer application by customer's technical experts. Freescale does not convey any license under its patent rights nor the rights of others. Freescale sells products pursuant to standard terms and conditions of sale, which can be found at the following address: freescale.com/SalesTermsandConditions.

Freescale, the Freescale logo, and Kinetis are trademarks of Freescale Semiconductor, Inc., Reg. U.S. Pat. & Tm. Off. All other product or service names are the property of their respective owners. ARM and Cortex are registered trademarks of ARM Limited (or its subsidiaries) in the EU and/or elsewhere. All rights reserved.

© 2014 Freescale Semiconductor, Inc.

Document Number KV31P100M120SF8
Revision 4, 07/2014

