



Single-Axis SPI Inertial Sensor

MMA655x, a SafeAssure solution, is a SPI-based, single-axis, medium-g, over-damped lateral accelerometer designed for use in Automotive Airbag systems.

Features

- $\pm 105g$ or $\pm 120g$ full-scale range
- 3.3V or 5V single supply operation
- SPI-compatible serial interface
- 12-bit digital signed or unsigned SPI data output
- Programmable arming function
- Twelve low-pass filter options, ranging from 50 Hz to 1000 Hz
- Optional offset cancellation with $> 6s$ averaging period and < 0.25 LSB/s slew rate
- Pb-Free 16-Pin QFN, 6 by 6 Package

Referenced Documents

- AECQ100, Revision G, dated May 14, 2007 (<http://www.aecouncil.com/>)

MMA655x

Bottom View



**16 LEAD QFN
6 mm by 6 mm
CASE 2086-01**

ORDERING INFORMATION

Device	Axis	Range	Shipping
MMA6555KW	X	105g	Tubes
MMA6556KW	X	120g	Tubes
MMA6555KWR2	X	105g	Tape & Reel
MMA6556KWR2	X	120g	Tape & Reel

For user register array programming, please consult your Freescale representative.

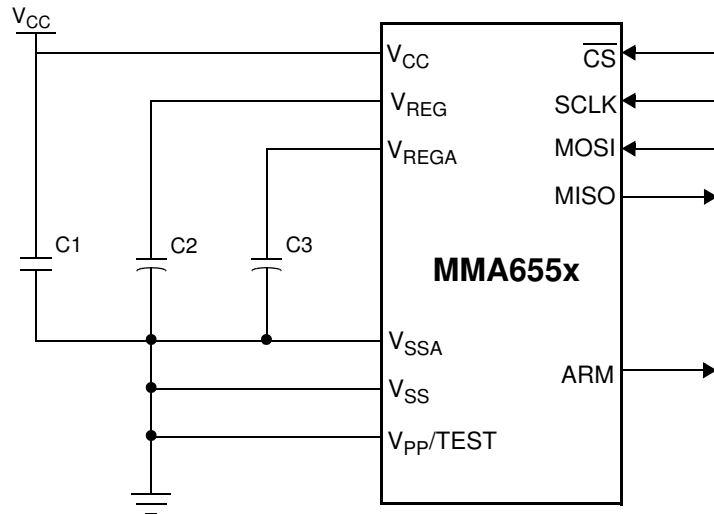

Figure 1. Application Diagram

Table 1. External Component Recommendations

Ref Des	Type	Description	Purpose
C1	Ceramic	0.1 μ F, 10%, 10V Minimum, X7R	V _{CC} Power Supply Decoupling
C2	Ceramic	1 μ F, 10%, 10V Minimum, X7R	Voltage Regulator Output Capacitor (C _{VREG})
C3	Ceramic	1 μ F, 10%, 10V Minimum, X7R	Voltage Regulator Output Capacitor (C _{VREGA})

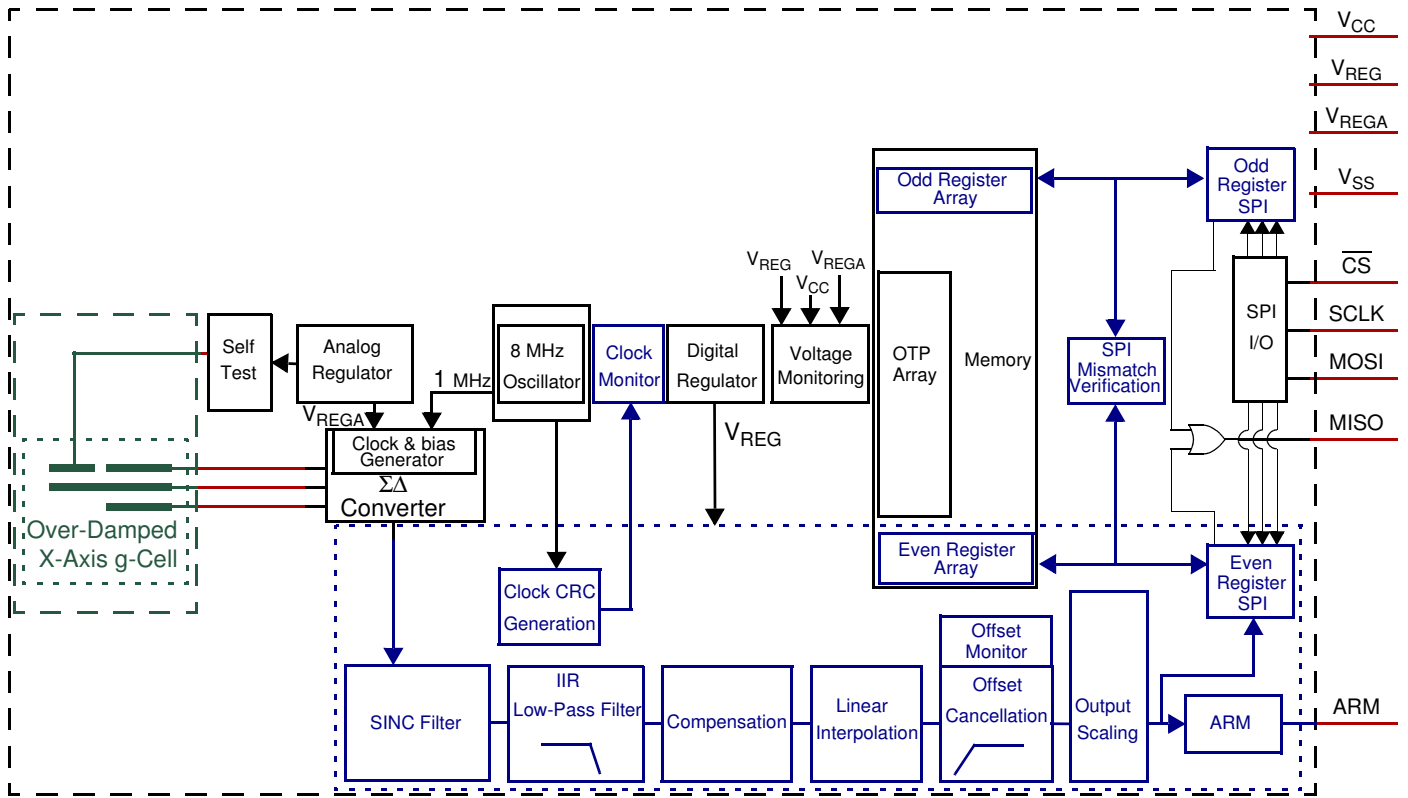

Figure 2. Internal Block Diagram

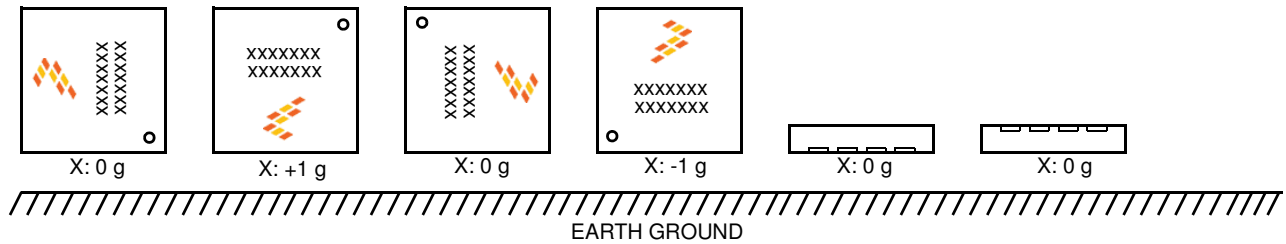

Figure 3. Device Orientation Diagram

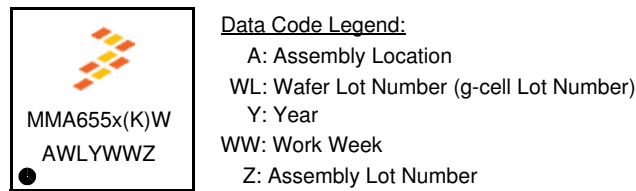

Figure 4. Part Marking

1 Pin Connections

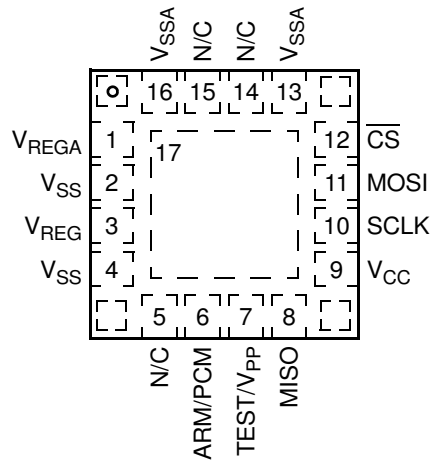

Figure 5. Top View, 16 Pin QFN Package

Table 2. Pin Descriptions

Pin	Pin Name	Formal Name	Definition
1	V _{REGA}	Analog Supply	This pin is connected to the power supply for the internal analog circuitry. An external capacitor must be connected between this pin and V _{SSA} . Reference Figure 1 .
2	V _{SS}	Digital GND	This pin is the power supply return node for the digital circuitry.
3	V _{REG}	Digital Supply	This pin is connected to the power supply for the internal digital circuitry. An external capacitor must be connected between this pin and V _{SS} . Reference Figure 1 .
4	V _{SS}	Digital GND	This pin is the power supply return node for the digital circuitry.
5	N/C	No Connect	No Connection
6	ARM/PCM	Arm Output / PCM Output	The function of this pin is configurable via the DEVCFG register as described in Section 3.1.6.6 . When the arming output is selected, ARM can be configured as an open drain, active low output with a pullup current; or an open drain, active high output with a pulldown current. Alternatively, this pin can be configured as a digital output with a PCM signal proportional to the acceleration data. Reference Section 3.1.10 and Section 3.1.11 . If unused, this pin must be left unconnected.
7	TEST / V _{PP}	Programming Voltage	This pin provides the power for factory programming of the OTP registers. This pin must be connected to V _{SS} in the application.
8	MISO	SPI Data Out	This pin functions as the serial data output for the SPI port.
9	V _{CC}	Supply	This pin supplies power to the device. An external capacitor must be connected between this pin and V _{SS} . Reference Figure 1 .
10	SCLK	SPI Clock	This input pin provides the serial clock to the SPI port. An internal pulldown device is connected to this pin.
11	MOSI	SPI Data In	This pin functions as the serial data input to the SPI port. An internal pulldown device is connected to this pin.
12	CS	Chip Select	This input pin provides the chip select for the SPI port. An internal pullup device is connected to this pin.
13	V _{SSA}	Analog GND	This pin is the power supply return node for analog circuitry.
14	NC	No Connect	Not internally connected. This pin can be unconnected or connected to V _{SS} in the application.
15	NC	No Connect	Not internally connected. This pin can be unconnected or connected to V _{SS} in the application.
16	V _{SSA}	Analog GND	This pin is the power supply return node for analog circuitry
17	PAD	Die Attach Pad	This pin is the die attach flag, and is internally connected to V _{SS} . Reference Section 5 for die attach pad connection details.
Corner Pads			The corner pads are internally connected to V _{SS} .

2 Electrical Characteristics

2.1 Maximum Ratings

Maximum ratings are the extreme limits to which the device can be exposed without permanently damaging it.

#	Rating	Symbol	Value	Unit	
1	Supply Voltage	V_{CC}	-0.3 to +7.0	V	(3)
2	V_{REG}, V_{REGA}	V_{REG}	-0.3 to +3.0	V	(3)
3	SCLK, \overline{CS} , MOSI, $V_{PP}/TEST$	V_{IN}	-0.3 to $V_{CC} + 0.3$	V	(3)
4	ARM	V_{IN}	-0.3 to $V_{CC} + 0.3$	V	(3)
5	MISO (high impedance state)	V_{IN}	-0.3 to $V_{CC} + 0.3$	V	(3)
6	Powered Shock (six sides, 0.5 ms duration)	g_{pms}	± 1500	g	(5,18)
7	Unpowered Shock (six sides, 0.5 ms duration)	g_{shock}	± 2000	g	(5,18)
8	Drop Shock (to concrete surface)	h_{DROP}	1.2	m	(5)
9	Electrostatic Discharge Human Body Model (HBM)	V_{ESD}	± 2000	V	(5)
10	Charge Device Model (CDM)	V_{ESD}	± 750	V	(5)
11	Machine Model (MM)	V_{ESD}	± 200	V	(5)
12	Storage Temperature Range	T_{stg}	-40 to +125	$^{\circ}C$	(5)
13	Thermal Resistance - Junction to Case	θ_{JC}	2.5	$^{\circ}C/W$	(14)

2.2 Operating Range

The operating ratings are the limits normally expected in the application and define the range of operation.

#	Characteristic	Symbol	Min	Typ	Max	Units	
14	Supply Voltage	V_{CC}	V_L +3.135	V_{TYP} +3.3	V_H +5.25	V	(15)
15	Standard Operating Voltage, 5.0V						+5.0
16	Operating Ambient Temperature Range Verified by 100% Final Test	T_A	T_L -40	—	T_H +105	C	(1)
17	Power-on Ramp Rate (V_{CC})	V_{CC_r}	0.000033	—	3300	V/ μs	(19)

2.3 Electrical Characteristics - Power Supply and I/O

$V_L \leq (V_{CC} - V_{SS}) \leq V_H$, $T_L \leq T_A \leq T_H$, $|\Delta T_A| < 25$ K/min unless otherwise specified

#	Characteristic	Symbol	Min	Typ	Max	Units	
18	Supply Current	I_{DD}	3.0	—	7.0	mA	(1)
Power Supply Monitor Thresholds (See Figure 9)							
19	V_{CC} Undervoltage (Falling)	$V_{CC_UV_f}$	2.74	—	3.02	V	(3,6)
20	V_{REG} Undervoltage (Falling)	$V_{REG_UV_f}$	2.10	—	2.25	V	(3,6)
21	V_{REG} Overvoltage (Rising)	$V_{REG_OV_r}$	2.65	—	2.85	V	(3,6)
22	V_{REGA} Undervoltage (Falling)	$V_{REGA_UV_f}$	2.20	—	2.35	V	(3,6)
23	V_{REGA} Overvoltage (Rising)	$V_{REGA_OV_r}$	2.65	—	2.85	V	(3,6)
Power Supply Monitor Hysteresis							
24	V_{CC} Undervoltage	V_{HYST}	65	100	110	mV	(3)
25	V_{REG} Undervoltage, V_{REG} Overvoltage	V_{HYST}	20	100	210	mV	(3)
26	V_{REGA} Undervoltage, V_{REGA} Overvoltage	V_{HYST}	20	100	150	mV	(3)
Power Supply RESET Thresholds (See Figure 6, and Figure 9)							
27	V_{REG} Undervoltage RESET (Falling)	$V_{REG_UVR_f}$	1.764	—	2.024	V	(3,6)
28	V_{REG} Undervoltage RESET (Rising)	$V_{REG_UVR_r}$	1.876	—	2.152	V	(3,6)
29	V_{REG} RESET Hysteresis	V_{HYST}	80	—	140	mV	(3)
Internally Regulated Voltages							
30	V_{REG}	V_{REG}	2.42	2.50	2.58	V	(1,3)
31	V_{REGA}	V_{REGA}	2.42	2.50	2.58	V	(1,3)
External Filter Capacitor (C_{VREG} , C_{VREGA})							
32	Value	C_{VREG} , C_{VREGA}	700	1000	1500	nF	(19)
33	ESR (including interconnect resistance)	ESR	—	—	400	m Ω	(19)
Power Supply Coupling							
34	$50 \text{ kHz} \leq f_n \leq 300 \text{ kHz}$		—	—	0.004	LSB/mv	(19)
35	$4 \text{ MHz} \leq f_n \leq 100 \text{ MHz}$		—	—	0.004	LSB/mv	(19)
Output High Voltage (MISO, PCM)							
36	$3.15 \text{ V} \leq (V_{CC} - V_{SS}) \leq 3.45 \text{ V}$ ($I_{Load} = -1 \text{ mA}$)	V_{OH_3}	$V_{CC} - 0.2$	—	—	V	(2,3)
37	$4.75 \text{ V} \leq (V_{CC} - V_{SS}) \leq 5.25 \text{ V}$ ($I_{Load} = -1 \text{ mA}$)	V_{OH_5}	$V_{CC} - 0.4$	—	—	V	(2,3)
Output Low Voltage (MISO, PCM)							
38	$3.15 \text{ V} \leq (V_{CC} - V_{SS}) \leq 3.45 \text{ V}$ ($I_{Load} = 1 \text{ mA}$)	V_{OL_3}	—	—	0.2	V	(2,3)
39	$4.75 \text{ V} \leq (V_{CC} - V_{SS}) \leq 5.25 \text{ V}$ ($I_{Load} = 1 \text{ mA}$)	V_{OL_5}	—	—	0.4	V	(2,3)
Open Drain Output High Voltage (ARM)							
40	$3.15 \text{ V} \leq (V_{CC} - V_{SS}) \leq 3.45 \text{ V}$ ($I_{ARM} = -1 \text{ mA}$)	V_{ODH_3}	$V_{CC} - 0.2$	—	—	V	(2,3)
41	$4.75 \text{ V} \leq (V_{CC} - V_{SS}) \leq 5.25 \text{ V}$ ($I_{ARM} = -1 \text{ mA}$)	V_{ODH_5}	$V_{CC} - 0.4$	—	—	V	(2,3)
Open Drain Output Pulldown Current (ARM)							
42	$3.15 \text{ V} \leq (V_{CC} - V_{SS}) \leq 3.45 \text{ V}$ ($V_{ARM} = 1.5\text{V}$)	I_{ODPD_3}	50	—	100	μA	(2,3)
43	$4.75 \text{ V} \leq (V_{CC} - V_{SS}) \leq 5.25 \text{ V}$ ($V_{ARM} = 1.5\text{V}$)	I_{ODPD_5}	50	—	100	μA	(2,3)
Open Drain Output Low Voltage (ARM)							
44	$3.15 \text{ V} \leq (V_{CC} - V_{SS}) \leq 3.45 \text{ V}$ ($I_{ARM} = 1 \text{ mA}$)	V_{ODH_3}	—	—	0.2	V	(2,3)
45	$4.75 \text{ V} \leq (V_{CC} - V_{SS}) \leq 5.25 \text{ V}$ ($I_{ARM} = 1 \text{ mA}$)	V_{ODH_5}	—	—	0.4	V	(2,3)
Open Drain Output Pullup Current (ARM)							
46	$3.15 \text{ V} \leq (V_{CC} - V_{SS}) \leq 3.45 \text{ V}$ ($V_{ARM} = 1.5\text{V}$)	I_{ODPU_3}	-100	—	-50	μA	(2,3)
47	$4.75 \text{ V} \leq (V_{CC} - V_{SS}) \leq 5.25 \text{ V}$ ($V_{ARM} = 1.5\text{V}$)	I_{ODPU_5}	-100	—	-50	μA	(2,3)
48	Input High Voltage \overline{CS} , SCLK, MOSI	V_{IH}	2.0	—	—	V	(3,6)
49	Input Low Voltage \overline{CS} , SCLK, MOSI	V_{IL}	—	—	1.0	V	(3,6)
50	Input Voltage Hysteresis \overline{CS} , SCLK, MOSI	V_{L_HYST}	0.125	—	0.500	V	(19)
Input Current							
51	High (at V_{IH})(SCLK, MOSI)	I_{IH}	-70	-50	-30	μA	(2,3)
52	Low (at V_{IL})(\overline{CS})	I_{IL}	30	50	70	μA	(2,3)

2.4 Electrical Characteristics - Sensor and Signal Chain

$V_L \leq (V_{CC} - V_{SS}) \leq V_H$, $T_L \leq T_A \leq T_H$, $|\Delta T_A| < 25$ K/min unless otherwise specified.

#	Characteristic	Symbol	Min	Typ	Max	Units	
53	Digital Sensitivity (SPI) 105.5g (12-Bit Output)	* SENS	—	18.2	—	LSB/g	(1,9)
54	120 g (12-Bit Output)	* SENS	—	16.0	—	LSB/g	(1,9)
55	Sensitivity Error $T_A = 25$ C	* Δ SENS	-4	—	+4	%	(1)
56	-40 C $\leq T_A \leq 105$ C	* Δ SENS	-5	—	+5	%	(1)
57	-40 C $\leq T_A \leq 105$ C, $V_{CC_UV_f} \leq V_{CC} - V_{SS} \leq V_L$	* Δ SENS	-5	—	+5	%	(3)
58a	Offset at 0 g (No Offset Cancellation) 12 bits, unsigned	* OFFSET	1988	2048	2108	LSB	(1)
59a	12 bits, signed	* OFFSET	-60	0	+60	LSB	(1)
60a	12 bits, unsigned, $V_{CC_UV_f} \leq V_{CC} - V_{SS} \leq V_L$	* OFFSET	1988	—	1988	LSB	(3)
61a	12 bits, signed, $V_{CC_UV_f} \leq V_{CC} - V_{SS} \leq V_L$	* OFFSET	-60	—	-60	LSB	(3)
62b	Offset at 0g (With Offset Cancellation) 12 bits, unsigned	* OFFSET	2047.75	2048	2048.25	LSB	(9,7)
63b	12 bits, signed	* OFFSET	-0.25	0	+0.25	LSB	(9,7)
64b	12 bits, unsigned, $V_{CC_UV_f} \leq V_{CC} - V_{SS} \leq V_L$	* OFFSET	2047.75	—	2048.25	LSB	(9)
65b	12 bits, signed, $V_{CC_UV_f} \leq V_{CC} - V_{SS} \leq V_L$	* OFFSET	-0.25	—	+0.25	LSB	(9)
66	Offset Monitor Thresholds Positive Threshold (12 bits signed)	OFFTHR _{POS}	—	100	—	LSB	(7)
67	Negative Threshold (12 bits signed)	OFFTHR _{NEG}	—	-100	—	LSB	(7)
68	Range of Output (SPI, 12 bits, unsigned) Normal	RANGE	128	—	3968	LSB	(7)
69	Fault Response Code	FAULT	—	0	—	LSB	(7)
70	Unused Codes	UNUSED	1	—	127	LSB	(7)
71	Unused Codes	UNUSED	3969	—	4095	LSB	(7)
72	Range of Output (SPI, 12 bits, signed) Normal	RANGE	-1920	—	1920	LSB	(7)
73	Unused Codes	UNUSED	-2047	—	-1921	LSB	(7)
74	Unused Codes	UNUSED	1921	—	2047	LSB	(7)
75	Nonlinearity	* NL _{OUT}	-1	—	1	% FSR	(3)
76	System Output Noise RMS (12 bits, All Ranges, 400 Hz, 3-pole LPF)	η_{RMS}	—	—	1	LSB	(3)
77	Peak to Peak (12 bits, All Ranges, 400 Hz, 3-pole LPF)	η_{P-P}	—	—	3	LSB	(3)
78	Cross-Axis Sensitivity V_{ZX}	* V_{ZX}	-4	—	+4	%	(3)
79	V_{YX}	* V_{YX}	-4	—	+4	%	(3)
80	Self Test Output Change (Ref Section 3.6) 105.5g, $T_A = 25$ C	* ΔST_{105_25}	ΔST_{MIN} 442	ΔST_{NOM} 553	ΔST_{MAX} 663	LSB	(1)
81	105.5g, -40 C $\leq T_A \leq 105$ C	* ΔST_{105_AT}	414	553	690	LSB	(1)
82	105.5g, -40 C $\leq T_A \leq 105$ C, $V_{CC_UV_f} \leq V_{CC} - V_{SS} \leq V_L$	* $\Delta ST_{105_AT\Delta V}$	414	553	690	LSB	(3)
83	120g, $T_A = 25$ C	* ΔST_{120_25}	387	484	581	LSB	(1)
84	120g, -40 C $\leq T_A \leq 105$ C	* ΔST_{120_AT}	363	484	605	LSB	(1)
85	120g, -40 C $\leq T_A \leq 105$ C, $V_{CC_UV_f} \leq V_{CC} - V_{SS} \leq V_L$	* $\Delta ST_{120_AT\Delta V}$	363	484	605	LSB	(3)
86	Self Test Output Accuracy Δ from Stored Value, including Sensitivity Error -40 C $\leq T_A \leq 105$ C (Ref Section 3.6)	* ΔST_{ACC}	-10	—	+10	%	(3)
87	Sigma Delta Modulator Range	g_{ADCL_Clip}	375	400	450	g	(19)
88	Acceleration (without hitting internal g-cell stops)	g_{g-cell_Clip}	500	560	600	g	(19)

2.5 Dynamic Electrical Characteristics - Signal Chain

$V_L \leq (V_{CC} - V_{SS}) \leq V_H$, $T_L \leq T_A \leq T_H$, $|\Delta T_A| < 25$ K/min unless otherwise specified.

#	Characteristic	Symbol	Min	Typ	Max	Units	
89	DSP Sample Rate (LPF 0,1,2,3,4,5)	t_S	—	$64/f_{OSC}$	—	s	(7)
90	DSP Sample Rate (LPF 8,9,10,11,12,13)	t_S	—	$128/f_{OSC}$	—	s	(7)
91	Interpolation Sample Rate	t_{INTERP}	—	$t_S/2$	—	s	(7)
92	Data Path Latency (excluding g-cell and Low Pass Filter) $T_S = 64/f_{OSC}$ *	$t_{DataPath_8}$	33.0	34.8	36.5	μs	(7,16)
93	$T_S = 128/f_{OSC}$ *	$t_{DataPath_16}$	51.9	54.6	57.4	μs	(7,16)
94	Low-Pass Filter ($t_S = 8\mu s$) Cutoff frequency 0: 100 Hz, 4-pole *	$f_{C0(LPF)}$	95	100	105	Hz	(3,7,17)
95	Cutoff frequency 1: 300 Hz, 4-pole *	$f_{C1(LPF)}$	285	300	315	Hz	(3,7,17)
96	Cutoff frequency 2: 400 Hz, 4-pole *	$f_{C2(LPF)}$	380	400	420	Hz	(3,7,17)
97	Cutoff frequency 3: 800 Hz, 4-pole *	$f_{C3(LPF)}$	760	800	840	Hz	(3,7,17)
98	Cutoff frequency 4: 1000 Hz, 4-pole *	$f_{C4(LPF)}$	950	1000	1050	Hz	(3,7,17)
99	Cutoff frequency 5: 400 Hz, 3-pole *	$f_{C5(LPF)}$	380	400	420	Hz	(3,7,17)
100	Low-Pass Filter ($t_S = 16\mu s$) Cutoff frequency 8: 50 Hz, 4-pole *	$f_{C8(LPF)}$	47.5	50	52.5	Hz	(3,7,17)
101	Cutoff frequency 9: 150 Hz, 4-pole *	$f_{C9(LPF)}$	142.5	150	157.5	Hz	(3,7,17)
102	Cutoff frequency 10: 200 Hz, 4-pole *	$f_{C10(LPF)}$	190	200	210	Hz	(3,7,17)
103	Cutoff frequency 11: 400 Hz, 4-pole *	$f_{C11(LPF)}$	380	400	420	Hz	(3,7,17)
104	Cutoff frequency 12: 500 Hz, 4-pole *	$f_{C12(LPF)}$	475	500	525	Hz	(3,7,17)
105	Cutoff frequency 13: 200 Hz, 3-pole *	$f_{C13(LPF)}$	190	200	210	Hz	(3,7,17)
106	Offset Cancellation (Normal Mode, 12-Bit Output) Offset Averaging Period *	OFF_{AVEPER}	—	6.29146	—	s	(3,7)
107	Offset Slew Rate *	OFF_{SLEW}	—	0.2384	—	LSB/s	(3,7)
108	Offset Update Rate *	OFF_{RATE}	—	1049	—	ms	(3,7)
109	Offset Correction Value per Update Positive *	OFF_{CORRP}	—	0.25	—	LSB	(3,7)
110	Offset Correction Value per Update Negative *	OFF_{CORRN}	—	-0.25	—	LSB	(3,7)
111	Offset Correction Threshold Positive *	OFF_{THP}	—	0.125	—	LSB	(3,7)
112	Offset Correction Threshold Negative *	OFF_{THN}	—	0.125	—	LSB	(3,7)
113	Self Test Activation Time (\overline{CS} rising edge to 90% of ST Final Value) Cutoff frequency 0: 100 Hz, 4-pole	ST_ACT_{100}	—	—	7.00	ms	(19)
114	Cutoff frequency 1: 300 Hz, 4-pole	ST_ACT_{300}	—	—	3.00	ms	(19)
115	Cutoff frequency 2: 400 Hz, 4-pole	ST_ACT_{400}	—	—	2.50	ms	(19)
116	Cutoff frequency 3: 800 Hz, 4-pole	ST_ACT_{800}	—	—	1.70	ms	(19)
117	Cutoff frequency 4: 1000 Hz, 4-pole	ST_ACT_{1000}	—	—	1.60	ms	(19)
118	Cutoff frequency 5: 400 Hz, 3-pole	$ST_ACT_{400_3}$	—	—	2.40	ms	(19)
119	Offset Monitor Bypass Time after Self Test Deactivation	t_{ST_OMB}	—	320	—	t_S	(3,7)
120	Time Between Acceleration Data Requests (Same Axis)	t_{ACC_REQ}	15	—	—	μs	(3,7,20)
121	Arming Output Activation Time (ARM, $I_{ARM} = 200\mu A$) Moving Average and Count Arming Modes (2,3,4,5)	t_{ARM}	0	—	1.51	μs	(3,12)
122	Unfiltered Mode Activation Delay (Reference Figure 30)	$t_{ARM_UF_DLY}$	0	—	1.51	μs	(3,12)
123	Unfiltered Mode Arm Assertion Time (Reference Figure 30)	$t_{ARM_UF_ASSERT}$	5.00	—	6.579	μs	(3)
124	Sensing Element Natural Frequency	f_{gcell}	10791	13464	15879	Hz	(19)
125	Sensing Element Cutoff Frequency (-3 dB ref. to 0 Hz)	f_{gcell}	0.851	1.58	2.29	kHz	(19)
126	Sensing Element Damping Ratio	ζ_{gcell}	2.46	4.31	9.36	—	(19)
127	Sensing Element Delay (@100 Hz)	f_{gcell_delay}	70	101	187	μs	(19)
128	Sensing Element Step Response (0% - 90%)	t_{Step_gcell}	—	—	200	μs	(19)
129	Package Resonance Frequency	$f_{Package}$	100	—	—	kHz	(19)
130	Package Quality Factor	$Q_{Package}$	1	—	5		(19)

2.6 Dynamic Electrical Characteristics - Supply and SPI

$V_L \leq (V_{CC} - V_{SS}) \leq V_H$, $T_L \leq T_A \leq T_H$, $|\Delta T_A| < 25$ K/min unless otherwise specified

#	Characteristic	Symbol	Min	Typ	Max	Units	
131	Power-On Recovery Time ($V_{CC} = V_{CCMIN}$ to first SPI access)	t_{OP}	—	—	10	ms	(3)
132	Power-On Recovery Time (Internal POR to first SPI access)	t_{OP}	—	—	840	μ s	(3,7)
133	SPI Reset Activation Time (CS high to Reset)	t_{SPL_RESET}	—	—	300	ns	(7)
134	Internal Oscillator Frequency *	f_{OSC}	7.6	8	8.4	MHz	(7)
135	Test Frequency - Divided from Internal Oscillator	f_{OSCTST}	0.95	1	1.05	MHz	(1)
136	Serial Interface Timing (See Figure 7, $C_{MISO} \leq 80$ pF, $R_{MISO} \geq 10$ k Ω) Clock (SCLK) period (10% of V_{CC} to 10% of V_{CC}) *	t_{SCLK}	120	—	—	ns	(3)
137	Clock (SCLK) high time (90% of V_{CC} to 90% of V_{CC}) *	t_{SCLKH}	40	—	—	ns	(3)
138	Clock (SCLK) low time (10% of V_{CC} to 10% of V_{CC}) *	t_{SCLKL}	40	—	—	ns	(3)
139	Clock (SCLK) rise time (10% of V_{CC} to 90% of V_{CC})	t_{SCLKR}	—	15	40	ns	(19)
140	Clock (SCLK) fall time (90% of V_{CC} to 10% of V_{CC})	t_{SCLKF}	—	15	28	ns	(19)
141	\overline{CS} asserted to SCLK high ($\overline{CS} = 10\%$ of V_{CC} to SCLK = 10% of V_{CC})	t_{LEAD}	60	—	—	ns	(3)
142	\overline{CS} asserted to MISO valid ($\overline{CS} = 10\%$ of V_{CC} to MISO = 10/90% of V_{CC})	t_{ACCESS}	—	—	60	ns	(3)
143	Data setup time (MOSI = 10/90% of V_{CC} to SCLK = 10% of V_{CC}) *	t_{SETUP}	20	—	—	ns	(3)
144	MOSI Data hold time (SCLK = 90% of V_{CC} to MOSI = 10/90% of V_{CC}) *	t_{HOLD_IN}	10	—	—	ns	(3)
145	MISO Data hold time (SCLK = 90% of V_{CC} to MISO = 10/90% of V_{CC}) *	t_{HOLD_OUT}	0	—	—	ns	(3)
146	SCLK low to data valid (SCLK = 10% of V_{CC} to MISO = 10/90% of V_{CC}) *	t_{VALID}	—	—	35	ns	(3)
147	SCLK low to \overline{CS} high (SCLK = 10% of V_{CC} to $\overline{CS} = 90\%$ of V_{CC}) *	t_{LAG}	60	—	—	ns	(3)
148	\overline{CS} high to MISO disable ($\overline{CS} = 90\%$ of V_{CC} to MISO = Hi Z) *	$t_{DISABLE}$	—	—	60	ns	(3)
149	\overline{CS} high to \overline{CS} low ($\overline{CS} = 90\%$ of V_{CC} to $\overline{CS} = 90\%$ of V_{CC}) *	t_{CSN}	526	—	—	ns	(3)
150	SCLK low to \overline{CS} low (SCLK = 10% of V_{CC} to $\overline{CS} = 90\%$ of V_{CC}) *	t_{CLKCS}	50	—	—	ns	(3)
151	\overline{CS} high to SCLK high ($\overline{CS} = 90\%$ of V_{CC} to SCLK = 90% of V_{CC})	t_{CSCLK}	50	—	—	ns	(19)

1. Parameters tested 100% at final test.

2. Parameters tested 100% at wafer probe.

3. Parameters verified by characterization

4. (*) Indicates a critical characteristic.

5. Verified by qualification testing.

6. Parameters verified by pass/fail testing in production.

7. Functionality verified 100% via scan. Timing characteristic is directly determined by internal oscillator frequency.

8. N/A

9. Devices are trimmed at 100 Hz with 1000 Hz low-pass filter option selected. Response is corrected to 0 Hz response.

10. Low-pass filter cutoff frequencies shown are -3 dB referenced to 0 Hz response.

11. Power supply ripple at frequencies greater than 900 kHz should be minimized to the greatest extent possible.

12. Time from falling edge of \overline{CS} to ARM output valid

13. N/A

14. Thermal resistance between the die junction and the exposed pad; cold plate is attached to the exposed pad.

15. Device characterized at all values of V_L & V_H . Production test is conducted at all typical voltages (V_{TYP}) unless otherwise noted.

16. Data Path Latency is the signal latency from g-cell to SPI output disregarding filter group delays.

17. Filter characteristics are specified independently, and do not include g-cell frequency response.

18. Electrostatic Deflection Test completed during wafer probe.

19. Verified by Simulation.

20. Acceleration Data Request timing constraint only applies for proper operation of the Arming Function

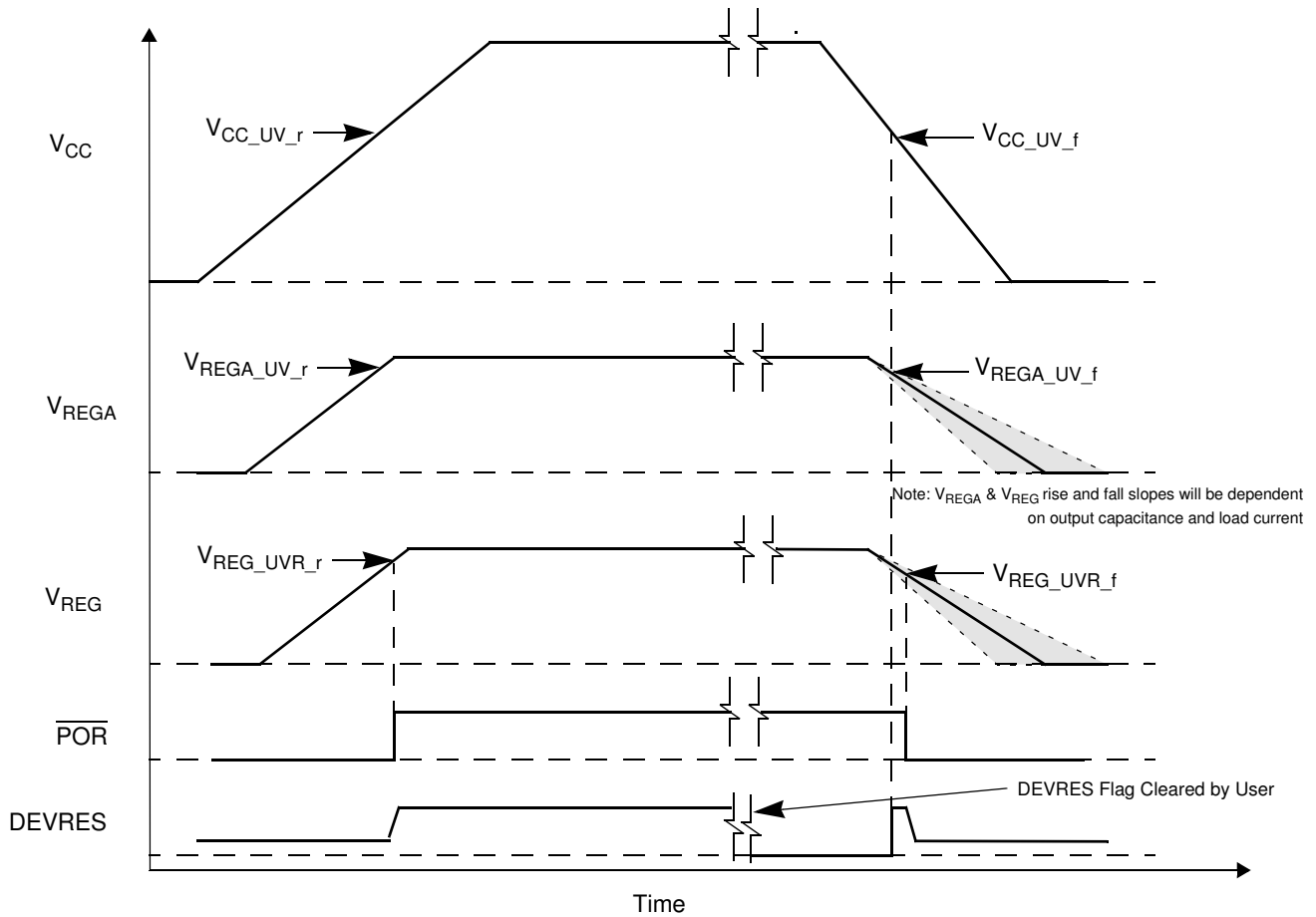

Figure 6. Power-Up Timing

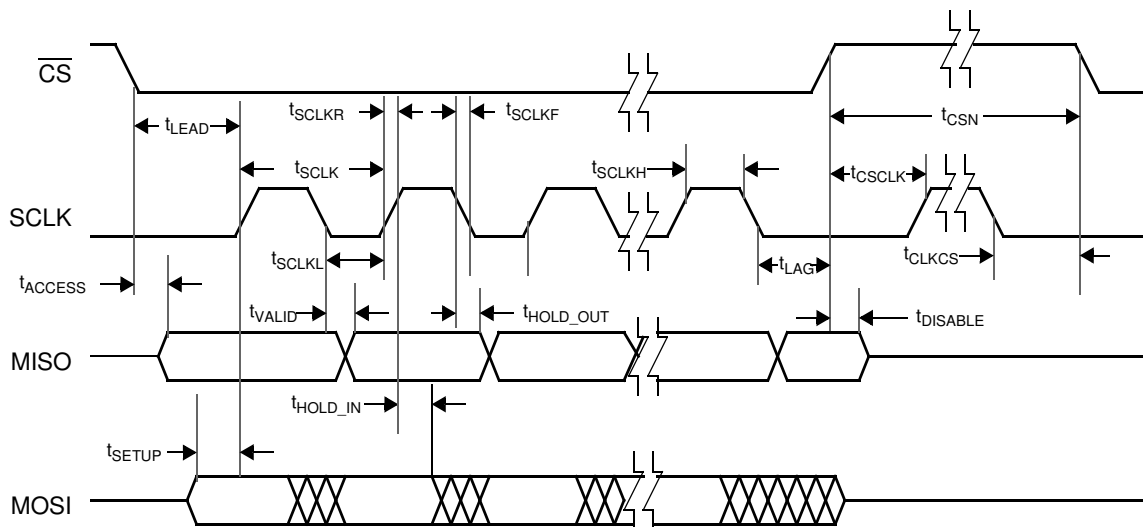

Figure 7. Serial Interface Timing

3 Functional Description

3.1 Customer Accessible Data Array

A customer accessible data array allows for each device to be customized. The array consists of an OTP factory programmable block and read/write registers for device programmability and status. The OTP and writable register blocks incorporate independent CRC circuitry for fault detection (reference [Section 3.2](#)). The writable register block includes a locking mechanism to prevent unintended changes during normal operation. Portions of the array are reserved for factory-programmed trim values. The customer accessible data is shown in the table below.

Table 3. Customer Accessible Data

Location		Bit Function								Type
Addr	Register	7	6	5	4	3	2	1	0	
\$00	SN0	SN[7]	SN[6]	SN[5]	SN[4]	SN[3]	SN[2]	SN[1]	SN[0]	F
\$01	SN1	SN[15]	SN[14]	SN[13]	SN[12]	SN[11]	SN[10]	SN[9]	SN[8]	
\$02	SN2	SN[23]	SN[22]	SN[21]	SN[20]	SN[19]	SN[18]	SN[17]	SN[16]	
\$03	SN3	SN[31]	SN[30]	SN[29]	SN[28]	SN[27]	SN[26]	SN[25]	SN[24]	
\$04	STDEFL	STDEFL[7]	STDEFL[6]	STDEFL[5]	STDEFL[4]	STDEFL[3]	STDEFL[2]	STDEFL[1]	STDEFL[0]	
\$05	Reserved	Reserved	Reserved	Reserved	Reserved	Reserved	Reserved	Reserved	Reserved	
\$06	FCTCFG	STMAG	0	0	0	0	0	0	0	
\$07	Invalid Address: "Invalid Register Request"									
\$08	PN	PN[7]	PN[6]	PN[5]	PN[4]	PN[3]	PN[2]	PN[1]	PN[0]	
\$09	Invalid Address: "Invalid Register Request"									
\$0A	DEVCTL	RES_1	RES_0	OCPHASE[1]	OCPHASE[0]	OFFCFG_EN	Reserved	Reserved	Reserved	R/W
\$0B	DEVCFG	OC	Reserved	ENDINIT	SD	OFMON	A_CFG[2]	A_CFG[1]	A_CFG[0]	
\$0C	AXISCFG	ST	Reserved	Reserved	Reserved	LPF[3]	LPF[2]	LPF[1]	LPF[0]	
\$0D	Invalid Address: "Invalid Register Request"									
\$0E	ARMCFG	Reserved	Reserved	APS[1]	APS[0]	AWS_N[1]	AWS_N[0]	AWS_P[1]	AWS_P[0]	
\$0F	Invalid Address: "Invalid Register Request"									
\$10	ARMT_P	AT_P[7]	AT_P[6]	AT_P[5]	AT_P[4]	AT_P[3]	AT_P[2]	AT_P[1]	AT_P[0]	
\$11	Invalid Address: "Invalid Register Request"									
\$12	ARMT_N	AT_N[7]	AT_N[6]	AT_N[5]	AT_N[4]	AT_N[3]	AT_N[2]	AT_N[1]	AT_N[0]	
\$13	Invalid Address: "Invalid Register Request"									
\$14	DEVSTAT	UNUSED	IDE	UNUSED	DEVINIT	MISOERR	0	OFFSET	DEVRES	R
\$15	COUNT	COUNT[7]	COUNT[6]	COUNT[5]	COUNT[4]	COUNT[3]	COUNT[2]	COUNT[1]	COUNT[0]	
\$16	OFFCORR	OFFCORR[7]	OFFCORR[6]	OFFCORR[5]	OFFCORR[4]	OFFCORR[3]	OFFCORR[2]	OFFCORR[1]	OFFCORR[0]	
\$17	Invalid Address: "Invalid Register Request"									
\$1C	Reserved	Reserved	Reserved	Reserved	Reserved	Reserved	Reserved	Reserved	Reserved	
\$1D	Reserved	Reserved	Reserved	Reserved	Reserved	Reserved	Reserved	Reserved	Reserved	

Type codes

F: Factory programmed OTP location
R: Read-only register

R/W: Read/write register
N/A: Not applicable

3.1.1 Device Serial Number Registers

A unique serial number is programmed into the serial number registers of each device during manufacturing. The serial number is composed of the following information:

Bit Range	Content
S12 - S0	Serial Number
S31 - S13	Lot Number

Serial numbers begin at 1 for all produced devices in each lot, and are sequentially assigned. Lot numbers begin at 1 and are sequentially assigned. No lot will contain more devices than can be uniquely identified by the 13-bit serial number. Depending on lot size and quantities, all possible lot numbers and serial numbers may not be assigned.

The serial number registers are included in the OTP shadow register array CRC verification. Reference [Section 3.2.1](#) for details regarding the CRC verification. Beyond this, the contents of the serial number registers have no impact on device operation or performance, and are only used for traceability purposes.

3.1.2 Self Test Deflection Register (STDEFL)

This read-only register provides the nominal self test deflection values at ambient temperature. The self test value is a positive deflection value, measured at the factory, and factory programmed for each device. The minimum stored value (\$00) equates to the minimum deflection specified in [Section 2.4](#) (ΔST_{MIN}), and the maximum stored value (\$FF) equates to the maximum deflection specified in [Section 2.4](#) (ΔST_{MAX}).

Table 4. Self Test Deflection Register

Location		Bit							
Address	Register	7	6	5	4	3	2	1	0
\$04	STDEFL	STDEFL[7]	STDEFL[6]	STDEFL[5]	STDEFL[4]	STDEFL[3]	STDEFL[2]	STDEFL[1]	STDEFL[0]

When self test is activated, the acceleration reading can be compared to the value in this register. The difference from the measured deflection value, and the nominal deflection value stored in the register shall not fall outside the self test accuracy limits specified in [Section 2.4](#) (ΔST_{ACC}). Reference [Section 3.6](#) for more details on calculating the self test Limits.

3.1.3 Factory Configuration Registers

The factory configuration register is a one time programmable, read only registers which contain customer specific device configuration information that is programmed by Freescale.

Table 5. Factory Configuration Register

Location		Bit							
Address	Register	7	6	5	4	3	2	1	0
\$06	FCTCFG	1	0	0	0	0	0	0	0

3.1.4 Part Number Register (PN)

The part number register is a one time programmable, read only register which contains two digits of the device part number to identify the axis and range information. The contents of this register have no impact on device operation or performance.

Table 6. Part Number Register

Location		Bit							
Address	Register	7	6	5	4	3	2	1	0
\$08	PN	PN[7]	PN[6]	PN[5]	PN[4]	PN[3]	PN[2]	PN[1]	PN[0]

PN Register Value		Range Section 2.4
Decimal	HEX	
255	\$FF	105
00	\$00	120

3.1.5 Device Control Register (DEVCTL)

The device control register is a read-write register which contains device control operations. The upper 2 bits of this register can be written during both initialization and normal operation. Bits 5 through 0 can be programmed during initialization and then are ignored once the ENDINIT bit is set.

Table 7. Device Control Register

Location		Bit							
Address	Register	7	6	5	4	3	2	1	0
\$0A	DEVCTL	RES_1	RES_0	OCPHASE[1]	OCPHASE[0]	OFFCFG_EN	Reserved	Reserved	Reserved
Reset Value		0	0	0	0	0	0	0	0

3.1.5.1 Reset Control (RES_1, RES_0)

A series of three consecutive register write operations to the reset control bits in the DEVCTL register will cause a device reset. To reset the internal digital circuitry, the following register write operations must be performed in the order shown below. The register write operations must be consecutive SPI commands in the order shown or the device will not be reset.

Register Write to DEVCTL	RES_1	RES_0	Effect
SPI Register Write 1	0	0	No Effect
SPI Register Write 2	1	1	No Effect
SPI Register Write 3	0	1	Device RESET

The response to the Register Write returns '0' for RES_1 and RES_0, and the existing register value bits 5 through 0. A Register Read of RES_1 and RES_0 returns '0' and terminates the reset sequence. If ENDINIT is cleared, the bits 2 through 0 in the DEVCTL register are modified as described in [Section 4.4](#). If ENDINIT is set, a Register Write will not modify bits 2 through 0 and the response to a Register Read or Write will include the last successful written values for these bits.

3.1.5.2 Offset Cancellation Phase Control Bits (OCPHASE[1:0])

The offset cancellation phase control bits control the offset cancellation start up phase. These bits can be written at any time ENDINIT is '0' if the OFFCFG_EN bit is set.

OFFCFG_EN	OCPHASE[1]	OCPHASE[0]	Writes to OCPHASE[1:0]	Offset Cancellation Phase
0	Don't Care	Don't Care	Ignored	Continues from the previously written phase (OCPHASE[1:0]) as specified in Section 3.8.4 .
1	0	0	Accepted	Remains in Start 1 until OFFCFG_EN is cleared or ENDINIT is set
1	0	1	Accepted	Remains in Start 2 until OFFCFG_EN is cleared or ENDINIT is set
1	1	0	Accepted	Remains in Start 3 until OFFCFG_EN is cleared or ENDINIT is set
1	1	1	Accepted	Remains in Normal Mode until OFFCFG_EN is cleared or ENDINIT is set

When ENDINIT is set, the OCPHASE[1:0] bits in a write command are ignored and the offset cancellation phase is set to "Normal". This can only be changed by a device reset. The response to a register read or write of the DEVCTL register once ENDINIT is set will return the last successfully written values of OCPHASE[1:0].

3.1.5.3 Offset Cancellation Configuration Enable Bit (OFFCFG_EN)

The offset cancellation phase configuration enable bit enables modification of the offset cancellation phase control bits (OCPHASE[1:0]) as shown in [Section 3.1.5.2](#)

When ENDINIT is set, the OFFCFG_EN bit in a write command is ignored, and the offset cancellation phase is set to "Normal". This can only be changed by a device reset. The response to a register read or write of the DEVCTL register once ENDINIT is set will return the last successfully written value of OFFCFG_EN.

3.1.5.4 Reserved Bits (DEVCTL[2:0])

Bits 2 through 0 of the DEVCTL register are reserved. A write to the reserved bits must always be logic '0' for normal device operation and performance.

3.1.6 Device Configuration Register (DEVCFG)

The device configuration register is a read/write register which contains data for general device configuration. The register can be written during initialization but is locked once the ENDINIT bit is set. This register is included in the writable register CRC check. Refer to [Section 3.2.2](#) for details.

Table 8. Device Configuration Register

Location		Bit							
Address	Register	7	6	5	4	3	2	1	0
\$0B	DEVCFG	OC	Reserved	ENDINIT	SD	OFMON	A_CFG[2]	A_CFG[1]	A_CFG[0]
Reset Value		0	0	0	0	0	0	0	0

3.1.6.1 Offset Cancelled Data Selection Bits (\overline{OC})

The Offset Cancelled Data Selection Bit determines whether the SPI transmitted data is raw data or offset cancelled data.

\overline{OC}	SPI Data
0	Offset Cancelled
1	Raw Data

If the \overline{OC} bit is cleared (Offset Cancelled Data), then the Offset Monitor is automatically enabled (OFMON = '1') regardless of the value written to DEVCFG[3].

3.1.6.2 Reserved Bit (Reserved)

Bits 6 of the DEVCFG register is reserved. A write to the reserved bit must always be logic '0' for normal device operation and performance.

3.1.6.3 End of Initialization Bit (ENDINIT)

The ENDINIT bit is a control bit used to indicate that the user has completed all device and system level initialization tests, and that the device will operate in normal mode. Once the ENDINIT bit is set, writes to all writable register bits are inhibited except for the DEVCTL register. Once written, the ENDINIT bit can only be cleared by a device reset. The writable register CRC check (reference [Section 3.2.2](#)) is only enabled when the ENDINIT bit is set.

When ENDINIT is set, the following occurs:

- Offset Cancellation is forced to normal mode. OCPHASE[1:0], and OFFCFG_EN remain in their previously set states.
- X-Axis Self Test is disabled. ST remains in its previously set state.

3.1.6.4 \overline{SD} Bit

The \overline{SD} bit determines the format of acceleration data results. If the \overline{SD} bit is set to a logic '1', unsigned results are transmitted, with the zero-g level represented by a nominal value of 512. If the \overline{SD} bit is cleared, signed results are transmitted, with the zero-g level represented by a nominal value of 0.

SD	Operating Mode
1	Unsigned Data Output
0	Signed Data Output

3.1.6.5 OFMON Bit

The OFMON bit determines if the offset monitor circuit is enabled. If the OFMON bit is set to a logic '1', the offset monitor is enabled. Reference [Section 3.8.5](#). If the OFMON bit is cleared, the offset monitor is disabled.

OFMON	Operating Mode
1	Offset Monitor Circuit Enabled
0	Offset Monitor Circuit Disabled

If the \overline{OC} bit in the DEVCFG register is cleared (Offset Cancelled Data), then the Offset Monitor is automatically enabled (OFMON = '1') regardless of the value written to DEVCFG[3].

3.1.6.6 ARM Configuration Bits (A_CFG[2:0])

The ARM Configuration Bits (A_CFG[2:0]) select the mode of operation for the ARM/PCM pins.

Table 9. Arming Output Configuration

A_CFG[2]	A_CFG[1]	A_CFG[0]	Operating Mode	Output Type	Reference
0	0	0	Arm Output Disabled	Hi Impedance	
0	0	1	PCM Output	Digital Output	Section 3.8.11
0	1	0	Moving Average Mode	Active High with Pulldown Current	Section 3.8.10.1
0	1	1	Moving Average Mode	Active Low with Pullup Current	Section 3.8.10.1
1	0	0	Count Mode	Active High with Pulldown Current	Section 3.8.10.2
1	0	1	Count Mode	Active Low with Pullup Current	Section 3.8.10.2
1	1	0	Unfiltered Mode	Active High with Pulldown Current	Section 3.8.10.3
1	1	1	Unfiltered Mode	Active Low with Pullup Current	Section 3.8.10.3

3.1.7 Axis Configuration Register (AXISCFG)

The axis configuration register is a read/write register which contain axis specific configuration information. This register can be written during initialization, but is locked once the ENDINIT bit is set. This registers is included in the writable register CRC check. Refer to [Section 3.2.2](#) for details.

Table 10. Axis Configuration Registers

Location		Bit							
Address	Register	7	6	5	4	3	2	1	0
\$0C	AXISCFG	ST	Reserved	Reserved	Reserved	LPF[3]	LPF[2]	LPF[1]	LPF[0]
Reset Value		0	0	0	0	0	0	0	0

3.1.7.1 Self Test Control (ST)

The ST bit enables and disables the self test circuitry. Self test circuitry is enabled if a logic '1' is written to ST and the ENDINIT bit has not been set. Enabling the self test circuitry results in a positive acceleration value. Self test deflection values are specified in [Section 2.4](#). ST is always cleared following internal reset.

When the self test circuitry is active, the offset cancellation block and the offset monitor status are suspended, and the status bits in the Acceleration Data Request Response will indicate "Self Test Active". Reference [Section 3.8.4](#) and [Section 4.2](#) for details. When the self test circuitry is disabled by clearing the ST bit, the offset monitor remains disabled until the time t_{ST_OMB} specified in [Section 2.5](#) expires. However, the status bits in the Acceleration Data Request Response will immediately indicate that self test is deactivated.

When ENDINIT is set, self test is disabled. This can only be changed by a reset. A Register Write will not modify the ST bit and the response to a Register Read or Write will include the last successful written values for these bits.

3.1.7.2 Reserved Bits (Reserved)

Bits 6 through 4 of the AXISCFG register are reserved. A write to the reserved bits must always be logic '0' for normal device operation and performance.

3.1.7.3 Low-Pass Filter Selection Bits (LPF[3:0])

The Low Pass Filter selection bit selects a low-pass filter as shown in [Table 11](#). Refer to [Section 3.8.3](#) for details regarding filter configurations.

Table 11. Low Pass Filter Selection Bits

LPF[3]	LPF[2]	LPF[1]	LPF[0]	Low Pass Filter Selected	Nominal Sample Rate (μ s)
0	0	0	0	100 Hz, 4-pole	8
0	0	0	1	300 Hz, 4-pole	8
0	0	1	0	400 Hz, 4-pole	8
0	0	1	1	800 Hz, 4-pole	8
0	1	0	0	1000 Hz, 4-pole	8
0	1	0	1	400 Hz, 3-pole	8
0	1	1	0	Reserved	Reserved
0	1	1	1	Reserved	Reserved
1	0	0	0	50 Hz, 4-pole	16
1	0	0	1	150 Hz, 4-pole	16
1	0	1	0	200 Hz, 4-pole	16
1	0	1	1	400 Hz, 4-pole	16
1	1	0	0	500 Hz, 4-pole	16
1	1	0	1	200 Hz, 3-pole	16
1	1	1	0	Reserved	Reserved
1	1	1	1	Reserved	Reserved

Note: Filter characteristics do not include g-cell frequency response.

3.1.8 Arming Configuration Registers (ARMCFG)

The arming configuration register contains configuration information for the arming function. The values in this register are only relevant if the arming function is operating in moving average mode, or count mode.

This register can be written during initialization but is locked once the ENDINIT bit is set. Refer to [Section 3.1.6.3](#). This register is included in the writable register CRC check. Refer to [Section 3.2.2](#) for details.

Table 12. Arming Configuration Register

Location		Bit							
Address	Register	7	6	5	4	3	2	1	0
\$0E	ARMCFG	Reserved	Reserved	APS[1]	APS[0]	AWS_N[1]	AWS_N[0]	AWS_P[1]	AWS_P[0]
Reset Value		0	0	0	0	1	1	1	1

3.1.9 Reserved Bits (Reserved)

Bits 7 through 6 of the ARMCFG register are reserved. A write to the reserved bits must always be logic '0' for normal device operation and performance.

3.1.9.1 Arming Pulse Stretch (APS[1:0])

The APS[1:0] bit sets the programmable pulse stretch time for the arming outputs. Refer to [Section 3.8.10](#) for more details regarding the arming function. Pulse stretch times are derived from the internal oscillator, so the tolerance on this oscillator applies.

Table 13. Arming Pulse Stretch Definitions

APS[1]	APS[0]	Pulse Stretch Time (Typical Oscillator)
0	0	0 ms
0	1	16.256 ms - 16.384 ms
1	0	65.408 ms - 65.536 ms
1	1	261.888 ms - 262.016 ms

3.1.9.2 Arming Window Size (AWS_x[1:0])

The AWS_x[1:0] bits have different functions depending on the state of the A_CFG bits in the DEVCFG register. If the arming function is set to moving average mode, the AWS bits set the number of acceleration samples used for the arming function moving average. The number of samples is set independently for each axis and polarity. If the arming function is set to count mode, the AWS bits set the sample count limit for the arming function. The sample count limit is set independently for each axis. Refer to [Section 3.8.10](#) for more details regarding the arming function.

Table 14. Positive Arming Window Size Definitions (Moving Average Mode)

AWS_P[1]	AWS_P[0]	Positive Window Size
0	0	2
0	1	4
1	0	8
1	1	16

Table 15. Negative Arming Window Size Definitions (Moving Average Mode)

AWS_N[1]	AWS_N[0]	Negative Window Size
0	0	2
0	1	4
1	0	8
1	1	16

Table 16. Arming Count Limit Definitions (Count Mode)

AWS_N[1]	AWS_N[0]	AWS_P[1]	AWS_P[0]	Sample Count Limit
Don't Care	Don't Care	0	0	1
Don't Care	Don't Care	0	1	3
Don't Care	Don't Care	1	0	7
Don't Care	Don't Care	1	1	15

3.1.10 Arming Threshold Registers (ARMT_P, ARMT_N)

The arming threshold registers contain the positive and negative thresholds to be used by the arming function. Refer to [Section 3.8.10](#) for more details regarding the arming function.

The arming threshold registers can be written during initialization but are locked once the ENDINIT bit is set. Refer to [Section 3.1.6.3](#). The arming threshold registers are included in the writable register CRC check. Refer to [Section 3.2.2](#) for details.

Table 17. Arming Threshold Registers

Location		Bit							
Address	Register	7	6	5	4	3	2	1	0
\$10	ARMT_P	AT_P[7]	AT_P[6]	AT_P[5]	AT_P[4]	AT_P[3]	AT_P[2]	AT_P[1]	AT_P[0]
\$12	ARMT_N	AT_N[7]	AT_N[6]	AT_N[5]	AT_N[4]	AT_N[3]	AT_N[2]	AT_N[1]	AT_N[0]
Reset Value		0	0	0	0	0	0	0	0

The values programmed into the threshold registers are the threshold values used for the arming function as described in [Section 3.8.10](#). The threshold registers hold independent unsigned 8-bit values for each axis and polarity. Each threshold increment is equivalent to one output LSB. [Table 18](#) shows examples of some threshold register values and the corresponding threshold.

Table 18. Threshold Register Value Examples

Axis Type		Programmed Thresholds		Positive Threshold (g)	Negative Threshold (g)
Range (g)	Sensitivity (LSB/g)	Positive (Decimal)	Negative (Decimal)		
105.5	18.2	100	50	5.50	-2.75
105.5	18.2	255	0	14.0	Disabled
105.5	18.2	50	20	2.75	-1.10
105.5	18.2	150	75	8.24	-4.12

If either the positive or negative threshold is programmed to \$00, comparisons are disabled for only that polarity. The arming function still operates for the opposite polarity. If both the positive and negative arming thresholds are programmed to \$00, the Arming function is disabled, and the output pin is disabled, regardless of the value of the A_CFG bits in the DEVCFG register.

3.1.11 Device Status Register (DEVSTAT)

The device status register is a read-only register. A read of this register clears the status flags affected by transient conditions. Reference [Section 4.5](#) for details on the response for each status condition.

Table 19. Device Status Register

Location		Bit							
Address	Register	7	6	5	4	3	2	1	0
\$14	DEVSTAT	UNUSED	IDE	UNUSED	DEVINIT	MISOERR	0	OFFSET	DEVRES

3.1.11.1 Unused Bits (UNUSED)

The unused bits have no impact on operation or performance. When read these bits may be '1' or '0'.

3.1.11.2 Internal Data Error Flag (IDE)

The internal data error flag is set if a customer or OTP register data CRC fault or other internal fault is detected as defined in [Section 4.5.5](#). The internal data error flag is cleared by a read of the DEVSTAT register. If the error is associated with a CRC fault in the writable register array, the fault will be re-asserted and will require a device reset to clear. If the error is associated with the data stored in the fuse array, the fault will be re-asserted even after a device reset.

3.1.11.3 Device Initialization Flag (DEVINIT)

The device initialization flag is set during the interval between negation of internal reset and completion of internal device initialization. DEVINIT is cleared automatically. The device initialization flag is not affected by a read of the DEVSTAT register.

3.1.11.4 SPI MISO Data Mismatch Error Flag (MISOERR)

The MISO data mismatch flag is set when a MISO Data mismatch fault occurs as specified in [Section 4.5.2](#). The MISOERR flag is cleared by a read of the DEVSTAT register.

3.1.11.5 Offset Monitor Error Flags (OFFSET)

The offset monitor error flag is set if the acceleration signal reaches the specified offset limit. The offset monitor error flags are cleared by a read of the DEVSTAT register.

3.1.11.6 Device Reset Flag (DEVRES)

The device reset flag is set during device initialization following a device reset. The device reset flag is cleared by a read of the DEVSTAT register.

3.1.12 Count Register (COUNT)

The count register is a read-only register which provides the current value of a free-running 8-bit counter derived from the primary oscillator. A 10-bit pre-scaler divides the primary oscillator frequency by 1024. Thus, the value in the register increases by one count every 128 μ s and the counter rolls over every 32.768 ms.

Table 20. Count Register

Location		Bit							
Address	Register	7	6	5	4	3	2	1	0
\$15	COUNT	COUNT[7]	COUNT[6]	COUNT[5]	COUNT[4]	COUNT[3]	COUNT[2]	COUNT[1]	COUNT[0]
Reset Value		0	0	0	0	0	0	0	0

3.1.13 Offset Correction Value Registers (OFFCORR)

The offset correction value register is a read-only register which contains the most recent offset correction increment / decrement value from the offset cancellation circuit. The value stored in this register indicate the amount of offset correction being applied to the SPI output data. The values has a resolution of 1 LSB.

Table 21. Offset Correction Value Register

Location		Bit							
Address	Register	7	6	5	4	3	2	1	0
\$16	OFFCORR	OFFCORR[7]	OFFCORR[6]	OFFCORR[5]	OFFCORR[4]	OFFCORR[3]	OFFCORR[2]	OFFCORR[1]	OFFCORR[0]
Reset Value		0	0	0	0	0	0	0	0

3.1.14 Reserved Registers (Reserved)

Registers \$1C and \$1D are reserved. A write to the reserved bits must always be logic '0' for normal device operation and performance.

Table 22. Reserved Registers

Location		Bit							
Address	Register	7	6	5	4	3	2	1	0
\$1C	Reserved	Reserved	Reserved	Reserved	Reserved	Reserved	Reserved	Reserved	Reserved
\$1D	Reserved	Reserved	Reserved	Reserved	Reserved	Reserved	Reserved	Reserved	Reserved
Reset Value		0	0	0	0	0	0	0	0

3.2 Customer Accessible Data Array CRC Verification

3.2.1 OTP Shadow Register Array CRC Verification

The OTP shadow register array is verified for errors using a 3-bit CRC. The CRC verification uses a generator polynomial of $g(x) = X^3 + X + 1$, with a seed value = '111'. If a CRC error is detected in the OTP array, the IDE bit is set in the DEVSTAT register.

3.2.2 Writable Register CRC Verification

The writable registers in the data array are verified for errors using a 3-bit CRC. The CRC verification is enabled only when the ENDINIT bit is set in the DEVCFG register. The CRC verification uses a generator polynomial of $g(x) = X^3 + X + 1$, with a seed value = '111'. If a CRC error is detected in the writable register array, the IDE bit is set in the DEVSTAT register.

3.3 Voltage Regulators

Separate internal voltage regulators supply the analog and digital circuitry. External filter capacitors are required, as shown in Figure 1. The voltage regulator module includes voltage monitoring circuitry which indicates a device reset until the external supply and all internal regulated voltages are within predetermined limits. A reference generator provides a stable voltage which is used by the $\Sigma\Delta$ converters.

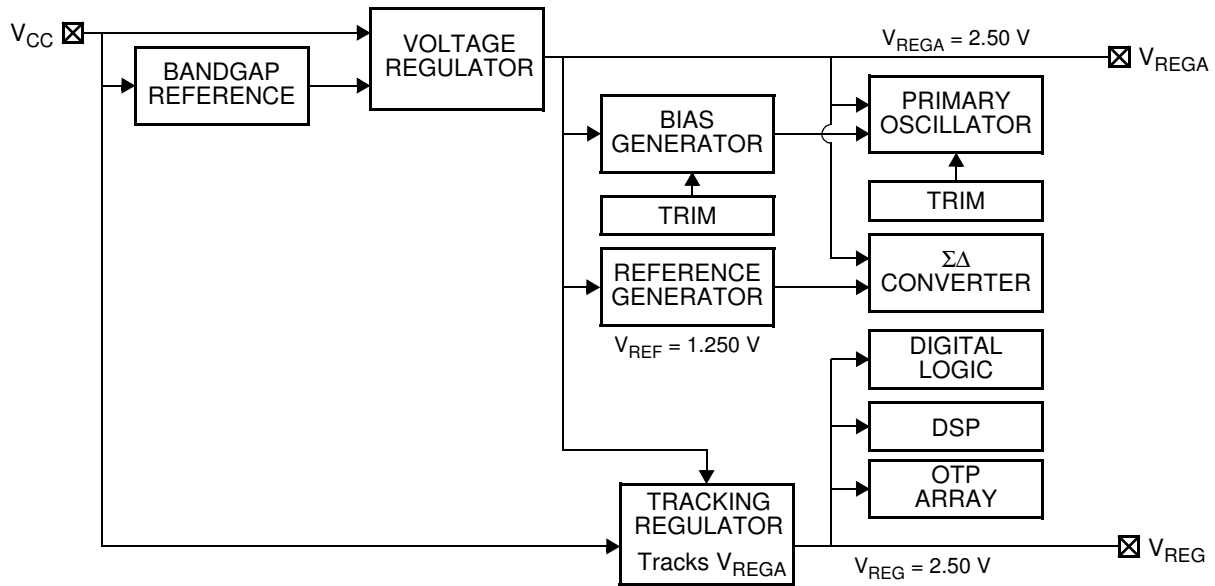

Figure 8. Power Supply Block Diagram

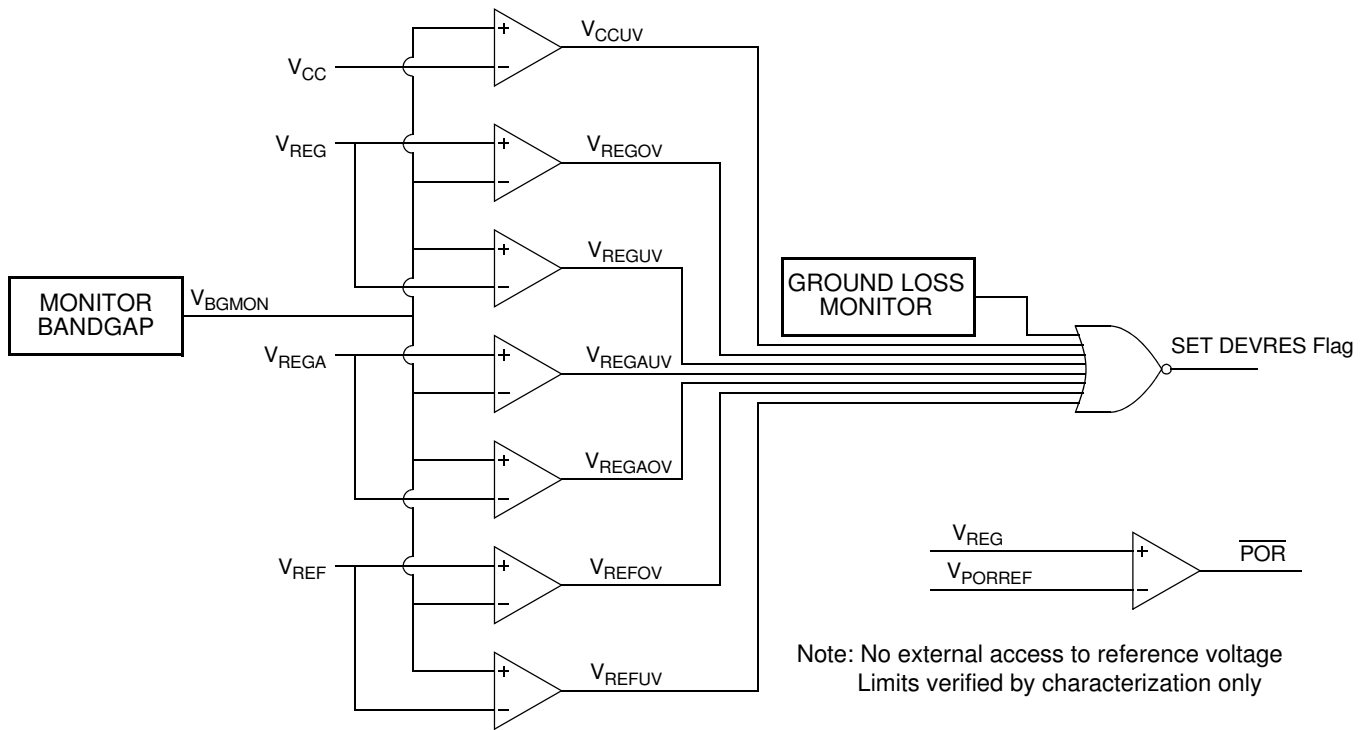

Figure 9. Voltage Monitoring

3.3.1 C_{VREG} Failure Detection

The digital supply voltage regulator is designed to be unstable with low capacitance. If the connection to the V_{REG} capacitor becomes open, the digital supply voltage will oscillate and cause either an undervoltage, or overvoltage failure within one internal sample time. This failure will result in one of the following:

1. The DEVRES flag in the DEVSTAT register will be set. The device will respond to SPI acceleration requests as defined in [Table 27](#).
2. The device will be held in RESET and be non-responsive to SPI requests.

3.3.2 C_{VREGA} Failure Detection

The analog supply voltage regulator is designed to be unstable with low capacitance. If the connection to the V_{REGA} capacitor becomes open, the analog supply voltage will oscillate and cause either an undervoltage, or overvoltage failure within one internal sample time. The DEVRES flag in the DEVSTAT register will be set. The device will respond to SPI acceleration requests as defined in [Table 27](#).

3.3.3 V_{SS} and V_{SSA} Ground Loss Monitor

The device detects the loss of ground connection to either V_{SS} or V_{SSA}. A loss of ground connection to V_{SS} will result in a V_{REG} overvoltage failure. A loss of ground connection to V_{SSA} will result in a V_{REG} undervoltage failure. Both failures result in a device reset.

3.3.4 SPI Initiated Reset

In addition to voltage monitoring, a device reset can be initiated by a specific series of three write operations involving the RES_1 and RES_0 bits in the DEVCTL register. Reference [Section 3.1.5.1](#) for details regarding the SPI initiated reset.

3.4 Internal Oscillator

The device includes a factory trimmed oscillator as specified in [Section 2.6](#).

3.4.1 Oscillator Monitor

The COUNT register in the customer accessible array is a read-only register which provides the current value of a free-running 8-bit counter derived from the primary oscillator. A 10-bit pre-scaler divides the primary oscillator by 1024. Thus, the value in the COUNT register increases by one count every 128 μs, and the register rolls over every 32.768 ms. The SPI master can periodically read the COUNT register, and verify the difference between subsequent register reads against the system time base.

1. The SPI access rates and deviations must be taken into account for this oscillator verification method.

3.5 Transducer

The transducer is an overdamped mass-spring-damper system described by the following transfer function:

$$H(s) = \frac{\omega_n^2}{s^2 + 2 \cdot \xi \cdot \omega_n \cdot s + \omega_n^2}$$

where:

ξ = Damping Ratio

ω_n = Natural Frequency = 2*π*f_n

Reference [Section 2.4](#) for transducer parameters.

3.6 Self Test Interface

When self test is enabled, the self test interface applies a voltage to the g-cell, causing a deflection of the proof mass. Once enabled, offset cancellation is suspended and the deflection results in an acceleration which is superimposed upon the input acceleration.

The resulting acceleration readings can be compared either against absolute limits, or the values stored in the Self Test Deflection Registers (Reference [Section 3.1.2](#)). The self test interface is controlled through SPI write operations to the DEVCFG register described in [Section 3.1.7](#) only if the ENDINIT bit in the DEVCFG register is cleared. A diagram of the self test interface is shown in [Figure 10](#).

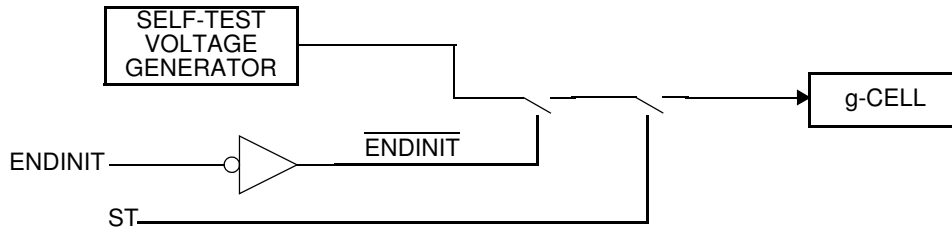

Figure 10. Self Test Interface

3.6.1 Raw Self Test Deflection Verification

The raw self test deflection can be directly verified against raw self test limits listed in [Section 2.4](#).

3.6.2 Delta Self Test Deflection Verification

The raw self test deflection can be verified against the ambient temperature self test deflection value recorded at the time the device was produced. The production self test deflection is stored in the STDEFL register such that the minimum stored value (0x00) is equivalent to ΔST_{MIN} , and the maximum stored value (0xFF) is equivalent to ΔST_{MAX} . The Delta Self Test Deflection limits can then be determined by the following equations:

$$\Delta ST_{ACCMINLIMIT} = FLOOR \cdot \left[\left(\Delta ST_{MIN} + \left[\frac{\Delta STDEFLx_{CNTS}}{255} \right] \times [\Delta ST_{MAX} - \Delta ST_{MIN}] \right) \times (1 - \Delta ST_{ACC}) \right]$$

$$\Delta ST_{ACCMAXLIMIT} = CEIL \cdot \left[\left(\Delta ST_{MIN} + \left[\frac{\Delta STDEFLx_{CNTS}}{255} \right] \times [\Delta ST_{MAX} - \Delta ST_{MIN}] \right) \times (1 + \Delta ST_{ACC}) \right]$$

where:

- ΔST_{ACC} The accuracy of the self test deflection relative to the stored deflection as specified in [Section 2.4](#).
- $\Delta STDEFLx_{CNTS}$ The value stored in the STDEFL register.
- ΔST_{MIN} The minimum self test deflection at 25C as specified in [Section 2.4](#).
- ΔST_{MAX} The maximum self test deflection at 25C as specified in [Section 2.4](#).

3.7 $\Sigma\Delta$ Converter

A sigma delta converter provides the interface between the transducer and the DSP. The output of the $\Sigma\Delta$ converter is a data stream at a nominal frequency of 1 MHz.

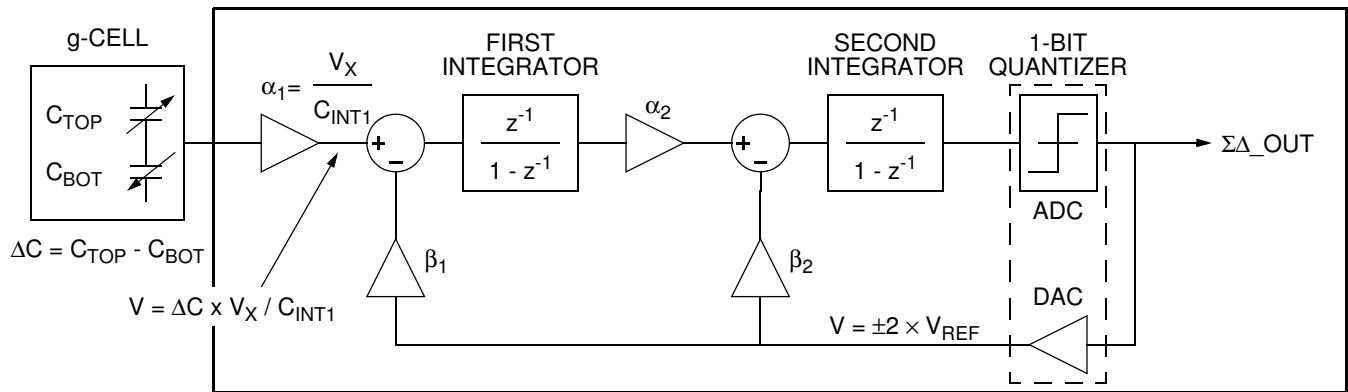

Figure 11. $\Sigma\Delta$ Converter Block Diagram

3.8 Digital Signal Processing Block

A digital signal processing (DSP) block is used to perform signal filtering and compensation operations. A diagram illustrating the signal processing flow is shown in Figure 12.

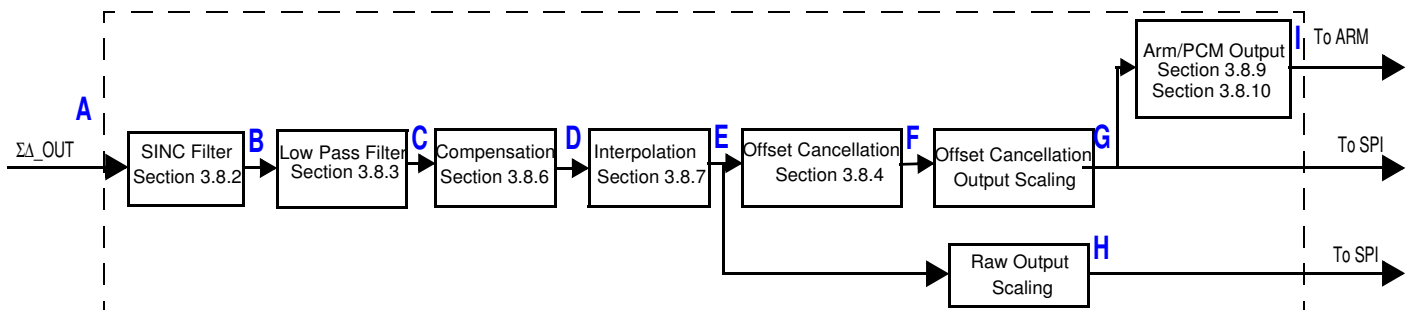

Figure 12. Signal Chain Diagram

Table 23. Signal Chain Characteristics

	Description	Sample Time (μs)	Data Width Bits	Over Range Bits	Effective Bits	Rounding Resolution Bits	Typical Block Latency	Reference
A	SD	1	1		1		3.2 μs	Section 3.7
B	SINC Filter	8	14		13		11.2 μs	Section 3.8.2
C	Low Pass Filter	8/16	20	4	12	4	Reference Section 3.8.3	Section 3.8.3
D	Compensation	8/16	20	4	12	4	7.875 μs	Section 3.8.6
E	Interpolation	4/8	20	4	12	4	$t_s / 2$	Section 3.8.8
F	Offset Cancellation	256	20	4	12	4	N/A	Section 3.8.4
GH	SPI Output	4/8	—	—	12	—	$t_s / 2$	
I	PCM Output	4/8	—	—	9	—		Section 3.8.11

3.8.1 DSP Clock

The DSP is clocked at 8 MHz, with an effective 6 MHz operating frequency. The clock to the DSP is disabled for 1 clock prior to each edge of the $\Sigma\Delta$ modulator clock to minimize noise during data conversion.

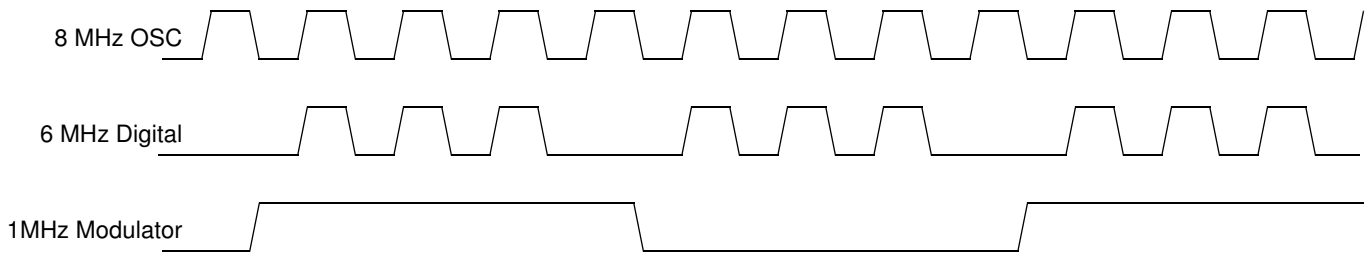

Figure 13. Clock Generation

3.8.2 Decimation Sinc Filter

The serial data stream produced by the $\Sigma\Delta$ converter is decimated and converted to parallel values by a 3rd order 16:1 sinc filter with a decimation factor of 8 or 16, depending on the Low Pass Filter selected.

$$H(z) = \left[\frac{1 - z^{-16}}{16 \times (1 - z^{-1})} \right]^3$$

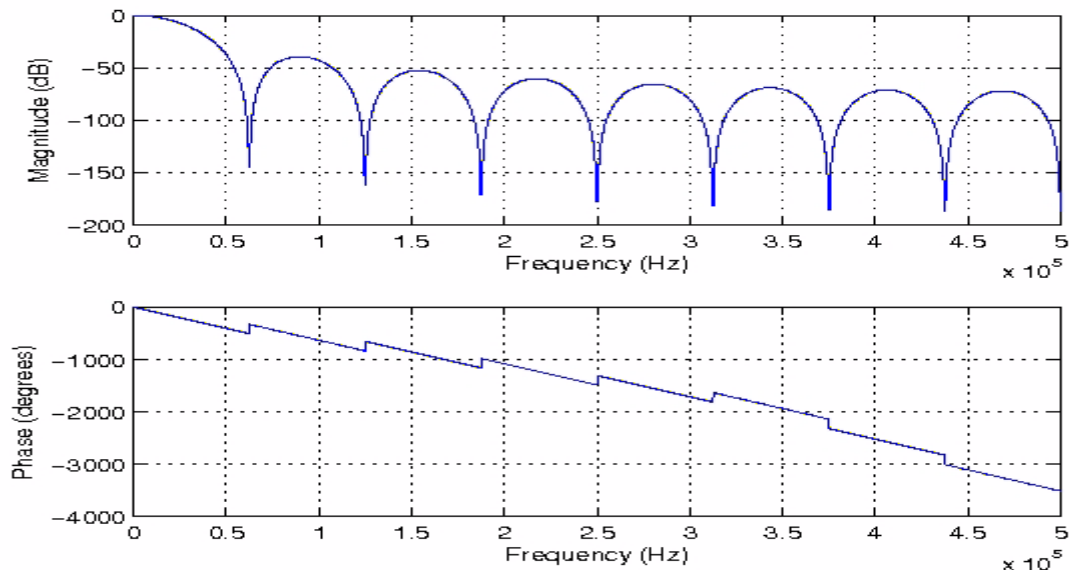

Figure 14. Sinc Filter Response, $t_S = 8 \mu s$

3.8.3 Low Pass Filter

Data from the Sinc filter is processed by an infinite impulse response (IIR) low pass filter.

$$H(z) = \frac{n_0 + (n_1 \cdot z^{-1}) + (n_2 \cdot z^{-2}) + (n_3 \cdot z^{-3}) + (n_4 \cdot z^{-4})}{d_0 + (d_1 \cdot z^{-1}) + (d_2 \cdot z^{-2}) + (d_3 \cdot z^{-3}) + (d_4 \cdot z^{-4})}$$

The device provides the option for one of twelve low-pass filters. The filter is selected with the LPF[3:0] bits in the AXISCFG register. The filter selection options are listed in [Section 3.1.7.3](#), [Table 11](#). Response parameters for the low-pass filter are specified in [Section 2.4](#). Filter characteristics are illustrated in the figures on the following pages.

Table 24. Low Pass Filter Coefficients

Filter Number	LPF Value (HEX)	Description -3dB Frequency (±5%)	Filter Order	Sample Time (µs ±5%)	Filter Coefficients				Group Delay	Self Test Step Response (ms)		
					n ₀	n ₁	n ₂	n ₃			d ₀	d ₁
8	0x08	50 Hz LPF	4	16	n ₀	2.08729034056887e-10	d ₀	1			26816/f _{osc}	14.00
					n ₁	8.349134489240434e-10	d ₁	-3.976249694824219				
					n ₂	1.25237777794924e-09	d ₂	5.929003009577855				
0	0x00	100 Hz LPF	4	8	n ₃	8.349103355433541e-10	d ₃	-3.929255528257727			7.00	
					n ₄	2.087307211059861e-10	d ₄	0.9765022168437554				
9	0x09	150 Hz LPF	4	16	n ₀	1.639127731323242e-08	d ₀	1			9024/f _{osc}	6.00
					n ₁	6.556510925292969e-08	d ₁	-3.928921222686768				
					n ₂	9.834768482194806e-08	d ₂	5.789028996785419				
1	0x01	300 Hz LPF	4	8	n ₃	6.556510372902331e-08	d ₃	-3.791257019240902			3.00	
					n ₄	1.639128257923422e-08	d ₄	0.9311495074496179				
10	0x0A	200 Hz LPF	4	16	n ₀	5.124509334564209e-08	d ₀	1			6784/f _{osc}	5.00
					n ₁	2.049803733825684e-07	d ₁	-3.905343055725098				
					n ₂	3.074705789151505e-07	d ₂	5.72004239520561				
2	0x02	400 Hz LPF	4	8	n ₃	2.049803958150164e-07	d ₃	-3.723967810019985			2.50	
					n ₄	5.124510693742625e-08	d ₄	0.9092692903507213				
13	0x0D	200 Hz LPF	3	16	n ₀	2.720393240451813e-06	d ₀	1			5632/f _{osc}	4.80
					n ₁	8.161179721355438e-06	d ₁	-2.931681632995605				
					n ₂	8.161180123840722e-06	d ₂	2.865296718275204				
5	0x05	400 Hz LPF	3	8	n ₃	2.720393634345496e-06	d ₃	-0.9335933215174919			2.40	
					n ₄	0	d ₄	0				
11	0x0B	400 Hz LPF	4	16	n ₀	7.822513580322266e-07	d ₀	1			3392/f _{osc}	2.50
					n ₁	3.129005432128906e-06	d ₁	-3.811614513397217				
					n ₂	4.693508163398543e-06	d ₂	5.450666051045118				
3	0x03	800 Hz LPF	4	8	n ₃	3.129005428784364e-06	d ₃	-3.465805771100349			1.70	
					n ₄	7.822513604678875e-07	d ₄	0.8267667478030489				
12	0x0C	500 Hz LPF	4	16	n ₀	1.865386962890625e-06	d ₀	1			2688/f _{osc}	3.20
					n ₁	7.4615478515625e-06	d ₁	-3.765105724334717				
					n ₂	1.119232176112846e-05	d ₂	5.319861050818872				
4	0x04	1000 Hz LPF	4	8	n ₃	7.4615478515625e-06	d ₃	-3.34309015036024			1.60	
					n ₄	1.86538696264658e-06	d ₄	0.7883646729233078				

Note: Low Pass Filter figures do not include g-cell frequency response.

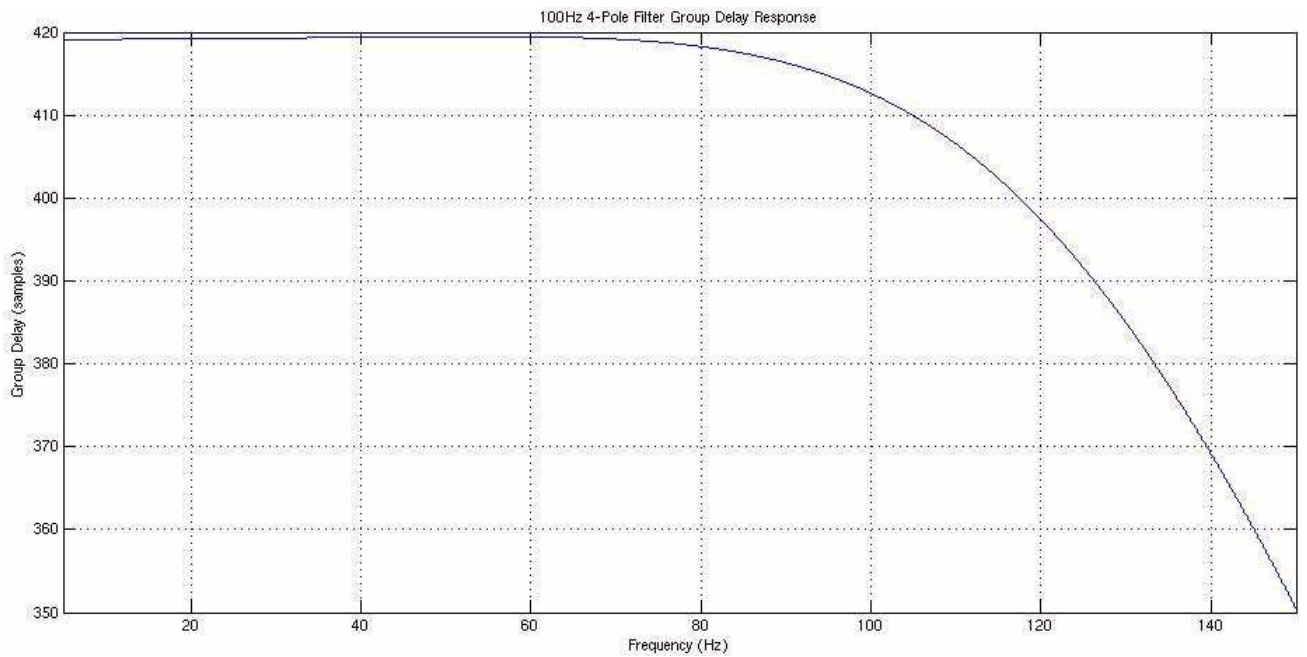
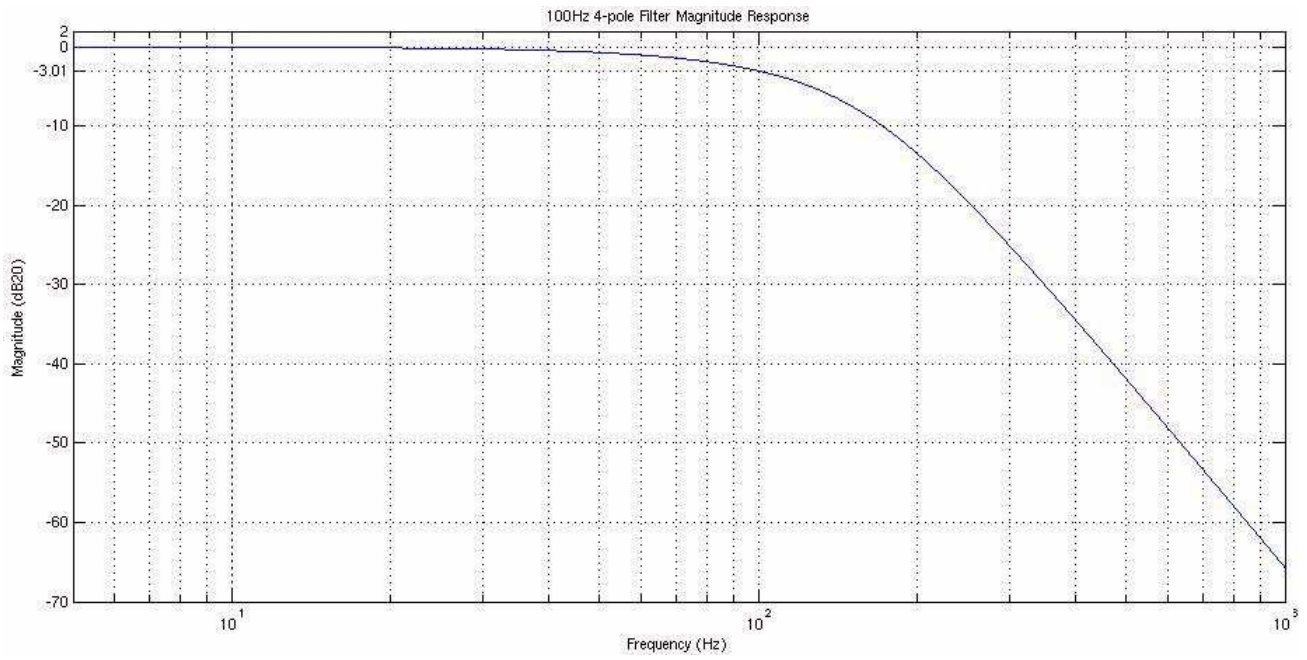

Figure 15. Low-Pass Filter Characteristics: $f_C = 100$ Hz, Poles = 4, $t_S = 8$ μ s

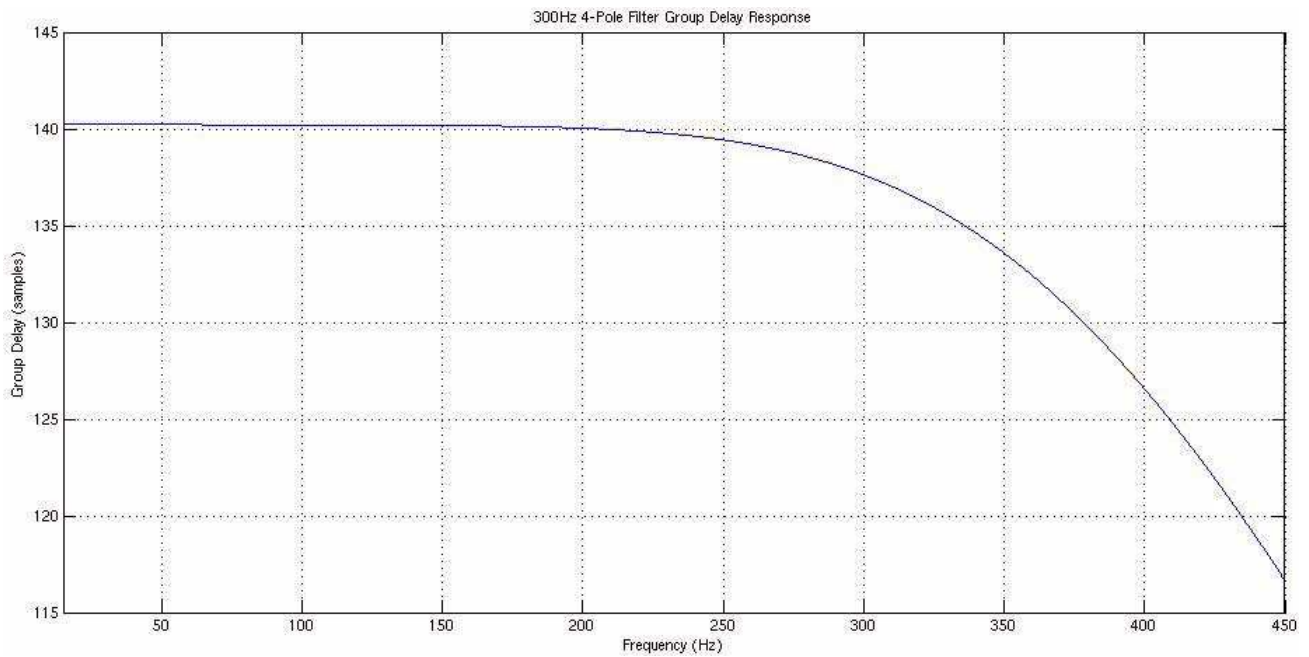
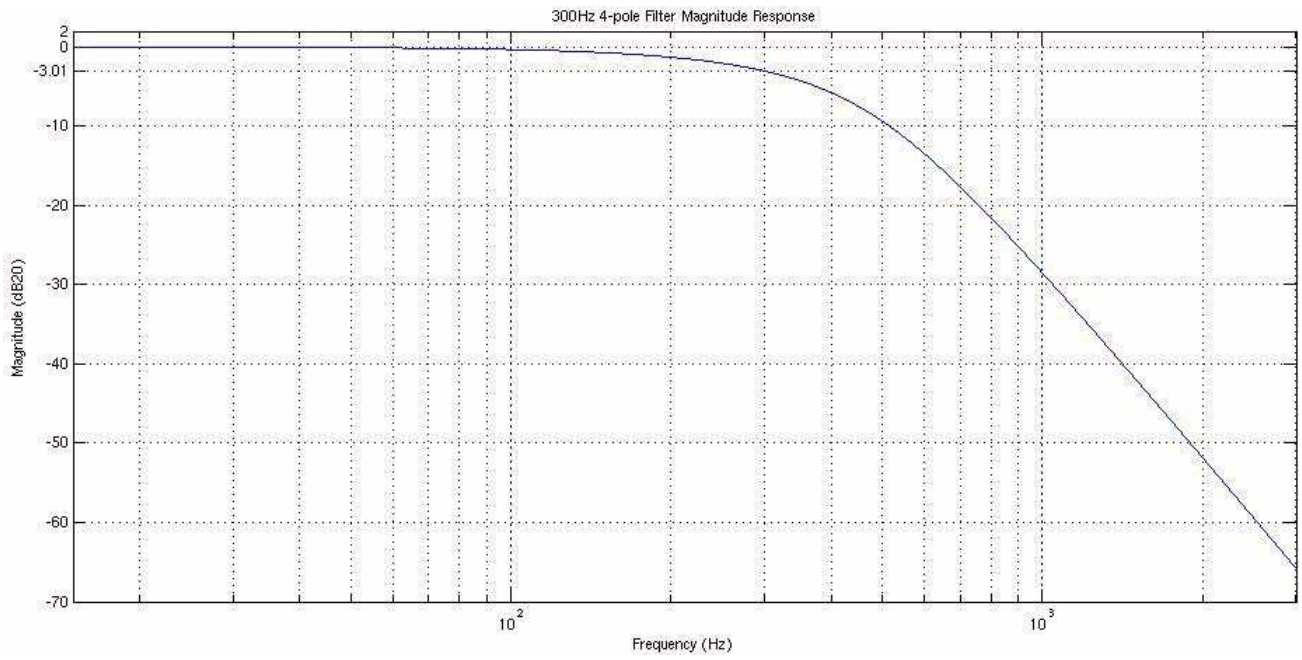

Figure 16. Low-Pass Filter Characteristics: $f_c = 300$ Hz, Poles = 4, $t_s = 8 \mu s$

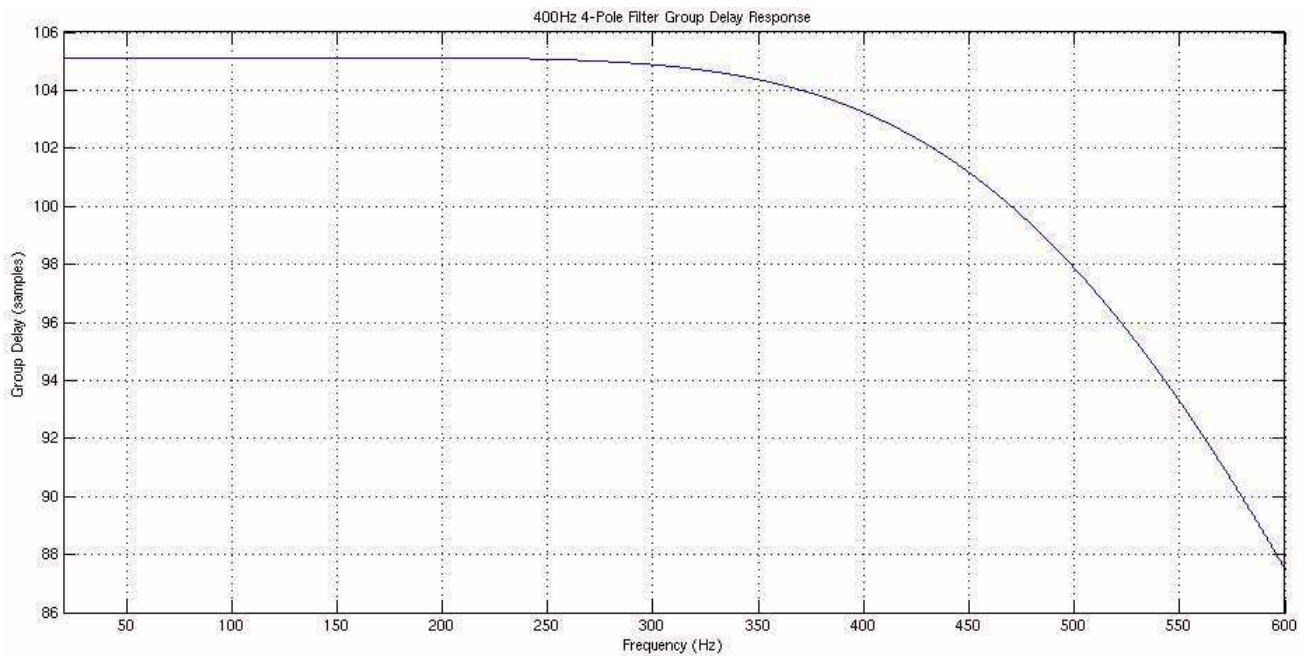
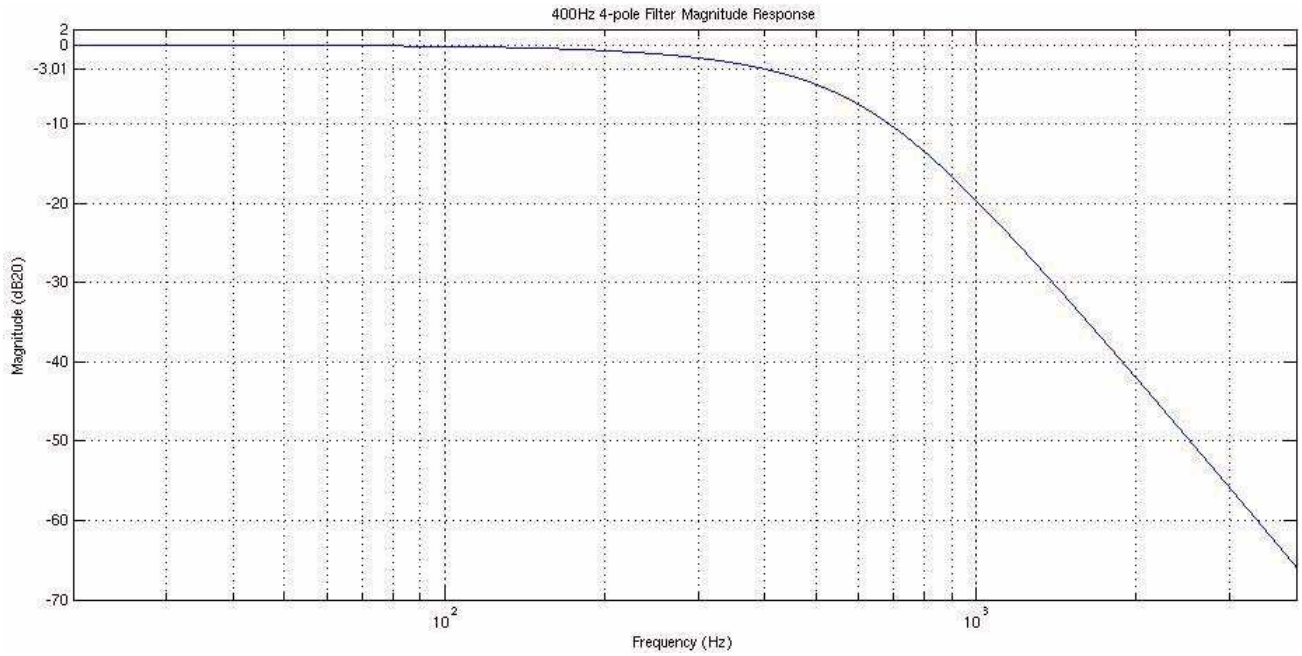

Figure 17. Low-Pass Filter Characteristics: $f_C = 400$ Hz, Poles = 4, $t_S = 8 \mu s$

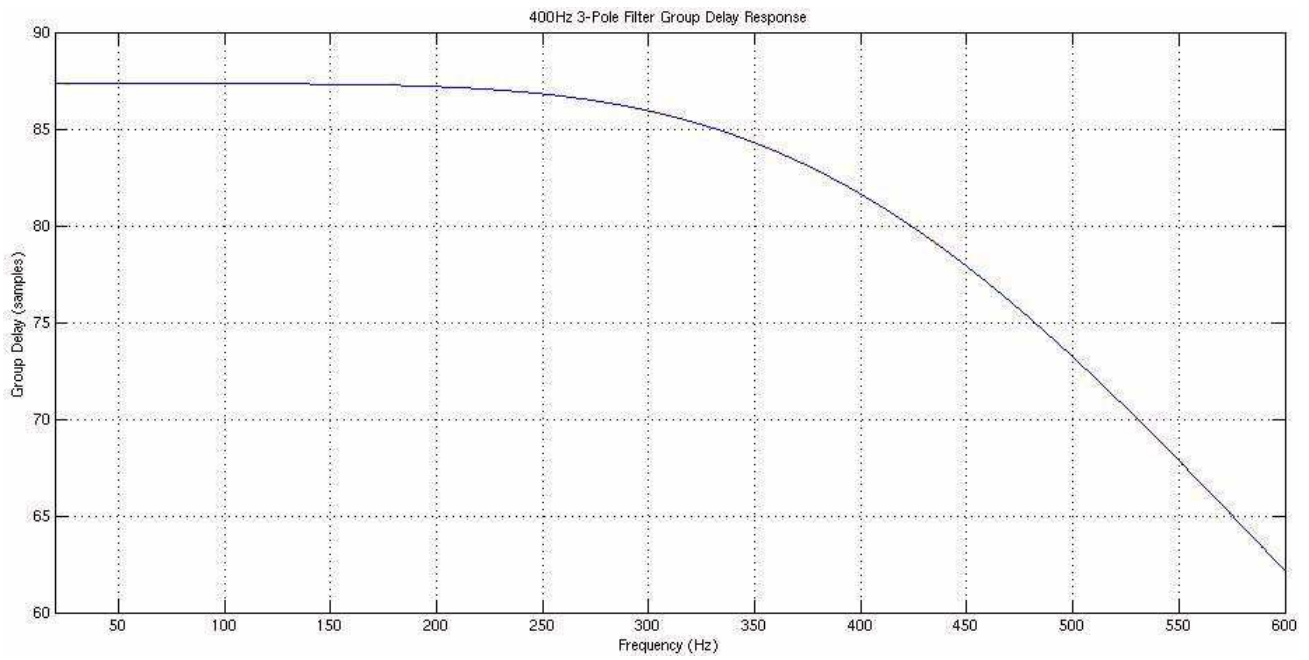
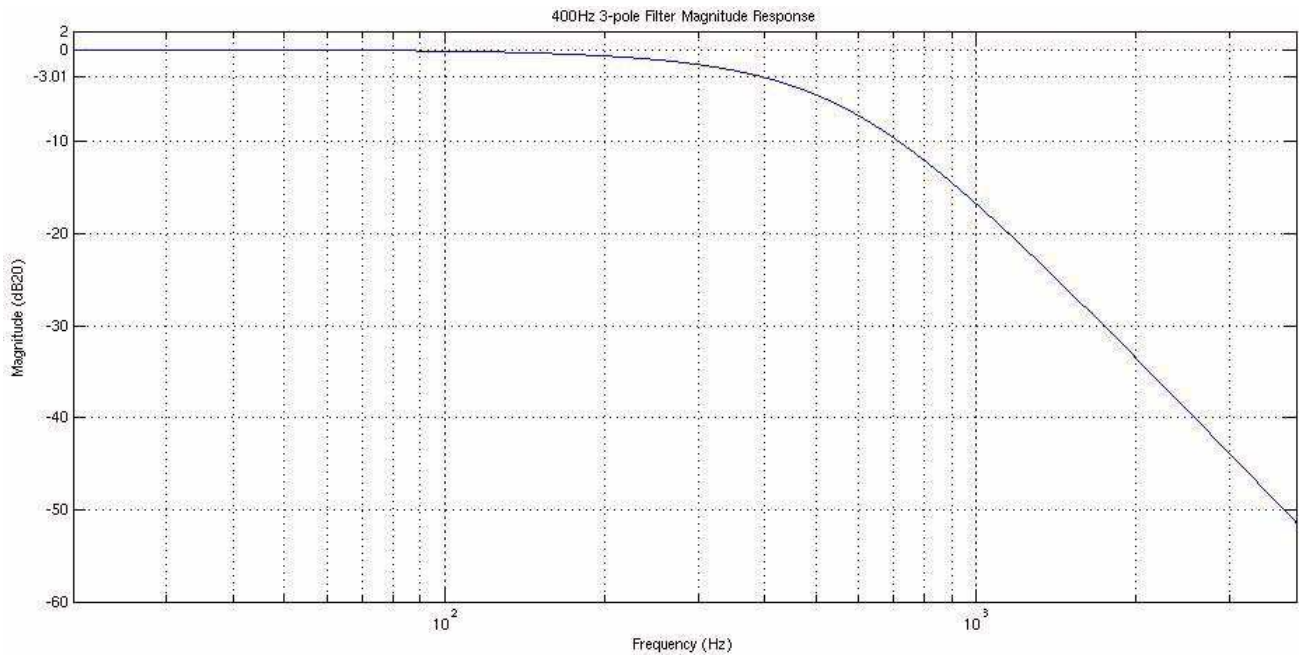

Figure 18. Low-Pass Filter Characteristics: $f_C = 400$ Hz, Poles = 3, $t_S = 8 \mu s$

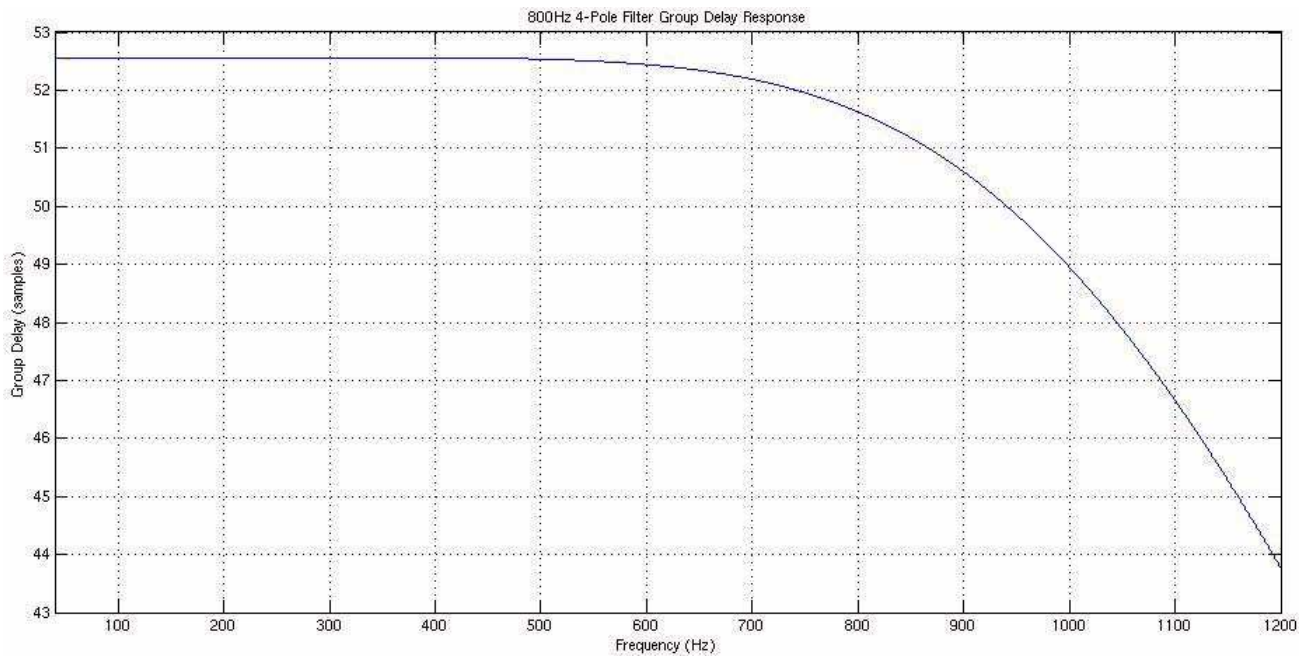
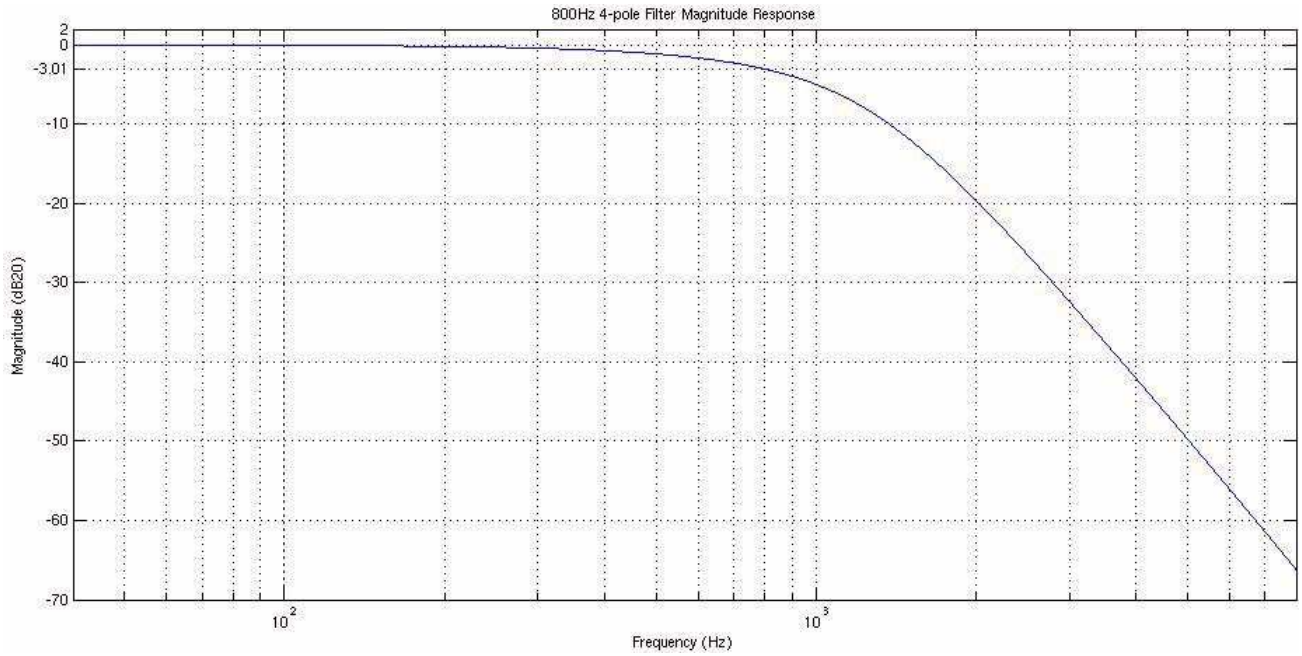

Figure 19. Low-Pass Filter Characteristics: $f_c = 800$ Hz, Poles = 4, $t_s = 8 \mu s$

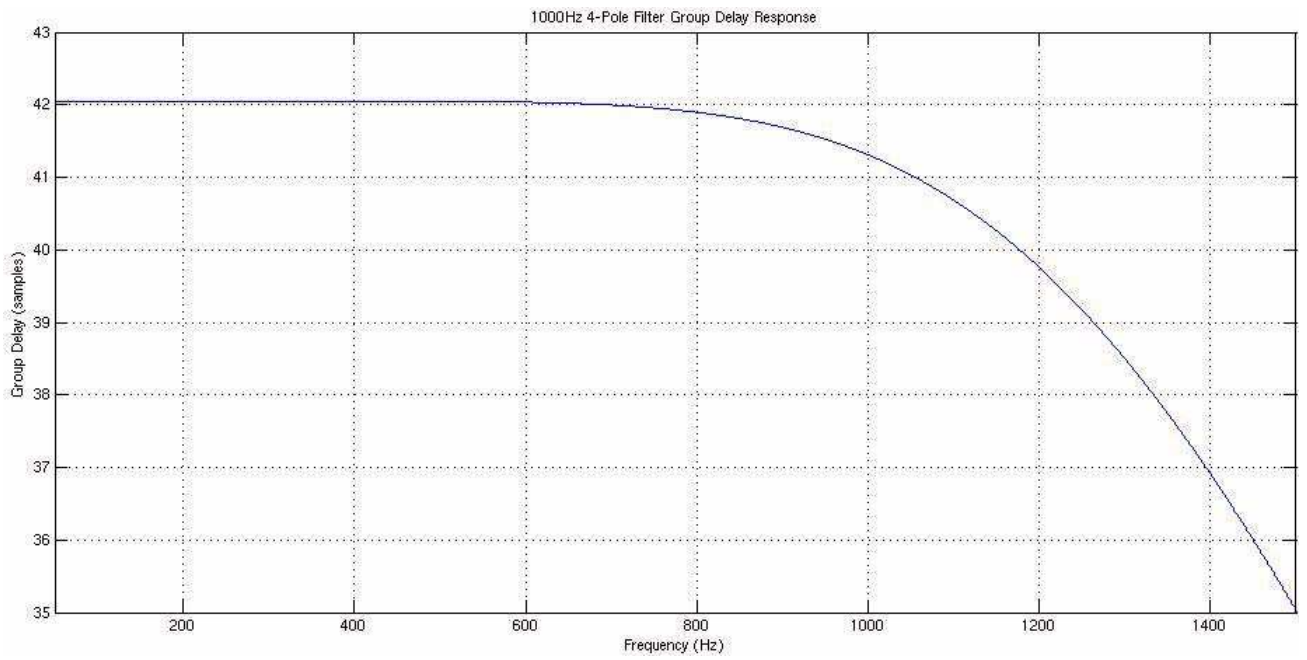
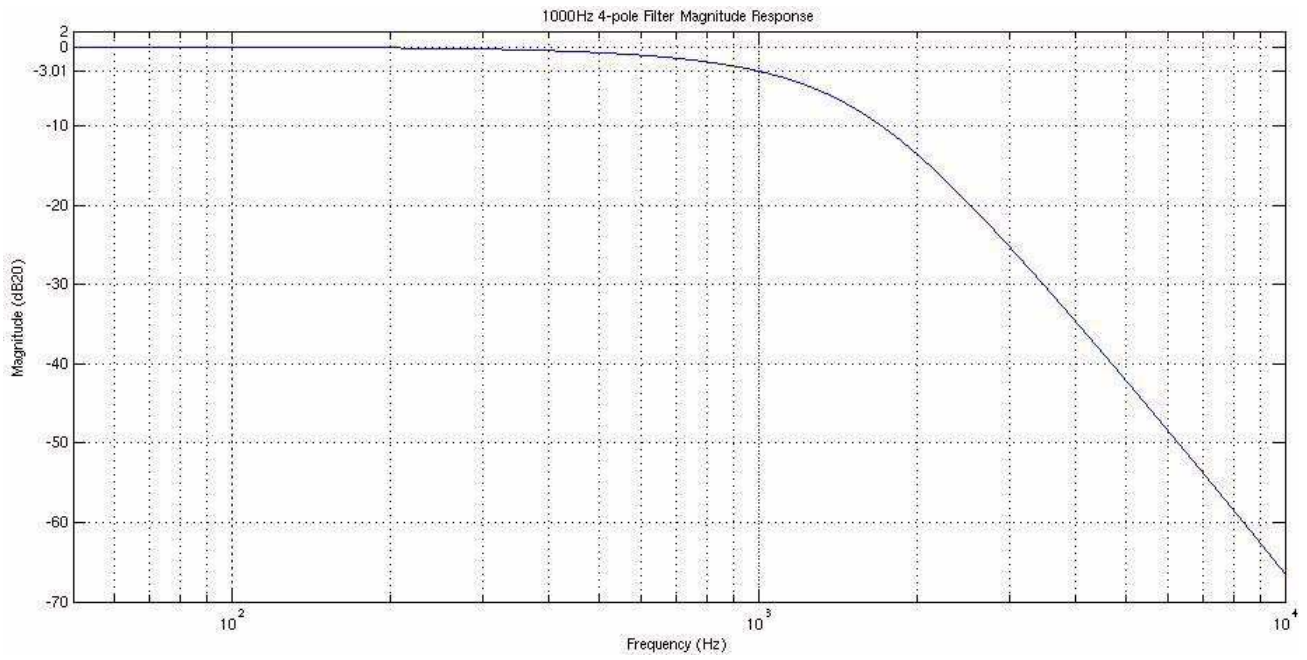

Figure 20. Low-Pass Filter Characteristics: $f_c = 1000$ Hz, Poles = 4, $t_s = 8 \mu s$

3.8.4 Offset Cancellation

The device provides the option to read offset cancelled acceleration data via the SPI by clearing the \overline{OC} bit in the DEVCFG register (reference Section 3.1.6.1) and in the SPI command (reference Section 4.1). A block diagram of the offset cancellation is shown in Figure 21, and response parameters are specified in Section 2.4 and in Table 25.

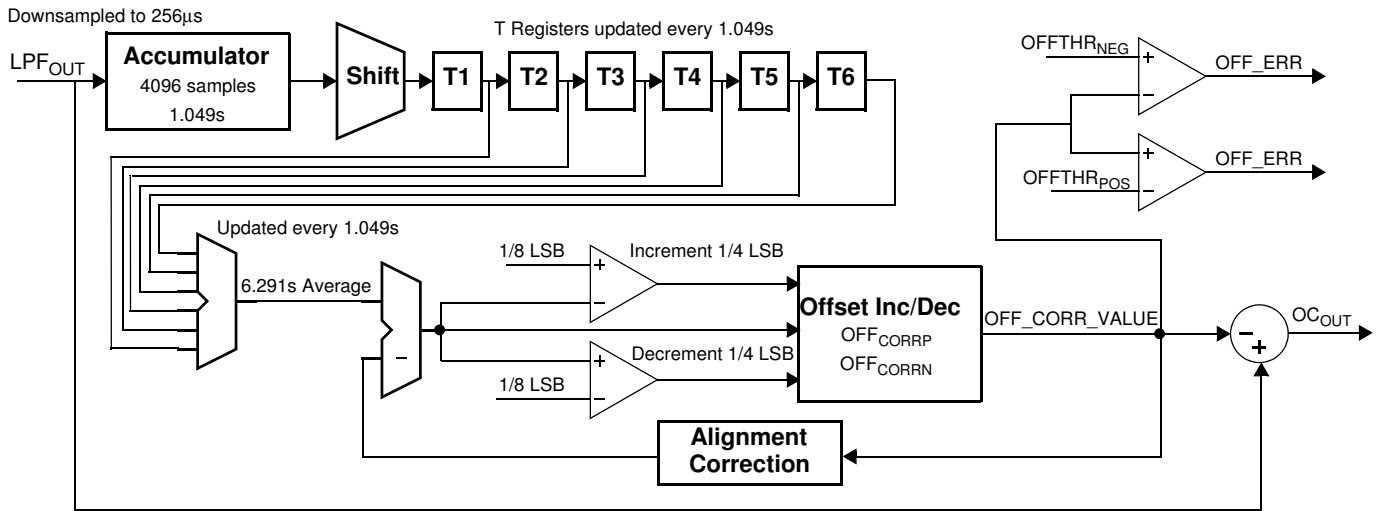

Figure 21. Offset Cancellation Block Diagram

In normal operation, the offset cancellation circuit computes a 24,576 sample running average of the acceleration data downsampled to 256 μ s. The running average is compared against positive and negative thresholds to determine the offset correction value that will be applied to the acceleration data.

During start up, three phases of moving average sizes are used to allow for faster convergence of misuse input signals. Reference Table 25 for offset cancellation timing information during startup and normal operation. The offset cancellation startup phase can also be directly controlled during initialization (ENDINIT = '0') using the OCPHASE[1:0] bits and the OFFCFG_EN bit in the DEVCTL register, as described in Section 3.1.5.2 and Section 3.1.5.3.

Table 25. Offset Cancellation Timing Specifications

Phase	Start Time of Phase (from POR)	Typical Time in Phase (ms)	# of Samples in Phase	Samples Averaged	OFF_CORR_VALUE Update Rate (ms)	Averaging Period (ms)	Maximum Slew Rate (LSB/s)	Averaging Filter -3dB Frequency (Hz)
Start 1	t_{OP}	524.288	2048	48	2.048	12.288	122.1	36.05
Start 2	$t_{OP} + 524.288$	524.288	2048	384	16.38	98.304	15.26	4.506
Start 3	$t_{OP} + 1048.576$	524.288	2048	3072	131.1	786.432	1.907	0.5632
Normal	$t_{OP} + 1572.864$	—	—	24576	1049	6291.456	0.2384	0.07040

When the self test circuitry is active, the offset cancellation block and the offset monitor block are suspended, and the offset correction value is constant. Once the self test circuitry is disabled, the offset cancellation block remains suspended for the time t_{ST_OMB} to allow the acceleration output to return to its nominal offset.

3.8.5 Offset Monitor

The device provides the option for an offset monitor circuit. The offset monitor circuit is enabled when the OFMON bit in the DEVCFG register is programmed to a logic '1'. The output of the offset cancellation circuit is compared against a high and low threshold. If the offset correction value exceeds either the OFFTHR_POS, or OFFTHR_NEG threshold, an Offset Over Range Error condition is indicated.

The offset correction value update rate is listed in Table 25: "Maximum Slew Rate". Because the offset monitor uses this value, the offset monitor will also update at this rate. The time to indicate an Offset Over Range Error is dependent upon the input signal.

The offset monitor status remains suspended during self test, because the offset monitor is based on the offset cancellation circuit, which is also suspended during self test. The offset monitor is disabled for 2.1 seconds following reset regardless of the state of the OFMON bit.

3.8.6 Signal Compensation

The device includes internal OTP and signal processing to compensate for sensitivity error and offset error. This compensation is necessary to achieve the specified parameters in [Section 2.4](#).

3.8.7 Output Scaling

The 20 bit digital output from the DSP is clipped and scaled to a 12-bit data word which spans the acceleration range of the device. [Figure 22](#) shows the method used to establish the output acceleration data word from the DSP output.

Over Range				Signal												Noise			
D19	D18	D17	D16	D15	D14	D13	D12	D11	D10	D9	D8	D7	D6	D5	D4	D3	D2	D1	D0
12-Bit Data Word				D15	D14	D13	D12	D11	D10	D9	D8	D7	D6	D5	D4	Using Rounding			

Figure 22. 12-Bit Output Scaling Diagram

3.8.8 Data Interpolation

The device includes 2 to 1 data interpolation to minimize the system sample jitter. Each result produced by the digital signal processing chain is delayed one half of a sample time, and the interpolated value of successive samples is provided between sample times. This operation is illustrated below.

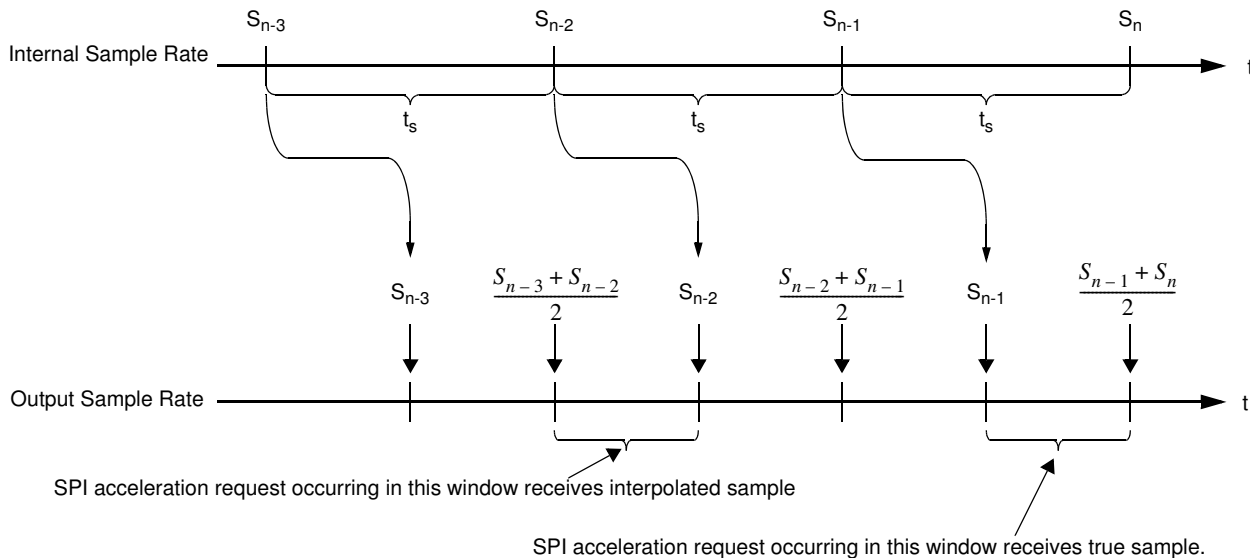

Figure 23. Data Interpolation Timing

The effect of this interpolation at the system level is a 50% reduction in sample jitter. Figure 24 shows the resulting output data for an input signal.

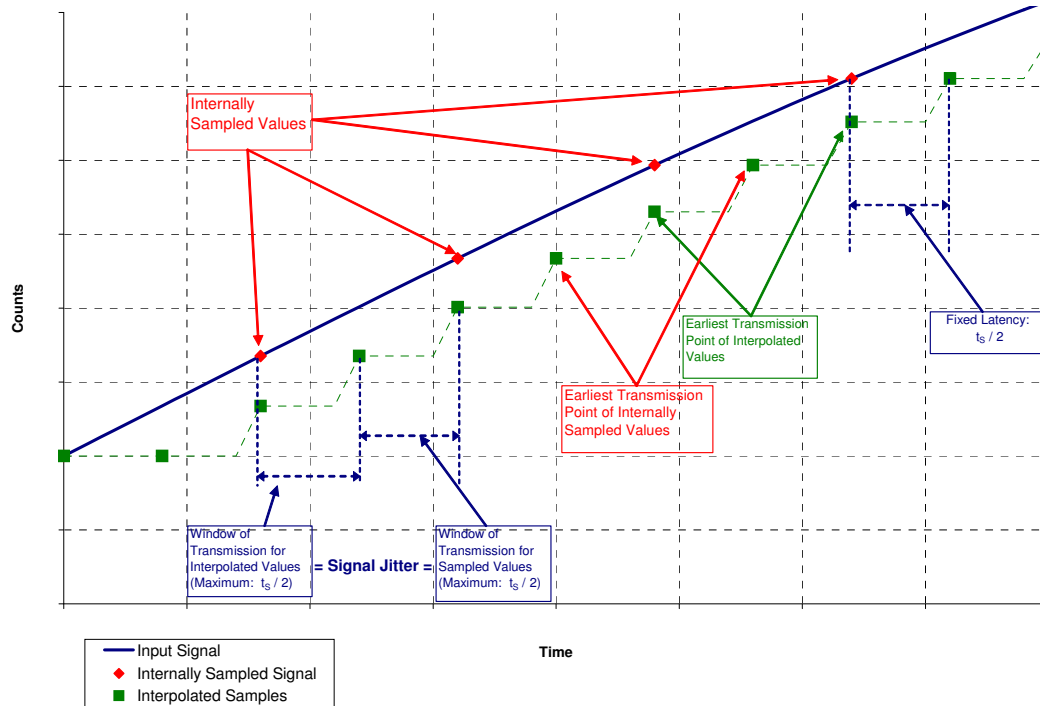

Figure 24. Data Interpolation Example

3.8.9 Acceleration Data Timing

The SPI uses a request/response protocol, where a SPI transfer is completed through a sequence of 2 phases. Reference Section 4 for more details regarding the SPI protocol. The device latches the associated data for an acceleration request at the rising edge of \overline{CS} . The most recent sample available from the DSP (including interpolation) is latched, and transmitted during the subsequent SPI transfer.

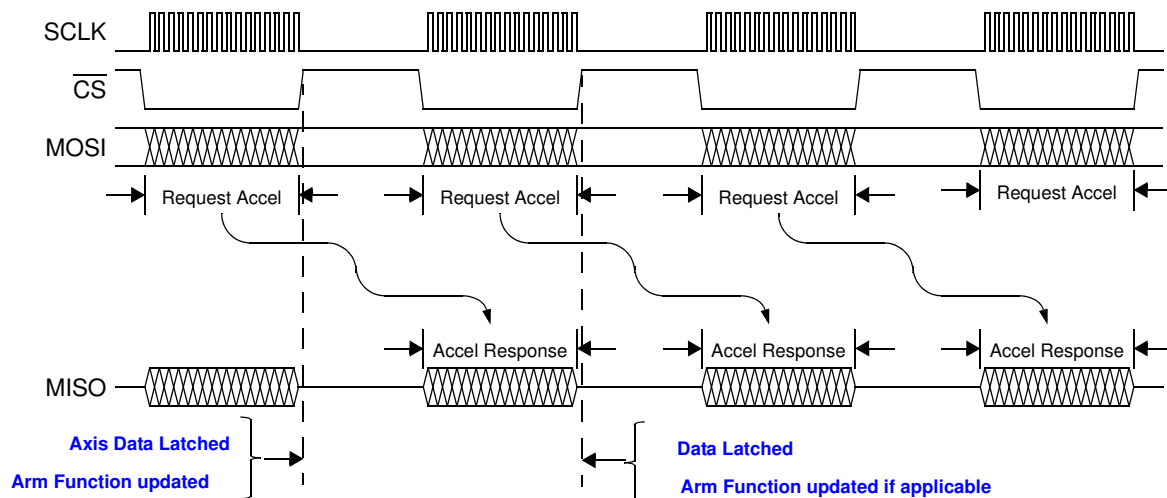

Figure 25. Acceleration Data Timing

3.8.10 Arming Function

The device provides the option for an arming function with 3 modes of operation. The operation of the arming function is selected by the state of the A_CFG bits in the DEVCFG register.

Reference [Section 4.5](#) for the operation of the Arming function with exception conditions. Error conditions do not impact prior arming function responses. If an error occurs after an arming activation, the corresponding pulse stretch for the existing arming condition will continue. However, new acceleration reads will not update the arming function regardless of the acceleration value.

3.8.10.1 Arming Function: Moving Average Mode

In moving average mode, the arming function runs a moving average on the offset cancelled output. The number of samples used for the moving average (k) is programmable via the AWS_x[1:0] bits in the ARMCFGX register. Reference [Section 3.1.8](#) for register details.

$$ARM_MA_n = (OC_n + OC_{n-1} + \dots + OC_{n+1-k})/k$$

Where n is the current sample.

The sample rate is determined by the SPI acceleration data sample rate. At the rising edge of \overline{CS} for an acceleration data SPI request, the moving average is updated with a new sample. Reference [Figure 28](#). The SPI acceleration data sample rate must meet the minimum time between requests ($t_{ACC_REQ_x}$) specified in [Section 2.5](#).

The moving average output is compared against positive and negative 8-bit thresholds that are programmed via the ARMT_x registers. Reference [Section 3.1.10](#) for register details. If the moving average equals or exceeds either threshold, an arming condition is indicated, the ARM output is asserted for the associated axis, and the pulse stretch counter is set as described in [Section 3.8.10.4](#).

The ARM output is de-asserted only when the pulse stretch counter expires. [Figure 28](#) shows the arming output operation for different SPI conditions.

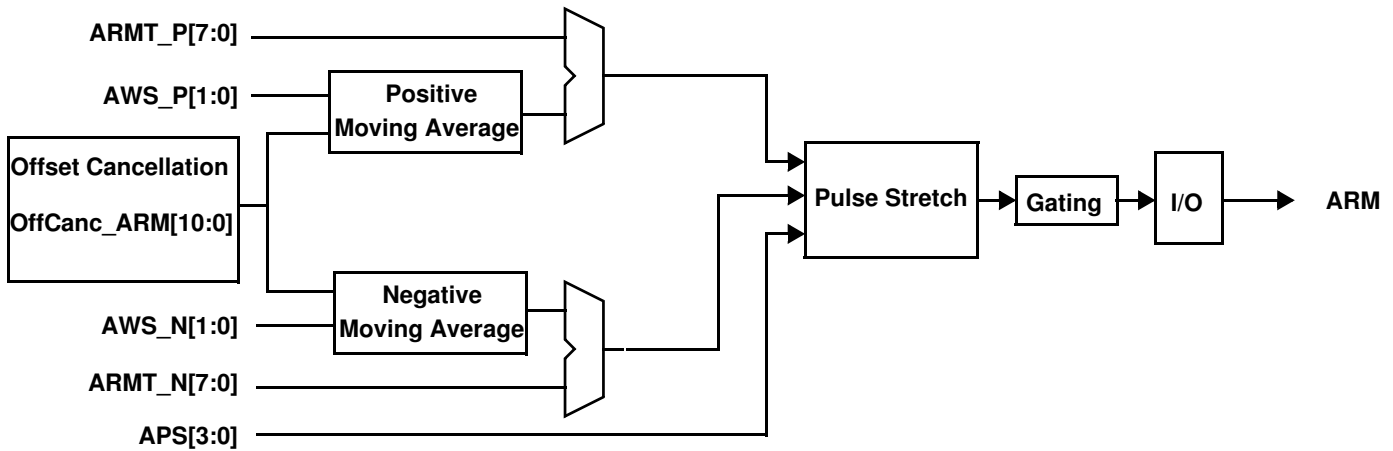

Figure 26. Arming Function Block Diagram - Moving Average Mode

The moving average window size must be set prior to setting the arming function to moving average mode, or prior to requesting acceleration data via the SPI. If the moving average window size is changed after enabling moving average mode, the arming function must first be disabled by setting the A_CFG bits to "000". Once the desired moving average window size is set, the moving average mode can be re-enabled.

3.8.10.2 Arming Function: Count Mode

In count mode, the arming function compares each offset cancelled sample against positive and negative thresholds that are programmed via the ARMT_x registers. Reference [Section 3.1.10](#) for register details. If the sample equals or exceeds either threshold, a sample counter is incremented. If the sample does not exceed either threshold, the sample counter is reset to zero.

The sample rate is determined by the SPI acceleration data sample rate. At the rising edge of \overline{CS} for an acceleration data SPI request, a new sample is compared against the thresholds. Reference [Figure 28](#). The SPI acceleration data sample rate must meet the minimum time between requests ($t_{ACC_REQ_x}$) specified in [Section 2.5](#).

A sample count limit is programmable via the AWS_x[1:0] bits in the ARMCFG register. If the sample count reaches the programmable sample count limit, an arming condition is indicated, the ARM output is asserted for the associated axis, and the pulse stretch counter is set as described in [Section 3.8.10.4](#).

The ARM output is de-asserted only when the pulse stretch counter expires. [Figure 28](#) shows the arming output operation for different SPI conditions.

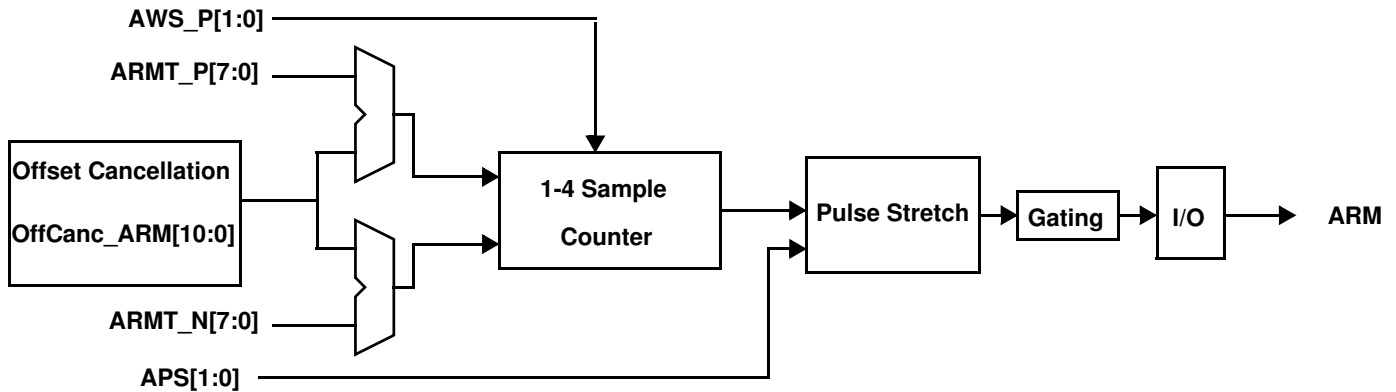

Figure 27. Arming Function Block Diagram - Count Mode

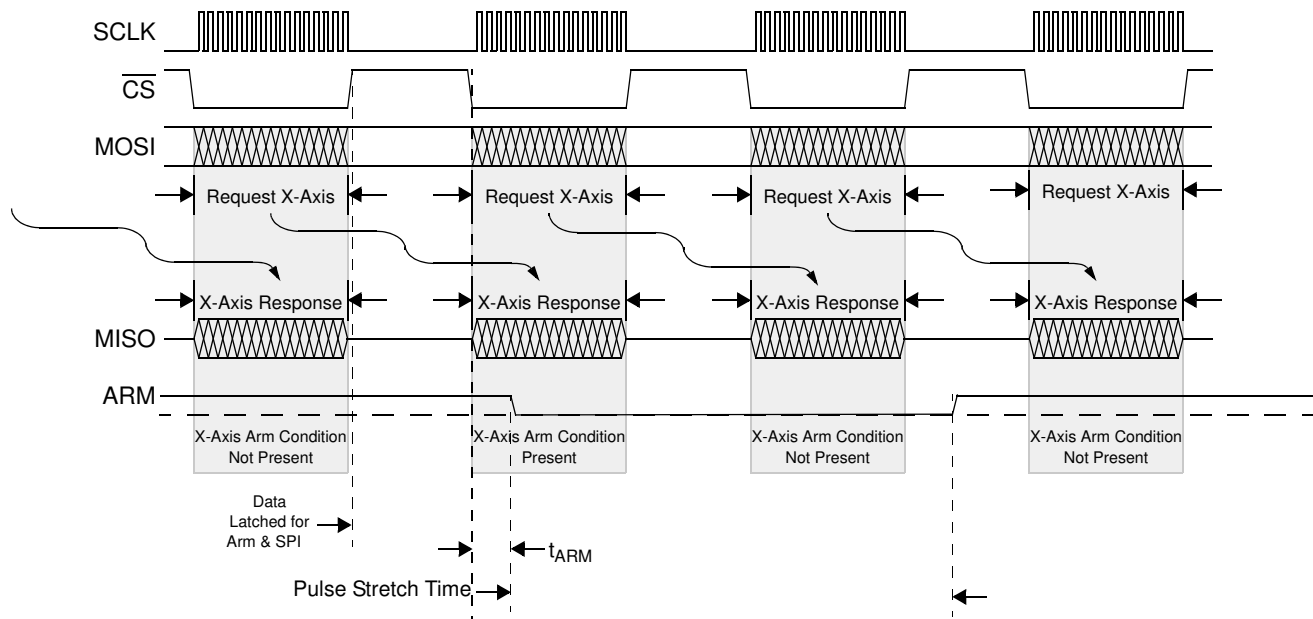

Figure 28. Arming Condition, Moving Average and Count Mode

3.8.10.3 Arming Function: Unfiltered Mode

On the rising edge of \overline{CS} for an acceleration request, the most recent available offset cancelled sample for the requested axis is compared against positive and negative thresholds that are programmed via the $ARMT_x$ registers. Reference [Section 3.1.10](#) for register details. If the sample equals or exceeds either threshold, an arming condition is indicated.

Once an arming condition is indicated for the ARM output is asserted when \overline{CS} is asserted and the MISO data includes an acceleration response for that axis.

The pulse stretch function is not applied in Unfiltered mode.

[Figure 29](#) contains a block diagram of the Arming Function operation in Unfiltered Mode. [Figure 30](#) shows the Arming output operation under the different SPI request conditions.

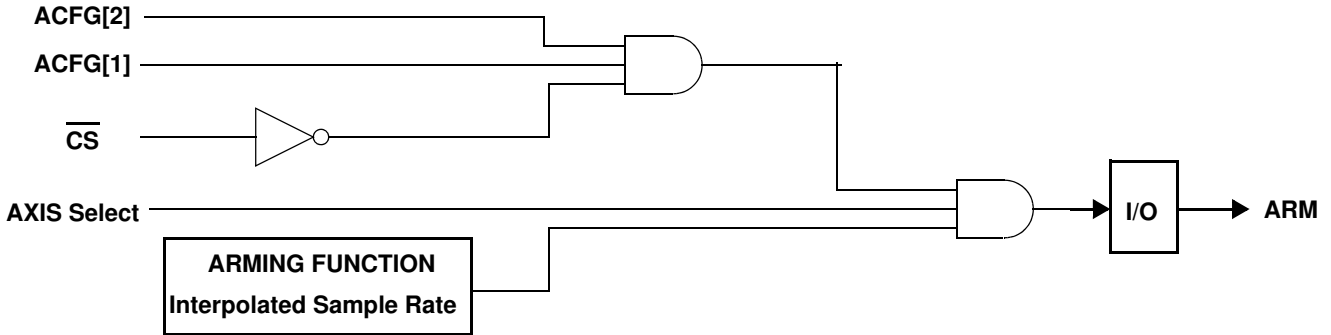

Figure 29. Arming Function Block Diagram - Unfiltered Mode

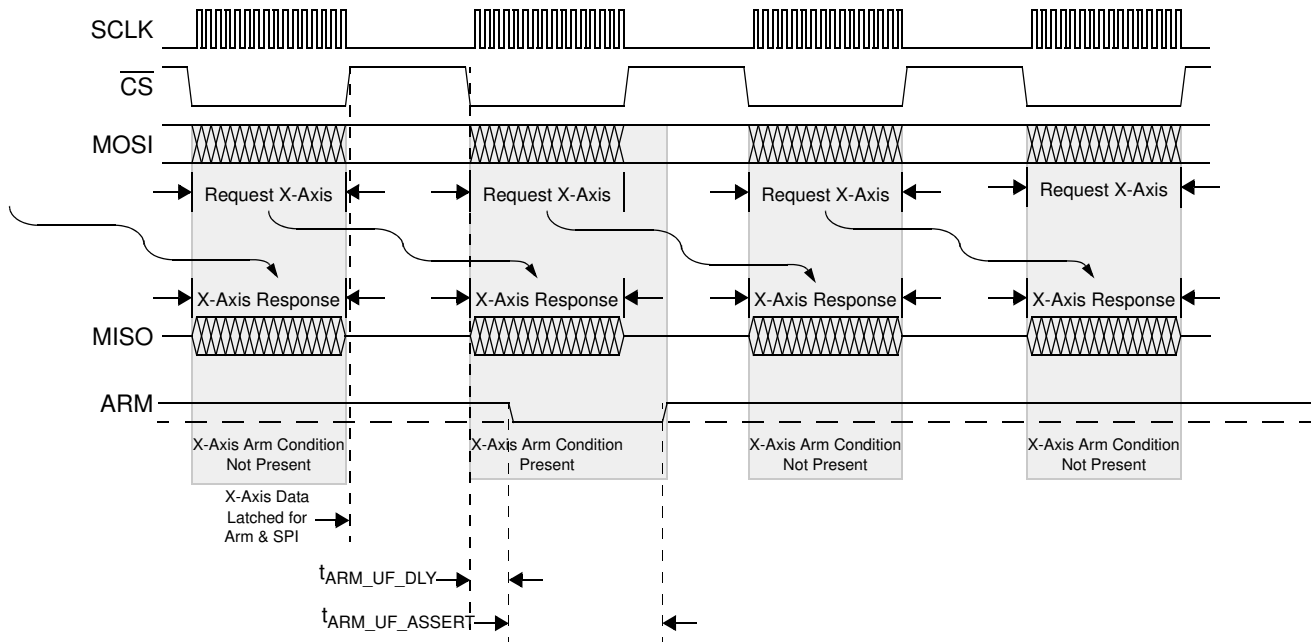

Figure 30. Arming Condition, Unfiltered Mode

3.8.10.4 Arming Pulse Stretch Function

A pulse stretch function can be applied to the arming output in moving average mode, or count mode.

If the pulse stretch function is not used ($APS[1:0] = '00'$), the arming output is asserted if and only if an arming condition exists for the associated axis after the most recent evaluated sample. The arming output is de-asserted if and only if an arming condition does not exist for the associated axis after the most recent evaluated sample.

If the pulse stretch function is used, ($APS[1:0]$ not equal $'00'$), the arming output is controlled only by the value of the pulse stretch timer value. If the pulse stretch timer value is non-zero, the arming output is asserted. If the pulse stretch timer is zero, the arming output is de-asserted. The pulse stretch counter continuously decrements until it reaches zero. The pulse stretch counter is reset to the programmed pulse stretch value if and only if an arming condition exists for the associated axis after the most recent evaluated sample. Reference [Figure 28](#).

The desired pulse stretch time is programmable for via the $APS[1:0]$ bits in the $ARMCFG$ register.

Exception conditions listed in [Section 4.5](#) do not impact prior arming function responses. If an exception occurs after an arming activation, the corresponding pulse stretch for the existing arming condition will continue. However, new acceleration reads will not reset the pulse stretch counter regardless of the acceleration value.

3.8.10.5 Arming Pin Output Structure

The arming output pin structure can be set to active high, or active low with the A_CFG bits in the $DEVCFG$ register as described in [Section 3.1.6.6](#). The active high and active low pin output structures are shown in [Figure 31](#).

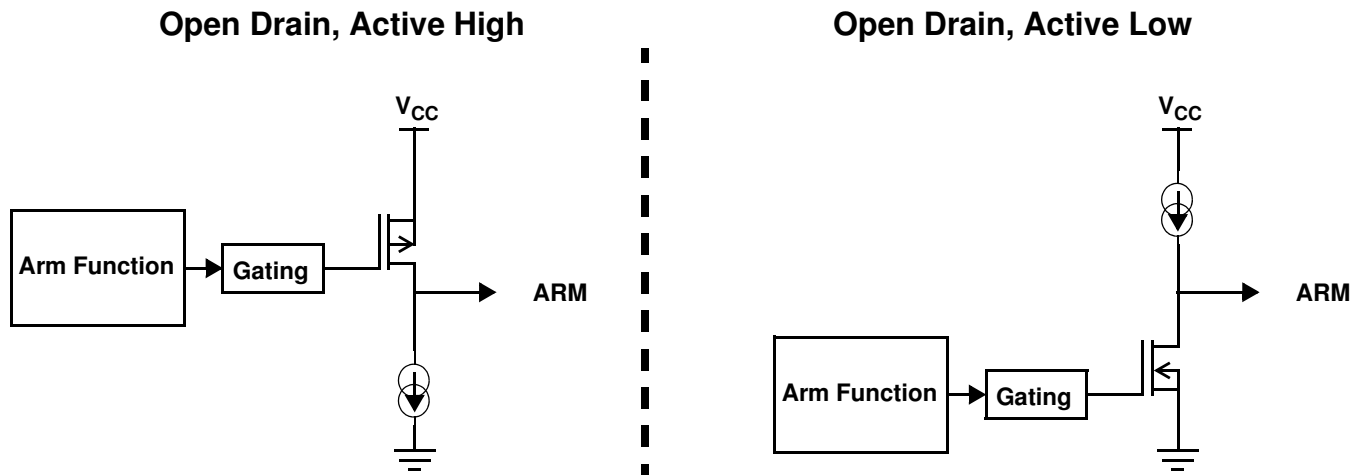

Figure 31. Arming Function - Pin Output Structure

3.8.11 PCM Output Function

The device provides the option for a PCM output function. The PCM output is enabled by setting the A_CFG bits in the DEVCFG register to the appropriate state as described in [Section 3.1.6.6](#). Selecting the PCM output enables the following functions:

- The PCM pin is programmed as a digital output. Reference [Section 2.3](#) for the pin electrical parameters.
- The acceleration value output from the offset cancellation block is saturated to 9-bits and converted to an unsigned value. Note, the 9-bit unsigned acceleration value uses the full range of values (0 - 511).
- The 9-bit acceleration value is input into a summer clocked at 8MHz.
- The carry from the summer circuit is output to the PCM pin.

A block diagram of the PCM output is shown in [Figure 32](#).

Exception conditions affect the PCM output as listed in [Section 4.5](#).

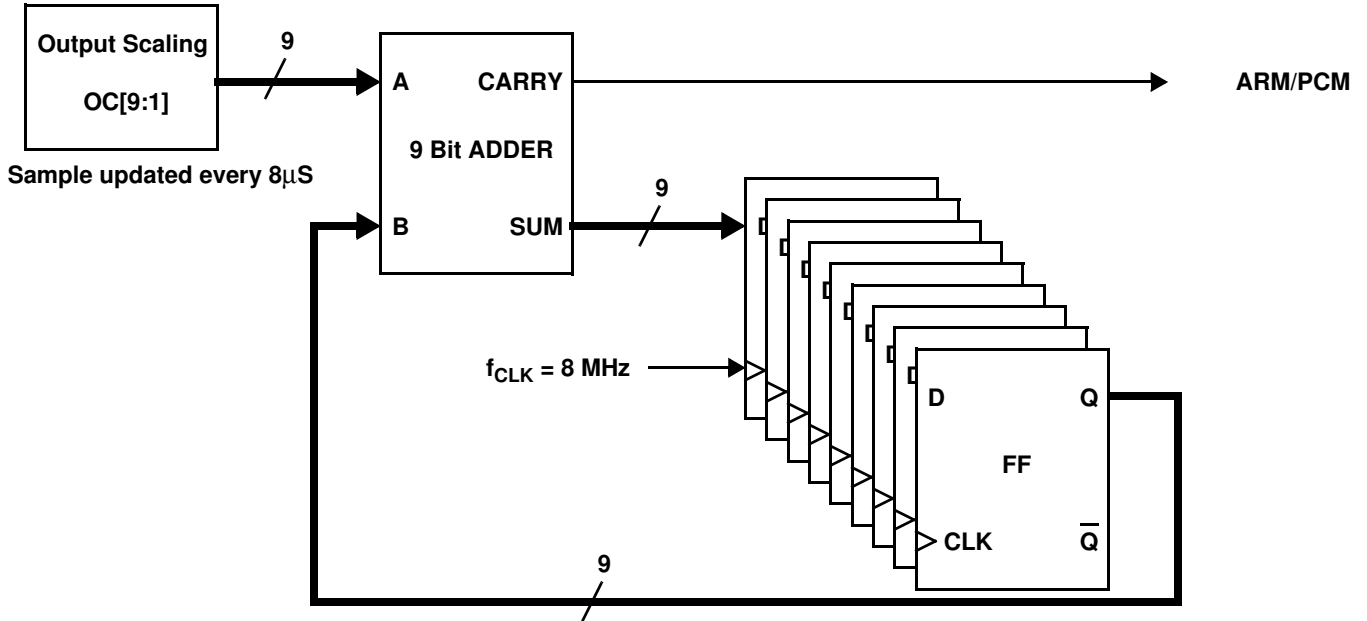

Figure 32. PCM Output Function Block Diagram

3.9 Serial Peripheral Interface

The device includes a Serial Peripheral Interface (SPI) to provide access to the configuration registers and digital data. Reference [Section 4](#) for details regarding the SPI protocol and available commands.

3.10 Device Initialization

Following power-up, under-voltage reset, or a SPI reset command sequence, the device proceeds through an internal initialization process as shown below. Figure 33 also shows the device performance for an example external system level initialization procedure.

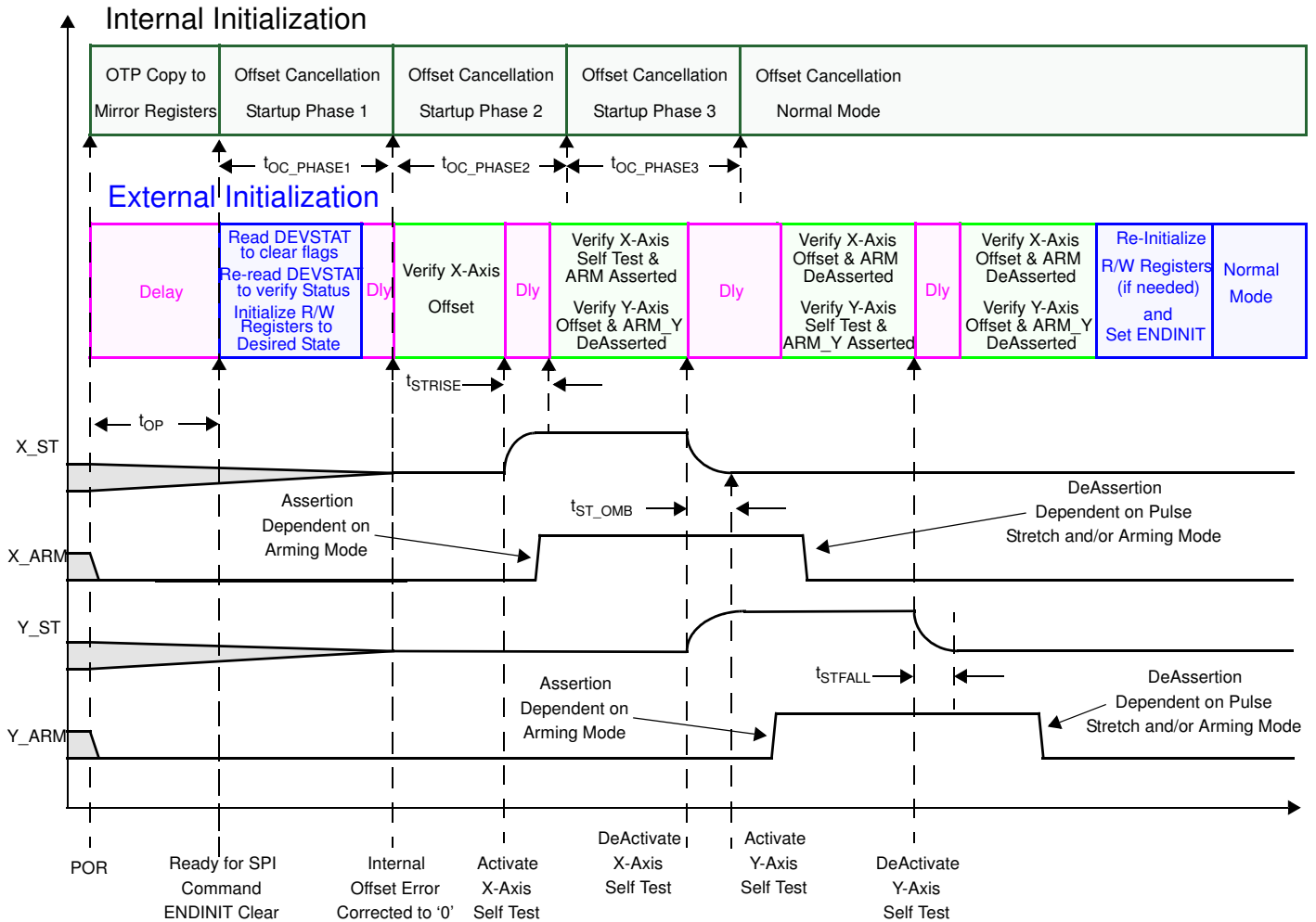

Notes:1) X-Axis and Y-Axis Self Test can be enabled and evaluated simultaneously to reduce test time.
For failure mode coverage of the arming pins and of potential common axis failures, Freescale recommends independent self test activation.
2) t_{STRISE} and t_{STFALL} are dependent on the selected LPF group delay.

Figure 33. Initialization Process

3.11 Overload Response

3.11.1 Overload Performance

The device is designed to operate within a specified range. Acceleration beyond that range (overload) impacts the output of the sensor. Acceleration beyond the range of the device can generate a DC shift at the output of the device that is dependent upon the overload frequency and amplitude. The g-cell is overdamped, providing the optimal design for overload performance. However, the performance of the device during an overload condition is affected by many other parameters, including:

- g-cell damping
- Non-linearity
- Clipping limits
- Symmetry

Figure 34 shows the g-cell, ADC and output clipping of the device over frequency. The relevant parameters are specified in Section 2.1, and Section 2.6.

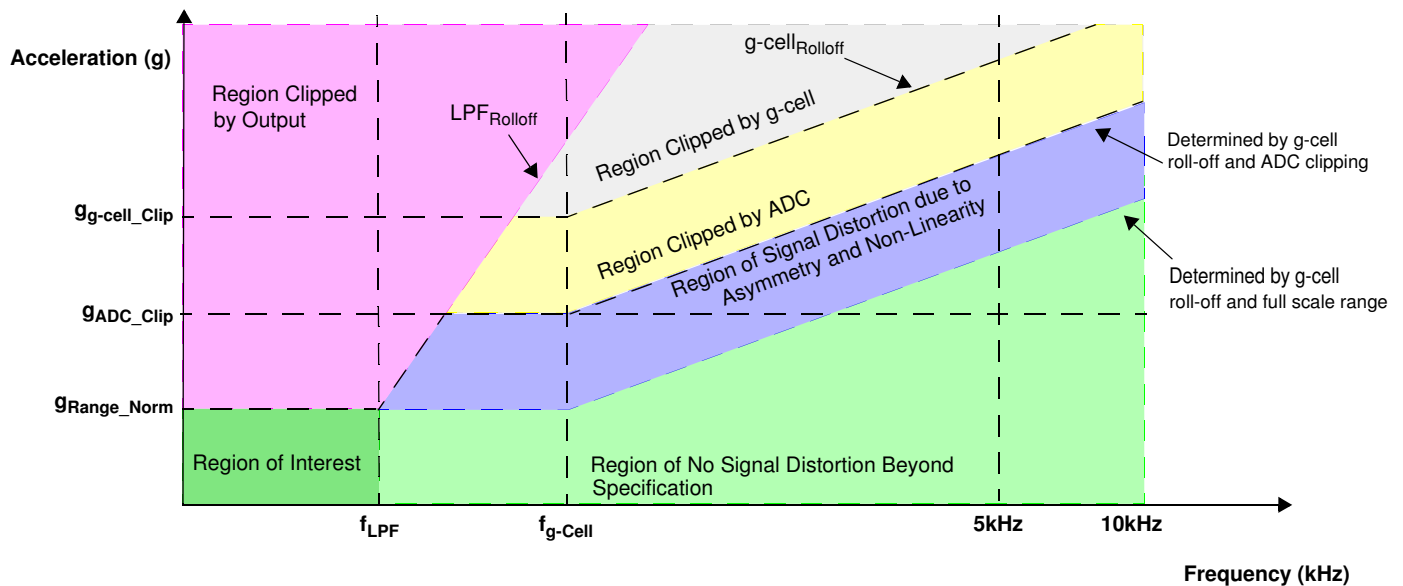

Figure 34. Output Clipping vs. Frequency

3.11.2 Sigma Delta Over Range Response

Over range conditions exist when the signal level is beyond the full-scale range of the device but within the computational limits of the DSP. The $\Sigma\Delta$ converter can saturate at levels above those specified in Section 2.1 ($G_{\text{ADC_CLIP}}$). The DSP operates predictably under all cases of over range, although the signal may include residual high frequency components for some time after returning to the normal range of operation due to non-linear effects of the sensor.

4 SPI Communications

Communication with the device is completed through synchronous serial transfers via SPI. The device is a slave device configured for CPOL = 0, CPHA = 0, MSB first. SPI transfers are completed through a sequence of two phases. During the first phase, the type of transfer and associated control information is transmitted from the SPI master to the device. Data from the device is transmitted during the second phase. Any activity on MOSI or SCLK is ignored when CS is negated. Consequently, intermediate transfers involving other SPI devices may occur between phase one and phase two. Reference [Figure 35](#).

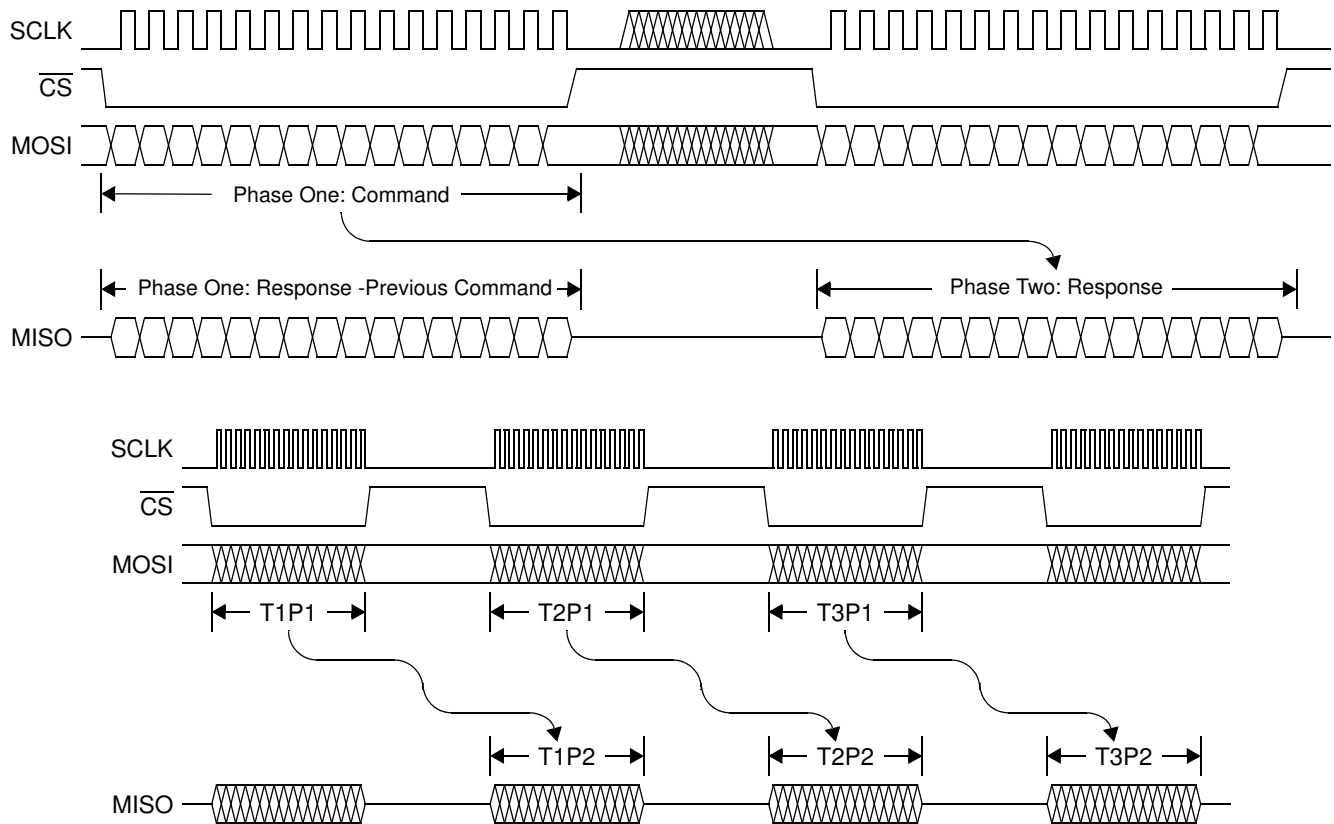

Figure 35. SPI Transfer Detail

4.1 SPI Command Format

Commands are transferred from the SPI master to the device. Valid commands fall into two categories: register operations, and acceleration data requests.

Table 26. SPI Command Message Summary

MSB													LSB					
15	14	13	12	11	10	9	8	7	6	5	4	3	2	1	0	Command Type	Reference	
0	AX	A	OC	0	0	0	0	0	0	0	0	1	SD	ARM	P			
AX= Axis Selection																		
0				Acceleration Data														
1				N/A														
A = Acceleration Data Request																		
0				Register Operation														
1				Acceleration Data Request														
OC = Offset Cancelled Data Confirmation																		
0				Offset Cancelled Data Enabled														
1				Raw Acceleration Data Enabled														
SD = Signed Data Confirmation																		
				Signed Data Enabled										0				
				Unsigned Data Enabled										1				
ARM = ARM Function Status Confirmation																		
				Disabled / PCM Output Enabled										0				
				Arming Function Enabled										1				
															P = Odd Parity			
0	AX	A	OC	0	0	0	0	0	0	0	0	0	SD	ARM	P	Accel Data		
0	0	1	0	0	0	0	0	0	0	0	0	0	1	0	0	1	OC, Signed Data, Disabled/PCM	
0	0	1	0	0	0	0	0	0	0	0	0	0	1	0	1	0	OC, Signed Data, ARM Enabled	
0	0	1	0	0	0	0	0	0	0	0	0	0	1	1	0	0	OC, Unsigned Data, Disabled/PCM	
0	0	1	0	0	0	0	0	0	0	0	0	0	1	1	1	1	OC, Unsigned Data, ARM Enabled	
0	0	1	1	0	0	0	0	0	0	0	0	0	1	0	0	0	Raw, Signed Data, Disabled/PCM	
0	0	1	1	0	0	0	0	0	0	0	0	0	1	0	1	1	Raw, Signed Data, ARM Enabled	
0	0	1	1	0	0	0	0	0	0	0	0	0	1	1	0	1	Raw, Unsigned Data, Disabled/PCM	
0	0	1	1	0	0	0	0	0	0	0	0	0	1	1	1	0	Raw, Unsigned Data, ARM Enabled	
0	1	1	0	0	0	0	0	0	0	0	0	0	1	0	0	0	Invalid Command	
0	1	1	0	0	0	0	0	0	0	0	0	0	1	0	1	1	Invalid Command	
0	1	1	0	0	0	0	0	0	0	0	0	0	1	1	0	1	Invalid Command	
0	1	1	0	0	0	0	0	0	0	0	0	0	1	1	1	0	Invalid Command	
0	1	1	1	0	0	0	0	0	0	0	0	0	1	0	0	1	Invalid Command	
0	1	1	1	0	0	0	0	0	0	0	0	0	1	0	1	0	Invalid Command	
0	1	1	1	0	0	0	0	0	0	0	0	0	1	1	0	0	Invalid Command	
0	1	1	1	0	0	0	0	0	0	0	0	0	1	1	1	1	Invalid Command	
P	AX	A	D12	D11	D10	D9	D8	D7	D6	D5	D4	D3	D2	D1	D0	Command Type	Reference	
P	0	0	A4	A3	A2	A1	A0	0	0	0	0	0	0	0	0	Register Read	Section 4.4	
			Register Address															
P	1	0	A4	A3	A2	A1	A0	D7	D6	D5	D4	D3	D2	D1	D0	Register Write	Section 4.4	
			Register Address					Data to be Written to Register										
P = Odd Parity																		

4.2 SPI Response Format

Table 27. SPI Response Message Summary

			MSB													LSB				
			15	14	13	12	11	10	9	8	7	6	5	4	3	2	1	0		
CMD	A	AX	Response to Valid Acceleration Request														Reference			
			D15	D14	AX	P	D11	D10	D9	D8	D7	D6	D5	D4	D3	D2		D1	D0	
			D1	D0	Acceleration Data			D11	D10	D9	D8	D7	D6	D5	D4	D3	D2			
			AX = Axis Requested																	
			0	Acceleration Data Response																
			1	N/A																
			P = Odd Parity																	
			S[1:0] = Device Status																	
			0	0	In Initialization (ENDINIT = '0')															
			0	1	Normal Data Request															
			1	0	ST Active															
			1	1	Internal Error Present / SPI Error															
CMD	A	AX	D1	D0	AX	P	S1	S0	D11	D10	D9	D8	D7	D6	D5	D4	D3	D2	Reference	
Valid Accel Data Request	1	0	Accel Data	0	P	0	1	Acceleration Data											Section 4.3	
	1	0	Accel Data	0	P	1	0	Self Test Active Acceleration Data												
	1	0	Accel Data	0	P	0	0	Acceleration Data, Initialization in Process (ENDINIT='0')												
	1	1	Accel Data	1	P	0	1	Invalid Accel Request												
	1	1	Accel Data	1	P	1	0	Invalid Accel Request												
	1	1	Accel Data	1	P	0	0	Invalid Accel Request												
			MSB													LSB				
			15	14	13	12	11	10	9	8	7	6	5	4	3	2	1	0		
CMD	A	AX	Response to Valid Register Access														Reference			
			D15	D14	AX	P	D11	D10	D9	D8	D7	D6	D5	D4	D3	D2		D1	D0	
Register Write	0	1	0	0	1	P	1	1	1	0	D7	D6	D5	D4	D3	D2	D1	D0	Section 4.4.1	
											New Contents of Register									
Register Read	0	0	0	1	0	P	1	1	1	0	D7	D6	D5	D4	D3	D2	D1	D0	Section 4.4.2	
											Contents of Register									
			MSB													LSB				
			15	14	13	12	11	10	9	8	7	6	5	4	3	2	1	0		
CMD	A	AX	Error Responses														Reference			
			D15	D14	AX	P	D11	D10	D9	D8	D7	D6	D5	D4	D3	D2		D1	D0	
Invalid Accel Request	x	x	0	0	AX	P	1	1	0	0	0	0	0	0	0	0	0	Section 4.3		
Internal Error Present	x	x	0	0	0	P	1	1	0	0	0	0	0	0	0	0	0	Section 4.5.5		
MISO Error	x	x	0	0	0	P	1	1	0	0	0	0	0	0	0	0	0	Section 4.5.2		
SPI Error	x	x	0	0	0	0	1	1	1	0	0	0	0	0	0	0	0	Section 4.5.1		
Invalid Register Request	0	x	0	0	0	0	1	1	1	0	0	0	0	0	0	0	0	Section 4.4		
Self Test Error	0	x	0	0	AX	P	1	1	0	0	0	0	0	0	0	0	0	Section 4.5.5		

4.3 Acceleration Data Transfers

12-Bit Acceleration data requests are initiated when the Acceleration bit of the SPI command message (A) is set to a logic '1', and bit D[3] of the SPI command message is set to a logic '1'. The Axis Selection bit (AX) selects the type of acceleration data requested, as shown in [Table 28](#).

Table 28. Acceleration Data Request

Axis Selection Bit (AX)	Data Type
0	Acceleration Data
1	Invalid Accel Request

To verify that the device is configured as expected, each acceleration data request includes the configuration information which impacts the output data. The requested configuration is compared against the data programmed in the writable register block. Details are shown in [Table 29](#).

Table 29. Acceleration Data Request Configuration Information

Programmable Option	Command Message Bit	Writable Register Information
Raw or Offset Cancelled Data	OC	DEVCFG[7] (\overline{OC})
Signed or Unsigned Data	SD	DEVCFG[4] (\overline{SD})
Arming Function or PCM Output	ARM	DEVCFG[2] DEVCFG[1] (A_CFG[2] A_CFG[1])

If the data listed in [Table 29](#) does not match, an Acceleration Data Request Mismatch failure is detected and no acceleration data is transmitted. Reference [Section 4.5.3.1](#).

Acceleration data request commands include a parity bit (P). Odd parity is employed. The number of logic '1' bits in the acceleration data request command must be an odd number.

Acceleration data is transmitted on the next SPI message if and only if all of the following conditions are met:

- The DEVINIT bit in the DEVSTAT register is not set
- The DEVRES bit in the DEVSTAT register is not set
- The IDE bit in the DEVSTAT register is not set (Reference [Section 4.5.5](#))
- No SPI Error is detected (Reference [Section 4.5.1](#))
- No MISO Error is detected (Reference [Section 4.5.2](#))
- No Acceleration Data Request Mismatch failure is detected (Reference [Section 4.5.3.1](#))
- No Self Test Error is present (reference [Section 4.5.5.2](#))
- No Offset Monitor Error is present for the requested channel (reference [Section 4.5.6](#))

If the above conditions are met, the device responds with a "valid acceleration data request" response as shown in [Table 27](#). Otherwise, the device responds as specified in [Section 4.5](#).

4.4 Register Access Operations

Two types of register access operations are supported; register write, and register read. Register access operations are initiated when the acceleration bit (A) of the command message is set to a logic '0'. The operation to be performed is indicated by the Access Selection bit (AX) of the command message.

Access Selection Bit (AX)	Operation
0	Register Read
1	Register Write

Register Access operations include a parity bit (P). Odd parity is employed. The number of logic '1' bits in the Register Access operation must be an odd number.

4.4.1 Register Write Request

During a register write request, bits 12 through 8 contain a five-bit address, and bits 7 through 0 contain the data value to be written. Writable registers are defined in [Table 3](#).

The response to a register write operation is shown in [Table 27](#). The response is transmitted on the next SPI message if and only if all of the following conditions are met:

- No SPI Error is detected (Reference [Section 4.5.1](#))
- No MISO Error is detected (Reference [Section 4.5.2](#))
- The ENDINIT bit is cleared (Reference [Section 3.1.6.3](#))
- This applies to all registers with the exception of the DEVCTL register (Only Bits 6 and 7 can be modified)
- No Invalid Register Request is detected (Reference [Section 4.5.3.2](#))

If the above conditions are met, the device responds to the register write request as shown in [Table 27](#). Otherwise, the device Responds as specified in [Section 4.5](#).

Register write operations do not occur internally until the transfer during which they are requested has been completed. In the event that a SPI Error is detected during a register write transfer, the write operation is not completed.

4.4.2 Register Read Request

During a register read request, bits 12 through 8 contain the five-bit address for the register to be read. Bits 7 through 0 must be logic '0'. Readable registers are defined in [Table 3](#).

The response to a register read operation is shown in [Table 27](#). The response is transmitted on the next SPI message if and only if all of the following conditions are met:

- No SPI Error is detected (Reference [Section 4.5.1](#))
- No MISO Error is detected (Reference [Section 4.5.2](#))
- No Invalid Register Request is detected (Reference [Section 4.5.3.2](#))

If the above conditions are met, the device responds to the register read request as shown in [Table 27](#). Otherwise, the device responds as specified in [Section 4.5](#).

4.5 Exception Handling

The following sections describe the conditions and the device response for each detectable exception. In the event that multiple exceptions exist, the exception response is determined by the priority listed in [Table 30](#).

Table 30. SPI Error Response Priority

Error Priority	Exception	Effect on Data		
		SPI Data	Arming Output	PCM Output
1	SPI Error	Error Response	No Update	No Effect
2	SPI MISO Error	Error Response	No Update	No Effect
3	Invalid Request	Error Response	No Update	No Effect
4	DEVINIT Bit Set	Error Response	No Update	Disabled
5	DEVRES Error	Error Response	No Update	Disabled
6	CRC Error	Error Response	No Update	No Effect
7	Self Test Error	Error Response	No Update	No Effect
8	Offset Monitor Error	Error Response	No Update	No Effect

4.5.1 SPI Error

The following SPI conditions result in a SPI error:

- SCLK is high when \overline{CS} is asserted
- The number of SCLK rising edges detected while \overline{CS} is asserted is not equal to 16
- SCLK is high when \overline{CS} is negated
- Command message parity error (MOSI)
- Bit 15 of Acceleration Data Request is not equal to '0'
- Bits 4 through 11 of an Acceleration Request are not equal to '0'
- Bits 3 of an Acceleration Request is not equal to '1'
- Bits 0 through 7 of a Register Read Request are not equal to '0'

The device responds to a SPI error with a "SPI Error" response as shown in Table 30. This applies to both acceleration data request SPI errors, and Register Access SPI errors.

The arming function will not be updated if a SPI Error is detected. The PCM output is not affected by a SPI Error.

4.5.2 SPI Data Output Verification Error

The device includes a function to verify the integrity of the data output to the MISO pin. The function reads the data transmitted on the MISO pin and compares it against the data intended to be transmitted. If any one bit doesn't match, a SPI MISO Mismatch Fault is detected and the MISOERR flag in the DEVSTAT register is set.

If a valid SPI acceleration request message is received during the SPI transfer with the MISO mismatch failure, the SPI acceleration request message is ignored and the device responds with a "MISO Error" response during the subsequent SPI message (reference Table 30). The Arming function is not updated if a MISO mismatch failure occurs. The PCM function is not affected by the MISO mismatch failure.

If a valid SPI register write request message is received during the SPI transfer with the MISO mismatch failure, the register write is completed as requested, but the device responds with a "MISO Error" response as shown in Table 30, during the subsequent SPI message.

If a valid SPI register read request message is received during the SPI transfer with the MISO mismatch failure, the register read is ignored and the device responds with a "MISO Error" response as shown in Table 30, during the subsequent SPI message. If the register read request is for the DEVSTAT register, the DEVSTAT register will not be cleared.

In all cases, the MISOERR flag in the DEVSTAT register will remain set until a successful SPI Register Read Request of the DEVSTAT register is completed.

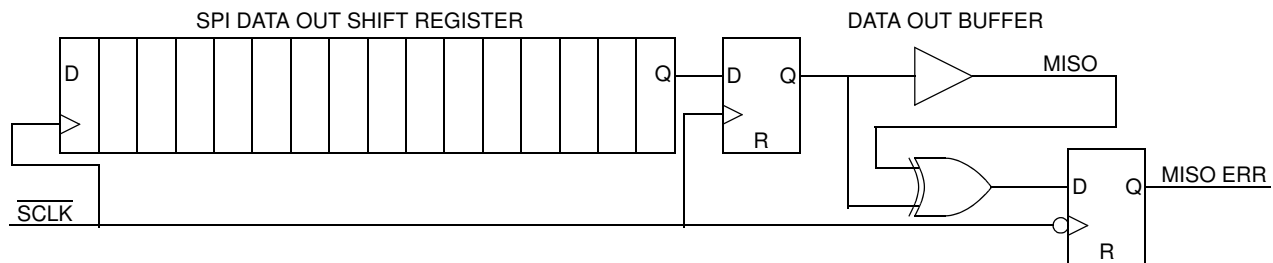

Figure 36. SPI Data Output Verification

4.5.3 Invalid Requests

4.5.3.1 Invalid Acceleration Request

The following conditions result in an "Invalid Acceleration Request" error:

- The Axis Selection bit (AX) in the Command message is set
- The SPI "Acceleration Data Request" Command data listed in Section 4.3, Table 28 does not match the internal register settings

The device responds to an "Invalid Acceleration Request" error with an "Invalid Accel Request" response as specified in Table 30 on the subsequent SPI message only. No internal fault is recorded. The arming function will not be updated if an "Acceleration Data Request Mismatch" Error is detected. The PCM output is not affected by the "Acceleration Data Request Mismatch" error.

Register operations will be executed as specified in Section 4.4.

4.5.3.2 Invalid Register Request

The following conditions result in an “Invalid Register Request” error:

- An attempt is made to write to an un-writable register (Writable registers are defined in [Section 3.1](#), [Table 3](#)). Attempts to write to registers \$07, \$09, \$0D, \$0F, \$11, & \$13, \$18, \$19, \$1A and \$1B will result in an error.
- An attempt is made to write to a register while the ENDINIT bit in the DEVCFG register is set
- This applies to all registers with the exception of the DEVCTL register (Only Bits 6 and 7 can be modified)
- An attempt is made to read an un-readable register (Readable registers are defined in [Section 3.1](#), [Table 3](#)). Attempts to read registers \$07, \$09, \$0D, \$0F, \$11, & \$13, \$18, \$19, \$1A and \$1B will result in an error.

The device responds to an “Invalid Register Request” error with an “Invalid Register Request” response as shown in [Table 30](#).

4.5.4 Device Reset Indications

If the DEVINIT, or DEVRES bit is set in the DEVSTAT register as described in [Section 3.1.11](#), the device will respond to acceleration data requests with an “Internal Error Present” response until the bits are cleared in the DEVSTAT register. The DEVINIT bit is cleared automatically when device initialization is complete (Reference t_{OP} in [Section 2.6](#)). The DEVRES bit is cleared on a read of the DEVSTAT register. The arming function will not be updated on Acceleration Data Request commands if the DEVINIT or DEVRES bit is set in the DEVSTAT register. The PCM output is disabled if the DEVINIT or DEVRES bit is set.

4.5.5 Internal Error

The following errors will result in an internal error, and set the IDE bit in the DEVSTAT register:

- OTP CRC Failure
- Writable Register CRC Failure
- Self Test Error
- Invalid internal logic states

4.5.5.1 CRC Error

If the IDE bit is set in the DEVSTAT register due to one or more of the following errors, the device will respond to acceleration data requests with an “Internal Error Present” response until the IDE bit is cleared in the DEVSTAT register.

- An OTP Shadow Register CRC failure as described in [Section 3.2](#)
- A Writable Register CRC failure as described in [Section 3.2](#)

The arming function will not be updated on Acceleration Data Request commands if a CRC Error is detected. The PCM output is not affected by the CRC error.

If the CRC error is in the writable register array, and the ENDINIT bit in the DEVCFG register has been set, the error can only be cleared by a device reset. The IDE bit will not be cleared on a read of the DEVSTAT register.

If the CRC error is in the OTP shadow register array, the error cannot be cleared.

Register operations will be executed as specified in [Section 4.4](#).

4.5.5.2 Self Test Error

If the IDE bit is set in the DEVSTAT register due to a Self Test activation failure, the device will respond to acceleration data requests with a “Self Test Error” response until the IDE bit is cleared in the DEVSTAT register. The arming function will not be updated on Acceleration Data Request commands if a Self Test Error is detected. The PCM output is not affected by the Self Test Error. The IDE bit in the DEVSTAT register will remain set until a read of the DEVSTAT register occurs, even if the internal failure is removed. If the internal error is still present when the DEVSTAT register is read, the IDE bit will remain set.

Register operations will be executed as specified in [Section 4.4](#).

4.5.6 Offset Monitor Error

If an offset monitor error is present as described in [Section 3.8.5](#), the OFFSET bit in the DEVSTAT register will be set. The device will respond to an acceleration request with an “Internal Error Present” response until the OFFSET bit is cleared in the DEVSTAT register. The arming function will not be updated. Once the error condition is removed, the OFFSET bit in the DEVSTAT register will remain set until a read of the DEVSTAT register occurs.

The PCM output is not affected by the offset monitor over range condition.

Register operations will be executed as specified in [Section 4.4](#).

4.6 Initialization SPI Response

The first data transmitted by the device following reset is the SPI Error response shown in [Table 30](#). This ensures that an unexpected reset will always be detectable. The device will respond to all acceleration data requests with the “Invalid Acceleration Data Request” response until the DEVRES bit in the DEVSTAT register is cleared via a read of the DEVSTAT register. The arming function will not be updated on Acceleration Data Request commands until the DEVRES bit in the DEVSTAT register is cleared.

4.7 Acceleration Data Representation

Acceleration values are determined from the 12-bit digital output (DV) using the following equations:

$$\text{Acceleration} = \text{Sensitivity}_{LSB} \times DV \quad \text{For Signed Data}$$

$$\text{Acceleration} = \text{Sensitivity}_{LSB} \times (DV - 2048) \quad \text{For Unsigned Data}$$

The linear range of digital values for signed data is -1920 to +1920, and for unsigned data is 128 to 3968. Resulting ranges and some nominal acceleration values are shown in the following table.

Table 31. Nominal Acceleration Data Values

Unsigned Digital Value	Signed Digital Value	Nominal Acceleration			
		105g		120g	
3969 - 4095	1921 - 2047	Unused		Unused	
3968	1920	105.49	g	120.00	g
3967	1919	105.44	g	119.94	g
•	•	•	•	•	•
•	•	•	•	•	•
•	•	•	•	•	•
2050	2	0.1099	g	0.1250	g
2049	1	0.0545	g	0.0625	g
2048	0	0	g	0	g
2047	-1	-0.0545	g	-0.0625	g
2046	-2	-0.1099	g	-0.1250	g
•	•	•	•	•	•
•	•	•	•	•	•
•	•	•	•	•	•
129	-1919	-105.44	g	-119.94	g
128	-1920	-105.49	g	-120.00	g
1 - 127	-1921 - 2048	Unused		Unused	
0	0	Fault		Fault	

Figure 37 shows how the possible output data codes are determined from the input data and the error sources. The relevant parameters are specified in Section 2.4.

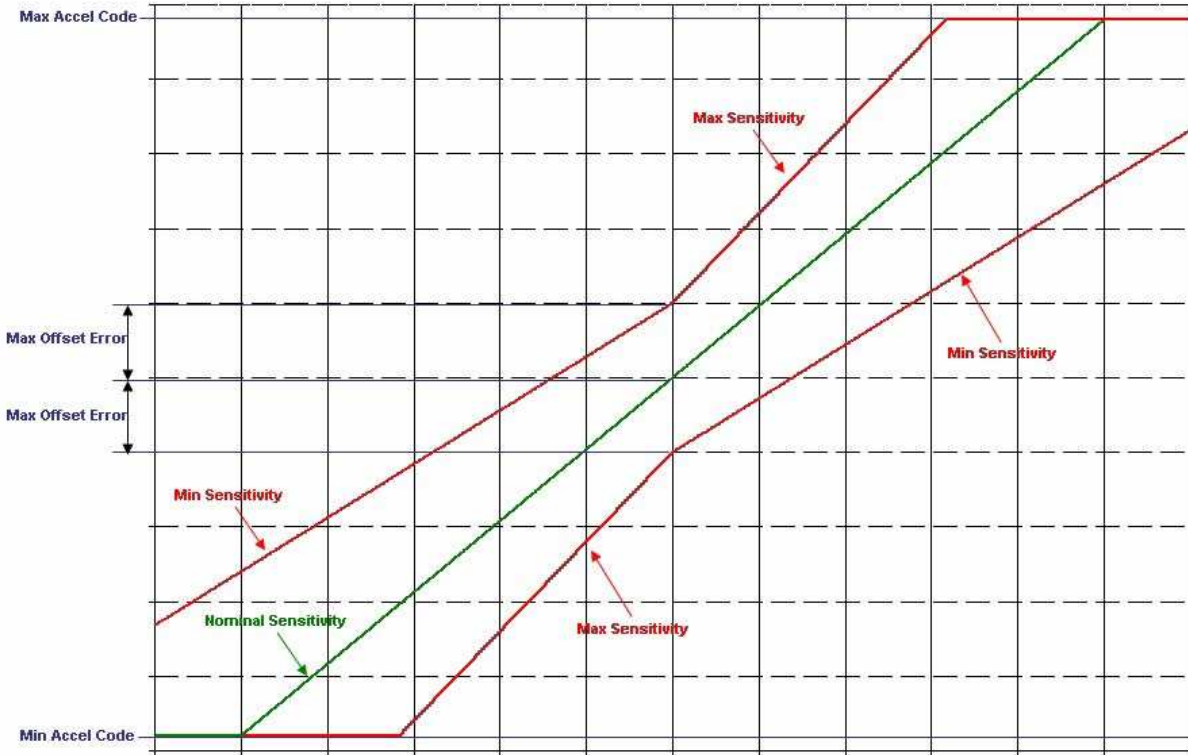

Figure 37. Acceleration Data Output Vs. Acceleration Input

5 Package

5.1 Case Outline Drawing

Reference Freescale Case Outline Drawing # 98ASA00090D

http://www.freescale.com/files/shared/doc/package_info/98ASA00090D.pdf

5.2 Recommended Footprint

Reference Freescale Application Note AN3111, latest revision:

http://www.freescale.com/files/sensors/doc/app_note/AN3111.pdf

Table 1. Revision History

Revision number	Revision date	Description of changes
3	03/2012	<ul style="list-style-type: none">• Added SafeAssure logo, changed first paragraph and disclaimer to include trademark information.• Added devices to ordering table: MMA6555KW and MMA6556KW

How to Reach Us:

Home Page:

www.freescale.com

Web Support:

<http://www.freescale.com/support>

USA/Europe or Locations Not Listed:

Freescale Semiconductor, Inc.
Technical Information Center, EL516
2100 East Elliot Road
Tempe, Arizona 85284
1-800-521-6274 or +1-480-768-2130
www.freescale.com/support

Europe, Middle East, and Africa:

Freescale Halbleiter Deutschland GmbH
Technical Information Center
Schatzbogen 7
81829 Muenchen, Germany
+44 1296 380 456 (English)
+46 8 52200080 (English)
+49 89 92103 559 (German)
+33 1 69 35 48 48 (French)
www.freescale.com/support

Japan:

Freescale Semiconductor Japan Ltd.
Headquarters
ARCO Tower 15F
1-8-1, Shimo-Meguro, Meguro-ku,
Tokyo 153-0064
Japan
0120 191014 or +81 3 5437 9125
support.japan@freescale.com

Asia/Pacific:

Freescale Semiconductor China Ltd.
Exchange Building 23F
No. 118 Jianguo Road
Chaoyang District
Beijing 100022
China
+86 10 5879 8000
support.asia@freescale.com

For Literature Requests Only:

Freescale Semiconductor Literature Distribution Center
1-800-441-2447 or +1-303-675-2140
Fax: +1-303-675-2150
LDCForFreescaleSemiconductor@hibbertgroup.com

Information in this document is provided solely to enable system and software implementers to use Freescale Semiconductor products. There are no express or implied copyright licenses granted hereunder to design or fabricate any integrated circuits or integrated circuits based on the information in this document.

Freescale Semiconductor reserves the right to make changes without further notice to any products herein. Freescale Semiconductor makes no warranty, representation or guarantee regarding the suitability of its products for any particular purpose, nor does Freescale Semiconductor assume any liability arising out of the application or use of any product or circuit, and specifically disclaims any and all liability, including without limitation consequential or incidental damages. "Typical" parameters that may be provided in Freescale Semiconductor data sheets and/or specifications can and do vary in different applications and actual performance may vary over time. All operating parameters, including "Typicals", must be validated for each customer application by customer's technical experts. Freescale Semiconductor does not convey any license under its patent rights nor the rights of others. Freescale Semiconductor products are not designed, intended, or authorized for use as components in systems intended for surgical implant into the body, or other applications intended to support or sustain life, or for any other application in which the failure of the Freescale Semiconductor product could create a situation where personal injury or death may occur. Should Buyer purchase or use Freescale Semiconductor products for any such unintended or unauthorized application, Buyer shall indemnify and hold Freescale Semiconductor and its officers, employees, subsidiaries, affiliates, and distributors harmless against all claims, costs, damages, and expenses, and reasonable attorney fees arising out of, directly or indirectly, any claim of personal injury or death associated with such unintended or unauthorized use, even if such claim alleges that Freescale Semiconductor was negligent regarding the design or manufacture of the part.

Freescale and the Freescale logo are trademarks of Freescale Semiconductor, Inc., Reg. U.S. Pat. & Tm. Off. SafeAssure and Xtrinsic are trademarks of Freescale Semiconductor, Inc.

All other product or service names are the property of their respective owners.

© 2012 Freescale Semiconductor, Inc. All rights reserved.