

## Integrated Silicon Pressure Sensor, On-Chip Signal Conditioned, Temperature Compensated and Calibrated

The MP3V5004G series piezoresistive transducer is a state-of-the-art monolithic silicon pressure sensor designed for a wide range of applications, but particularly those employing a microcontroller or microprocessor with A/D inputs. This sensor combines a highly sensitive implanted strain gauge with advanced micromachining techniques, thin-film metallization, and bipolar processing to provide an accurate, high level analog output signal that is proportional to the applied pressure.

### Features

- Temperature Compensated from 10°C to 60°C
- Available in Gauge Surface Mount (SMT) Configuration
- Durable Thermoplastic (PPS) Package

## MP3V5004G Series

0 to 3.92 kPa (0 to 400 mm H<sub>2</sub>O)  
0.6 to 3.0 V Output

### Typical Applications

- Washing Machine Water Level
- Ideally Suited for Microprocessor or Microcontroller-Based Systems

### ORDERING INFORMATION

Device Name	Package Options	Case No.	# of Ports			Pressure Type			Device Marking
			None	Single	Dual	Gauge	Differential	Absolute	
<b>Small Outline Package (MP3V5004 Series)</b>									
MP3V5004GC6U	Rail	482A		•		•			MP3V5004G
MP3V5004GC6T1	Tape & Reel	482A		•		•			MP3V5004G
MP3V5004DP	Trays	1351			•		•		MP3V5004DP
MP3V5004GVP	Trays	1368		•		•			MP3V5004GV
MP3V5004GP	Trays	1369		•		•			MP3V5004GP

### SMALL OUTLINE PACKAGES

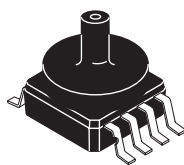

MP3V5004GC6U/6T1  
CASE 482A

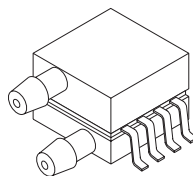

MP3V5004DP  
CASE 1351

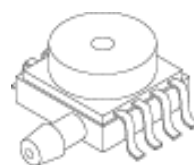

MP3V5004GVP  
CASE 1368

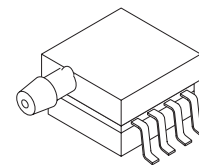

MP3V5004GP  
CASE 1369

## Operating Characteristics

**Table 1. Operating Characteristics** ( $V_S = 3.0$  Vdc,  $T_A = 25^\circ\text{C}$  unless otherwise noted,  $P_1 > P_2$ ).

Characteristic	Symbol	Min	Typ	Max	Unit	
Pressure Range	$P_{OP}$	0	—	3.92 400	kPa mm H <sub>2</sub> O	
Supply Voltage <sup>(1)</sup>	$V_S$	2.7	3.0	3.3	V <sub>DC</sub>	
Supply Current	$I_S$	—	—	10	mAdc	
Span at 306 mm H <sub>2</sub> O (3 kPa) <sup>(2)</sup>	$V_{FSS}$	—	1.8	—	V	
Offset <sup>(3) (4)</sup>	$V_{OFF}$	0.45	0.6	0.75	V	
Sensitivity	V/P	—	0.6 5.9	—	V/kPa mV/mm H <sub>2</sub> O	
Accuracy <sup>(4) (5)</sup>	0 to 100 mm H <sub>2</sub> O (10 to 60°C)	—	—	—	±1.5	%V <sub>FSS</sub>
	100 to 400 mm H <sub>2</sub> O (10 to 60°C)	—	—	—	±2.5	%V <sub>FSS</sub>

1. Device is ratiometric within this specified excitation range.
2. Span is defined as the algebraic difference between the output voltage at specified pressure and the output voltage at the minimum rated pressure.
3. Offset ( $V_{off}$ ) is defined as the output voltage at the minimum rated pressure.
4. Accuracy (error budget) consists of the following:
  - Linearity: Output deviation from a straight line relationship with pressure over the specified pressure range.
  - Temperature Hysteresis: Output deviation at any temperature within the operating temperature range, after the temperature is cycled to and from the minimum or maximum operating temperature points, with zero differential pressure applied.
  - Pressure Hysteresis: Output deviation at any pressure within the specified range, when this pressure is cycled to and from the minimum or maximum rated pressure, at 25°C.
  - Offset Stability: Output deviation, after 1000 temperature cycles, -30° to 100°C, and 1.5 million pressure cycles, with minimum rated pressure applied.
  - TcSpan: Output deviation over the temperature range of 10° to 60°C, relative to 25°C.
  - TcOffset: Output deviation with minimum rated pressure applied, over the temperature range of 10° to 60°C, relative to 25°C.
  - Variation from Nominal: The variation from nominal values, for Offset or Full Scale Span, as a percent of  $V_{FSS}$ , at 25°C.
5. Auto-Zero at Factory Installation: Due to the sensitivity of the MP3V5004G, external mechanical stresses and mounting position can affect the zero pressure output reading. Auto-zeroing is defined as storing the zero pressure output reading and subtracting this from the device's output during normal operations. Reference AN1636 for specific information. The specified accuracy assumes a maximum temperature change of ±5°C between auto-zero and measurement.

## Maximum Ratings

**Table 2. Maximum Ratings<sup>(1)</sup>**

Rating	Symbol	Value	Units
Maximum Pressure (P1 > P2)	$P_{MAX}$	16	kPa
Storage Temperature	$T_{STG}$	-30 to +100	°C
Operating Temperature	$T_A$	0 to +85	°C

1. Exposure beyond the specified limits may cause permanent damage or degradation to the device.

Figure 1 shows a block diagram of the internal circuitry integrated on a pressure sensor chip.

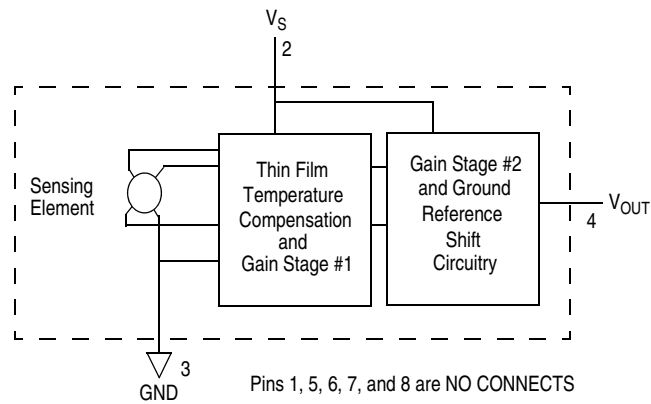

**Figure 1. Fully Integrated Pressure Sensor Schematic**

## On-chip Temperature Compensation and Calibration

The performance over temperature is achieved by integrating the shear-stress strain gauge, temperature compensation, calibration and signal conditioning circuitry onto a single monolithic chip.

Figure 2 illustrates the gauge configuration in the basic chip carrier (Case 482A). A fluorosilicone gel isolates the die surface and wire bonds from the environment, while allowing the pressure signal to be transmitted to the silicon diaphragm.

The MP3V5004G series sensor operating characteristics are based on the use of dry air as pressure media. Media, other than dry air, may have adverse effects on sensor performance and long-term reliability. Internal reliability and qualification test for dry air, and other media, are available

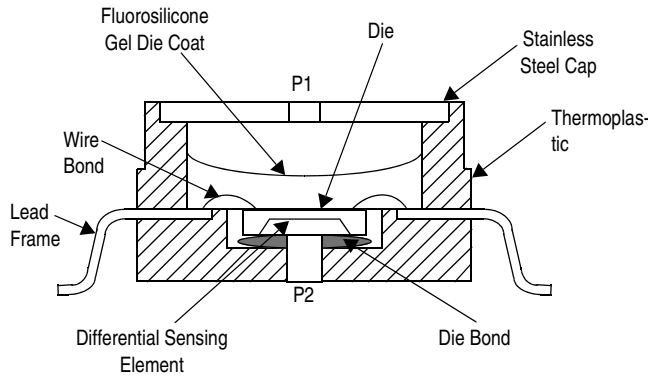

Figure 2. Cross Sectional Diagram SSOP (not to scale)

from the factory. Contact the factory for information regarding media tolerance in your application.

Figure 3 shows the recommended decoupling circuit for interfacing the output of the MP3V5004G to the A/D input of the microprocessor or microcontroller. Proper decoupling of the power supply is recommended.

Figure 4 shows the sensor output signal relative to pressure input. Typical, minimum and maximum output curves are shown for operation over a temperature range of 10°C to 60°C using the decoupling circuit shown in Figure 3. The output will saturate outside of the specified pressure range.

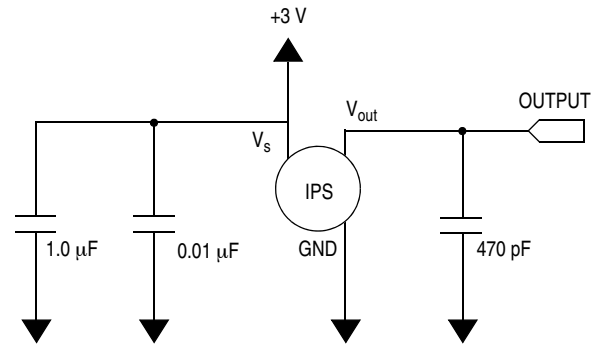

Figure 3. Recommended Power Supply Decoupling and Output Filtering.

(For additional output filtering, please refer to Application Note AN1646.)

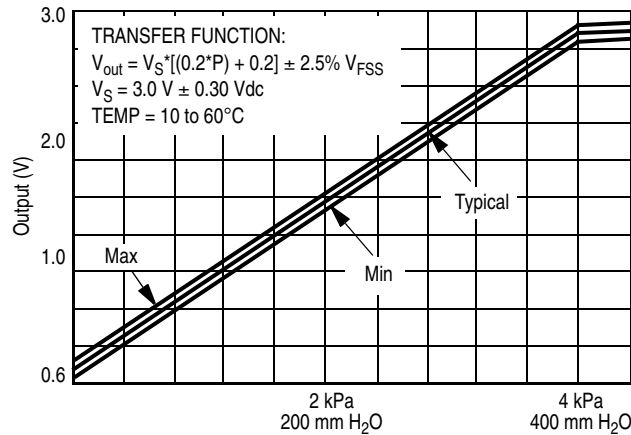

Figure 4. Output vs. Pressure Differential at  $\pm 2.5\% V_{FSS}$   
(See Note 5 in Operating Characteristics table)

**PRESSURE (P1)/VACUUM (P2) SIDE IDENTIFICATION TABLE**

Freescale Semiconductor designates the two sides of the pressure sensor as the Pressure (P1) side and the Vacuum (P2) side. The Pressure (P1) side is the side containing the silicone gel which isolates the die from the environment. The

Freescale Semiconductor pressure sensor is designed to operate with positive differential pressure applied,  $P1 > P2$ . The Pressure (P1) side may be identified by using the table below.

Part Number	Case Type	Pressure (P1) Side Identifier
MP3V5004GC6U/T1	482A	Side with Port Attached
MP3V5004GP	1369	Side with Port Attached
MP3V5004DP	1351	Side with Part Marking
MP3V5004GVP	1368	Stainless Steel Cap

**MINIMUM RECOMMENDED FOOTPRINT FOR SMALL OUTLINE PACKAGES**

Surface mount board layout is a critical portion of the total design. The footprint for the semiconductor package must be the correct size to ensure proper solder connection interface between the board and the package. With the correct pad geometry, the packages will self-align when subjected to a

solder reflow process. It is always recommended to fabricate boards with a solder mask layer to avoid bridging and/or shorting between solder pads, especially on tight tolerances and/or tight layouts.

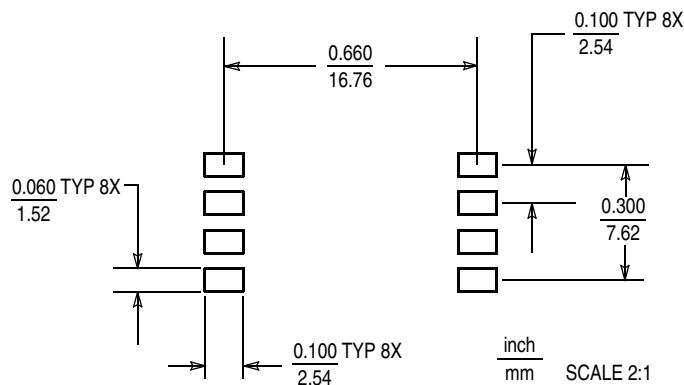

**Figure 5. SOP Footprint**

PACKAGE DIMENSIONS

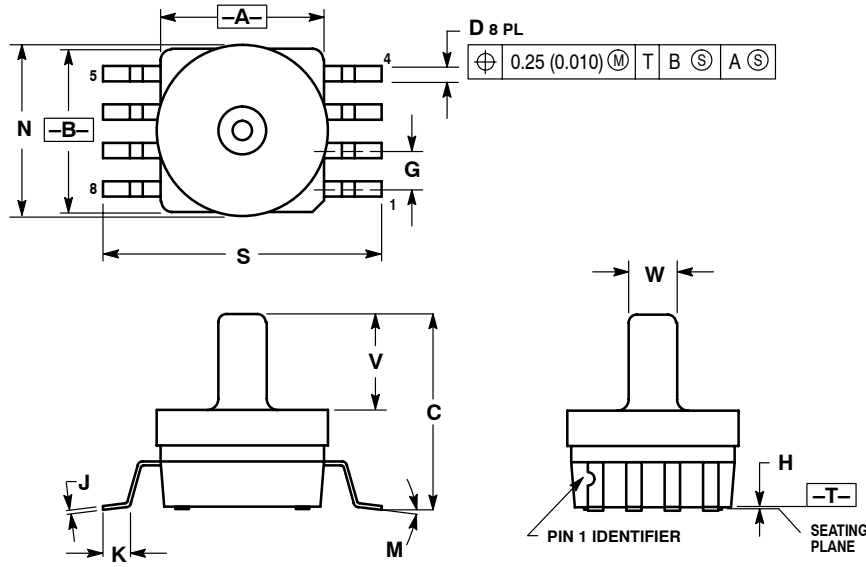

- NOTES:
1. DIMENSIONING AND TOLERANCING PER ANSI Y14.5M, 1982.
  2. CONTROLLING DIMENSION: INCH.
  3. DIMENSION A AND B DO NOT INCLUDE MOLD PROTRUSION.
  4. MAXIMUM MOLD PROTRUSION 0.15 (0.006).
  5. ALL VERTICAL SURFACES 5° TYPICAL DRAFT.

DIM	INCHES		MILLIMETERS	
	MIN	MAX	MIN	MAX
A	0.415	0.425	10.54	10.79
B	0.415	0.425	10.54	10.79
C	0.500	0.520	12.70	13.21
D	0.038	0.042	0.96	1.07
G	0.100 BSC		2.54 BSC	
H	0.002	0.010	0.05	0.25
J	0.009	0.011	0.23	0.28
K	0.061	0.071	1.55	1.80
M	0°	7°	0°	7°
N	0.444	0.448	11.28	11.38
S	0.709	0.725	18.01	18.41
V	0.245	0.255	6.22	6.48
W	0.115	0.125	2.92	3.17

CASE 482A-01  
ISSUE A  
SMALL OUTLINE PACKAGE

PACKAGE DIMENSIONS

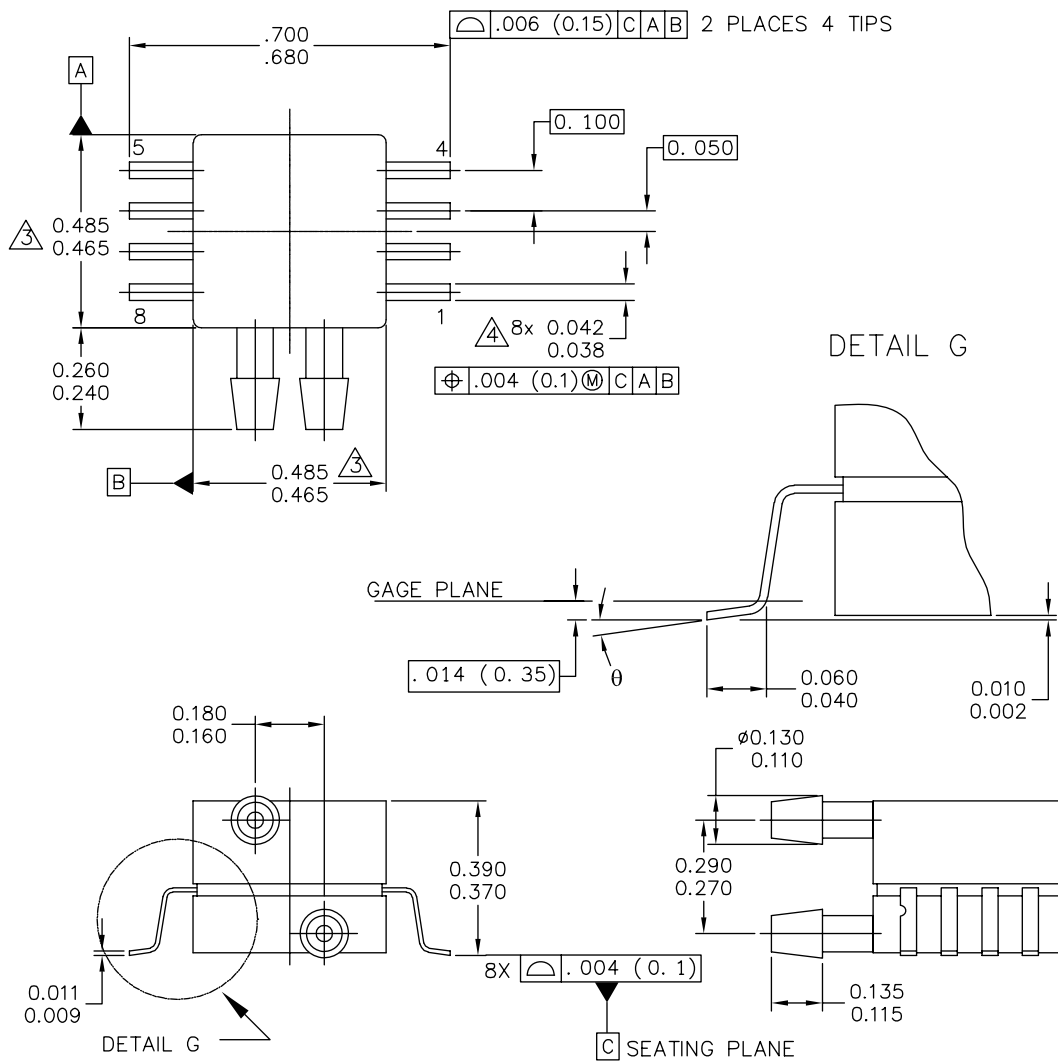

© FREESCALE SEMICONDUCTOR, INC. ALL RIGHTS RESERVED.	<b>MECHANICAL OUTLINE</b>		PRINT VERSION NOT TO SCALE
	TITLE: 8 LD SNSR, DUAL PORT		DOCUMENT NO: 98ASA99255D REV: A
		CASE NUMBER: 1351-01	27 JUL 2005
		STANDARD: NON-JEDEC	

**CASE 1351-01  
ISSUE A  
SMALL OUTLINE PACKAGE**

**PACKAGE DIMENSIONS**

NOTES:

1. CONTROLLING DIMENSION: INCH
2. INTERPRET DIMENSIONS AND TOLERANCES PER ASME Y14.5M-1994.
3. DIMENSIONS DO NOT INCLUDE MOLD FLASH OR PROTRUSIONS. MOLD FLASH AND PROTRUSIONS SHALL NOT EXCEED .006 PER SIDE.
4. DIMENSION DOES NOT INCLUDE DAMBAR PROTRUSION. ALLOWABLE DAMBAR PROTRUSION SHALL BE .008 MAXIMUM.

STYLE 1:

PIN 1: GND  
 PIN 2: +Vout  
 PIN 3: Vs  
 PIN 4: -Vout  
 PIN 5: N/C  
 PIN 6: N/C  
 PIN 7: N/C  
 PIN 8: N/C

STYLE 2:

PIN 1: N/C  
 PIN 2: Vs  
 PIN 3: GND  
 PIN 4: Vout  
 PIN 5: N/C  
 PIN 6: N/C  
 PIN 7: N/C  
 PIN 8: N/C

© FREESCALE SEMICONDUCTOR, INC. ALL RIGHTS RESERVED.	<b>MECHANICAL OUTLINE</b>	PRINT VERSION NOT TO SCALE	
TITLE:  8 LD SNSR, DUAL PORT	DOCUMENT NO: 98ASA99255D	REV: A	
	CASE NUMBER: 1351-01	27 JUL 2005	
	STANDARD: NON-JEDEC		

**CASE 1351-01  
 ISSUE A  
 SMALL OUTLINE PACKAGE**



PACKAGE DIMENSIONS

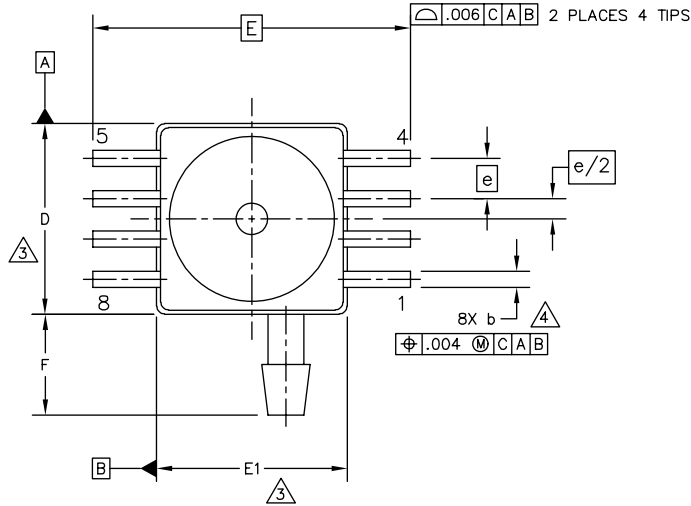

0.216

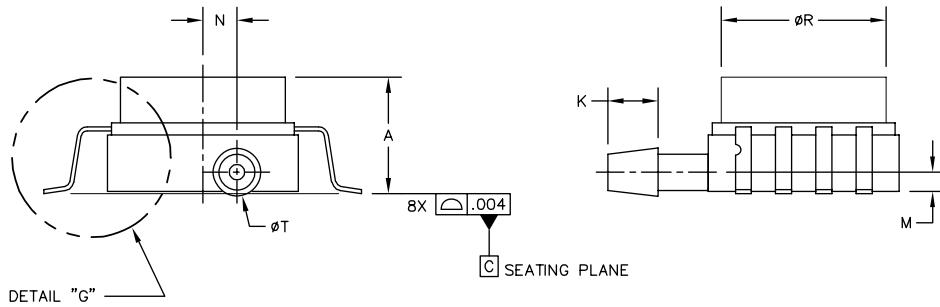

© FREESCALE SEMICONDUCTOR, INC. ALL RIGHTS RESERVED.	<b>MECHANICAL OUTLINE</b>	PRINT VERSION NOT TO SCALE	
TITLE:  8 LD SOP, GVP	DOCUMENT NO: 98ASA99302D	REV: C	
	CASE NUMBER: 1368-01	18 DEC 2008	
	STANDARD: NON-JEDEC		

**CASE 1368-01  
ISSUE C  
SMALL OUTLINE PACKAGE**

PACKAGE DIMENSIONS

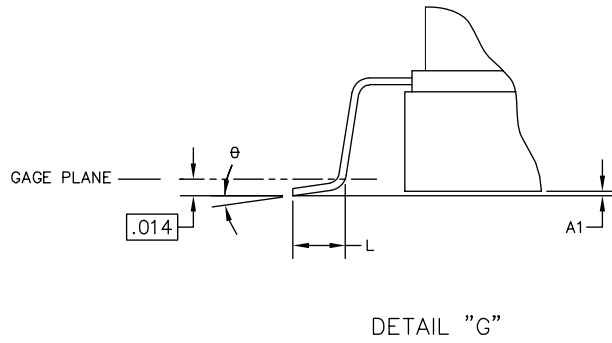

© FREESCALE SEMICONDUCTOR, INC. ALL RIGHTS RESERVED.	<b>MECHANICAL OUTLINE</b>	PRINT VERSION NOT TO SCALE	
TITLE:  8 LD SOP, GVP	DOCUMENT NO: 98ASA99302D	REV: C	
	CASE NUMBER: 1368-01	18 DEC 2008	
	STANDARD: NON-JEDEC		

**CASE 1368-01  
ISSUE C  
SMALL OUTLINE PACKAGE**

**PACKAGE DIMENSIONS**

NOTES:

1. CONTROLLING DIMENSION: INCH
2. INTERPRET DIMENSIONS AND TOLERANCES PER ASME Y14.5M-1994.

⚠ THIS DIMENSIONS DOES NOT INCLUDE MOLD FLASH OR PROTRUSIONS. MOLD FLASH AND PROTRUSIONS SHALL NOT EXCEED .006 PER SIDE.

⚠ THIS DIMENSION DOES NOT INCLUDE DAMBAR PROTRUSION. ALLOWABLE DAMBAR PROTRUSION SHALL BE .008 MAXIMUM.

STYLE 1:

PIN 1: GND  
 PIN 2: +Vout  
 PIN 3: Vs  
 PIN 4: -Vout  
 PIN 5: N/C  
 PIN 6: N/C  
 PIN 7: N/C  
 PIN 8: N/C

STYLE 2:

PIN 1: N/C  
 PIN 2: Vs  
 PIN 3: GND  
 PIN 4: Vout  
 PIN 5: N/C  
 PIN 6: N/C  
 PIN 7: N/C  
 PIN 8: N/C

DIM	INCHES		MILLIMETERS		DIM	INCHES		MILLIMETERS	
	MIN	MAX	MIN	MAX		MIN	MAX	MIN	MAX
A	.280	.300	7.11	7.62	R	.405	.415	10.28	10.54
A1	.002	.010	0.05	0.25	θ	0°	7°	0°	7°
b	.038	.042	0.96	1.07	-	---	---	---	---
D	.465	.485	11.81	12.32	-	---	---	---	---
E	.690 BSC		17.52 BSC		-	---	---	---	---
E1	.465	.485	11.81	12.32	-	---	---	---	---
e	.100 BSC		2.54 BSC		-	---	---	---	---
F	.240	.260	6.10	6.60	-	---	---	---	---
K	.115	.135	2.92	3.43	-	---	---	---	---
L	.040	.060	1.02	1.52	-	---	---	---	---
M	.035	.055	0.89	1.39	-	---	---	---	---
N	.075	.095	1.90	2.41	-	---	---	---	---
P	.009	.011	0.23	0.28	-	---	---	---	---
T	.110	.130	2.79	3.30	-	---	---	---	---
© FREESCALE SEMICONDUCTOR, INC. ALL RIGHTS RESERVED.			<b>MECHANICAL OUTLINE</b>			PRINT VERSION NOT TO SCALE			
TITLE:  8 LD SOP, GVP					DOCUMENT NO: 98ASA99302D			REV: C	
					CASE NUMBER: 1368-01			18 DEC 2008	
					STANDARD: NON-JEDEC				

**CASE 1368-01  
 ISSUE C  
 SMALL OUTLINE PACKAGE**

PACKAGE DIMENSIONS

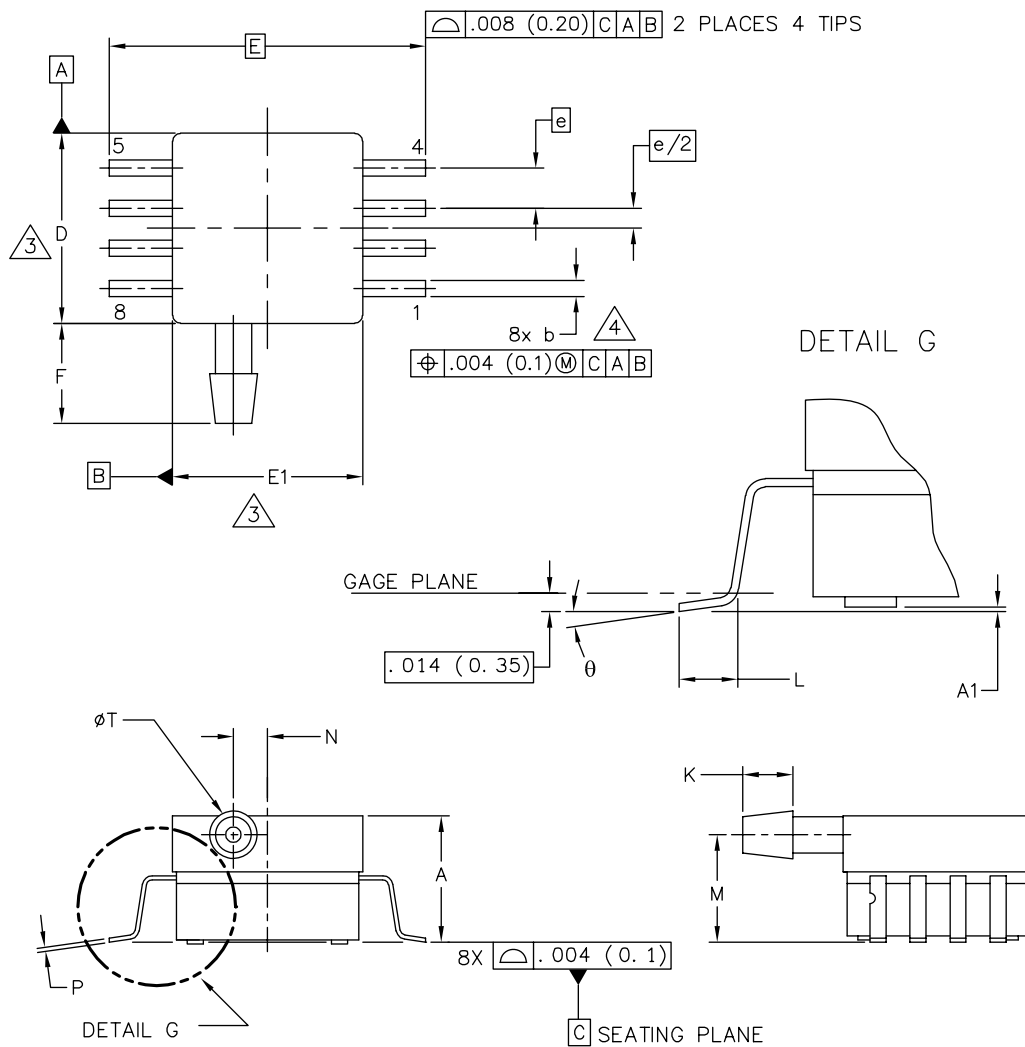

© FREESCALE SEMICONDUCTOR, INC. ALL RIGHTS RESERVED.	<b>MECHANICAL OUTLINE</b>	PRINT VERSION NOT TO SCALE
TITLE: 8 LD SOP, SIDE PORT	DOCUMENT NO: 98ASA99303D	REV: B
	CASE NUMBER: 1369-01	24 MAY 2005
	STANDARD: NON-JEDEC	

**CASE 1369-01  
ISSUE B  
SMALL OUTLINE PACKAGE**

## PACKAGE DIMENSIONS

## NOTES:

1. CONTROLLING DIMENSION: INCH

2. INTERPRET DIMENSIONS AND TOLERANCES PER ASME Y14.5M-1994.

3. DIMENSIONS DO NOT INCLUDE MOLD FLASH OR PROTRUSIONS.  
MOLD FLASH AND PROTRUSIONS SHALL NOT EXCEED .006 (0.152) PER SIDE.

4. DIMENSION DOES NOT INCLUDE DAMBAR PROTRUSION. ALLOWABLE DAMBAR  
PROTRUSION SHALL BE .008 (0.203) MAXIMUM.

DIM	INCHES		MILLIMETERS		DIM	INCHES		MILLIMETERS	
	MIN	MAX	MIN	MAX		MIN	MAX	MIN	MAX
A	.300	.330	7.11	7.62	θ	0°	7°	0°	7°
A1	.002	.010	0.05	0.25	-	---	---	---	---
b	.038	.042	0.96	1.07	-	---	---	---	---
D	.465	.485	11.81	12.32	-	---	---	---	---
E	.717 BSC		18.21 BSC		-	---	---	---	---
E1	.465	.485	11.81	12.32	-	---	---	---	---
e	.100 BSC		2.54 BSC		-	---	---	---	---
F	.245	.255	6.22	6.47	-	---	---	---	---
K	.120	.130	3.05	3.30	-	---	---	---	---
L	.061	.071	1.55	1.80	-	---	---	---	---
M	.270	.290	6.86	7.36	-	---	---	---	---
N	.080	.090	2.03	2.28	-	---	---	---	---
P	.009	.011	0.23	0.28	-	---	---	---	---
T	.115	.125	2.92	3.17	-	---	---	---	---
© FREESCALE SEMICONDUCTOR, INC. ALL RIGHTS RESERVED.			<b>MECHANICAL OUTLINE</b>			PRINT VERSION NOT TO SCALE			
TITLE:  8 LD SOP, SIDE PORT					DOCUMENT NO: 98ASA99303D			REV: B	
					CASE NUMBER: 1369-01			24 MAY 2005	
					STANDARD: NON-JEDEC				

**CASE 1369-01  
ISSUE B  
SMALL OUTLINE PACKAGE**

## **How to Reach Us:**

### **Home Page:**

[www.freescale.com](http://www.freescale.com)

### **Web Support:**

<http://www.freescale.com/support>

### **USA/Europe or Locations Not Listed:**

Freescale Semiconductor, Inc.  
Technical Information Center, EL516  
2100 East Elliot Road  
Tempe, Arizona 85284  
1-800-521-6274 or +1-480-768-2130  
[www.freescale.com/support](http://www.freescale.com/support)

### **Europe, Middle East, and Africa:**

Freescale Halbleiter Deutschland GmbH  
Technical Information Center  
Schatzbogen 7  
81829 Muenchen, Germany  
+44 1296 380 456 (English)  
+46 8 52200080 (English)  
+49 89 92103 559 (German)  
+33 1 69 35 48 48 (French)  
[www.freescale.com/support](http://www.freescale.com/support)

### **Japan:**

Freescale Semiconductor Japan Ltd.  
Headquarters  
ARCO Tower 15F  
1-8-1, Shimo-Meguro, Meguro-ku,  
Tokyo 153-0064  
Japan  
0120 191014 or +81 3 5437 9125  
[support.japan@freescale.com](mailto:support.japan@freescale.com)

### **Asia/Pacific:**

Freescale Semiconductor China Ltd.  
Exchange Building 23F  
No. 118 Jianguo Road  
Chaoyang District  
Beijing 100022  
China  
+86 010 5879 8000  
[support.asia@freescale.com](mailto:support.asia@freescale.com)

### **For Literature Requests Only:**

Freescale Semiconductor Literature Distribution Center  
1-800-441-2447 or +1-303-675-2140  
Fax: +1-303-675-2150  
[LDCForFreescaleSemiconductor@hibbertgroup.com](mailto:LDCForFreescaleSemiconductor@hibbertgroup.com)

Information in this document is provided solely to enable system and software implementers to use Freescale Semiconductor products. There are no express or implied copyright licenses granted hereunder to design or fabricate any integrated circuits or integrated circuits based on the information in this document.

Freescale Semiconductor reserves the right to make changes without further notice to any products herein. Freescale Semiconductor makes no warranty, representation or guarantee regarding the suitability of its products for any particular purpose, nor does Freescale Semiconductor assume any liability arising out of the application or use of any product or circuit, and specifically disclaims any and all liability, including without limitation consequential or incidental damages. "Typical" parameters that may be provided in Freescale Semiconductor data sheets and/or specifications can and do vary in different applications and actual performance may vary over time. All operating parameters, including "Typicals", must be validated for each customer application by customer's technical experts. Freescale Semiconductor does not convey any license under its patent rights nor the rights of others. Freescale Semiconductor products are not designed, intended, or authorized for use as components in systems intended for surgical implant into the body, or other applications intended to support or sustain life, or for any other application in which the failure of the Freescale Semiconductor product could create a situation where personal injury or death may occur. Should Buyer purchase or use Freescale Semiconductor products for any such unintended or unauthorized application, Buyer shall indemnify and hold Freescale Semiconductor and its officers, employees, subsidiaries, affiliates, and distributors harmless against all claims, costs, damages, and expenses, and reasonable attorney fees arising out of, directly or indirectly, any claim of personal injury or death associated with such unintended or unauthorized use, even if such claim alleges that Freescale Semiconductor was negligent regarding the design or manufacture of the part.

Freescale and the Freescale logo are trademarks of Freescale Semiconductor, Inc., Reg. U.S. Pat. & Tm. Off. All other product or service names are the property of their respective owners.

© Freescale Semiconductor, Inc. 2010. All rights reserved.

