



# Heyco-Flex™ Liquid Tight Conduit Fittings

## 90° Sweep, NPT Hubs

For Flexible, Nonmetallic Liquid Tight Heyco-Flex™ I Conduit and Heyco-Flex™ II Tubing



- Smooth internal surfaces for easier wire installation around corner angles.
- No disassembly required. Instead, the installer simply pushes the conduit or tubing onto the ferrule, then tightens the domed sealing nut. This completed assembly can then be secured in the panel by the locknut or into an NPT threaded hole.
- Convex ferrule ensures liquid tight seal.
- No threading of the conduit or tubing is required to install. This eliminates the possibility of cutting the conduit and creating leak paths.
- Complete conduit/connector system is reusable. Conduit will not wind tight onto the connector during assembly and can be easily removed by pulling while turning in a clockwise direction.
- Lower installed cost.
- Multiple sizes for use with Heyco-Flex Conduit and Tubing. See pages 2-1 and 2-2.
- Protection class IP 68 up to 70 psi (5 bar) water pressure.
- Suitable for indoor/outdoor use; for original equipment manufacturers or field installers.
- Resist salt water, weak acids, gasoline, alcohol, oil, grease, and common solvents. (This feature is not assessed by UL certification and testing.)
- Use of a sealing washer may be required for wet locations. See page 2-13 and 2-14.
- If using a tapped hole, Teflon® tape is needed on the threads of the connector, for all other applications an O-ring and Locknut are needed to attain liquid tight.
- Black connectors up to 1” provided with nylon locknut, packed separately. Larger than 1” provided with O-ring and metal locknut.
- Gray connectors provided with assembled O-ring and metal locknut.
- See pages 2-11 and 2-12 for locknuts.
- See pages 2-14 and 2-15 for sealing washers and O-rings.

FITS CONDUIT/TUBING TRADE SIZE	PART NO.		DESCRIPTION	THREAD SIZE	PART DIMENSIONS BODY AND SEALING UNIT							
	Black	Gray			A		B		C		D	
					Clearance Hole	in. mm.	Max. O.A. Height	in. mm.	Max. O.A. Length	in. mm.	Thread Length	in. mm.
3/8	8423	8424	HFC 3/8-90R	1/2 NPT	.875	22,2	1.982	50,3	2.912	73,9	.520	13,2
1/2	8425	8426	HFC 1/2-90R									
3/4	8427	8428	HFC 3/4-90R	3/4 NPT	1.109	28,1	2.293	58,2	3.172	80,5	.520	13,2
1	8412	8413	HFC 1-90R	1 NPT	1.375	34,9	2.833	71,9	3.964	100,6	.690	17,5
1-1/4	8652	8653	HFC 1-1/4-90R	1-1/4 NPT	1.734	44,0	4.100	104,1	4.725	104,1	.760	19,3
1-1/2	8654	8655	HFC 1-1/2-90R	1-1/2 NPT	1.984	50,4	4.750	120,7	5.200	132,1	.800	20,3
2	8656	8657	HFC 2-90R	2 NPT	2.469	62,7	5.420	137,7	5.800	147,3	.860	21,8

Standard color black or gray.

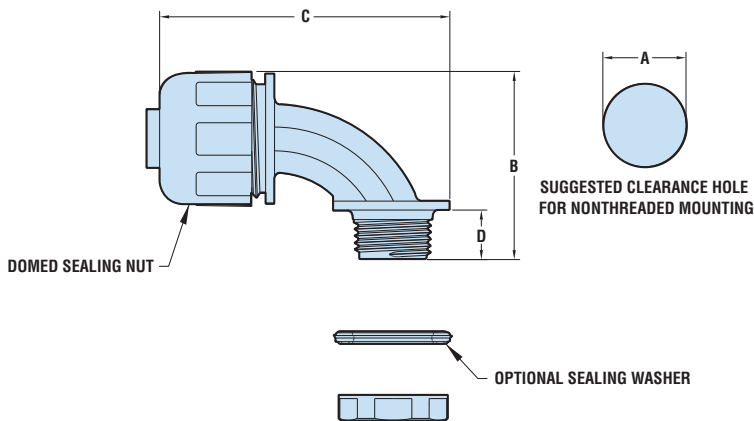

<b>Material Certifications</b>	Nylon 6/6 UL Listed under Underwriters' Laboratories File E28430 SP Certified by Canadian Standards Association File 84579 and 81067
<b>Flammability Rating</b>	94V-2
<b>Material Temperature Index</b>	Maximum temperature on part not to exceed 221°F (105°C)
<b>IP Rating</b>	IP 68 up to 70 psi (5 bar) water pressure