



## Heyco® .187" Diameter Ground Pins - Male

For Heyco Padded and Full Thickness Blades, see pages 8-29 thru 8-34

**All Series:**

- **187" (4,7 mm)** Outside Diameter.
- Conductor crimp ears only.
- Available only in continuous strip form except **Part No. 5877** available Bulk only.
- Overall length options of 1.25" (31,8 mm), 1.35" (34,3 mm), and 1.37" (34,8 mm).
- **Series 186 and 186-L** feature a 90° “knee” section for **strain relief** and assembly orientation.

Overall Length in.	PART DATA		PART NO.	Die**	APPLICATION TOOLING*			
	AWG Range	Material			Feeds	Tool Packs	Crimp Punch	Anvil
<b>188 Series</b>								
1.35	18-12	Brass	<b>5922</b>	5922UXX5	Left to Right	B362L/B363L	C360	C629
		Tin-Pl	<b>5921</b>	5921UXX5				
		Brass	<b>5923</b>	5923UXX5	Right to Left	B362R/B363R	C360	C365
		Tin-Pl	<b>5924</b>	5924UXX5				
<b>186 Series</b>								
1.25	18-14	Brass	<b>5877</b>	-	Bulk	-	-	-
		Brass	<b>5879</b>	5879UXX5	Left to Right	B360L/B361L	C001	C009
	Tin-Pl	<b>5883</b>	5883UXX5					
	14-10	Brass	<b>5880</b>	5880UXX5	Right to Left	B360R/B361R		
Tin-Pl		<b>5875</b>	5875UXX5					
<b>186-L Series</b>								
1.37	18-14	Brass	<b>5889</b>	5889UXX5	Left to Right	B360L/ B361L	C001	C009
	14-10	Brass	<b>5888</b>	5888UXX5				
	18-14	Brass	<b>5886</b>	5886UXX5	Right to Left	B360R/B361R		
		Tin-Pl	<b>5887</b>	5887UXX5				
14-10	Brass	<b>5884</b>	5884UXX5					
		Tin-Pl	<b>5885</b>	5885UXX5				

\* Heyco high volume Application Tooling, designed for 3-5 ton presses - see page 8-57.

Heyco Mini Applicators, designed for 1.5-3 ton bench top presses, are available - see page 8-57.

\*\* “XX” represents Wire Gauge. Please specify Wire Gauge when ordering.

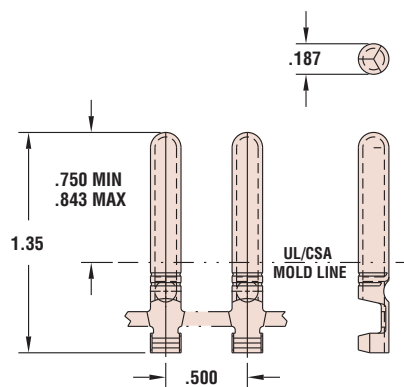

188 Series

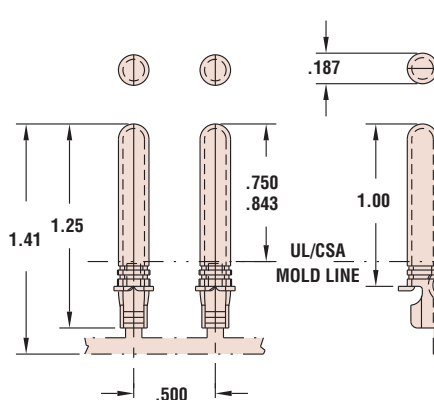

186 Series

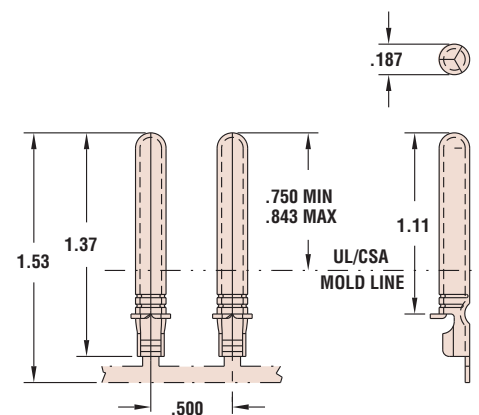

186-L Series

Quick Specs

**Materials**

**Alloy 260 Brass** (70% Cu, 30% Zn. Higher Cu content resists dezincification)  
Tin-Pl = Brass, Tin plated before or after stamping