



Heyco® Heavy Duty Ground Pins-Male

For Heavy Duty Blades, see pages 8-27 & 8-28

Both Series:

- Suitable for use in straight and right angle plugs.
- On termination, the strip and crimping die bends Angled Shape parts to 90°.
- All 250 and 312 Series are compatible with Heyco Heavy Duty Blades.

250 Series:

- a.k.a. “Travel Trailer” Grounding Pin.
- 30 Amp rating.
- Conductor crimp ears only.

312 Series:

- Heavy Duty Grounding Pin.
- 30, 50 and 60 Amp rating.
- Conductor crimp ears only.

Overall Length in.	PART DATA			PART NO.		APPLICATION TOOLING*				
	Shape	AWG Range	Material		Die**	Feeds	Tool Packs	Crimp Punch	Anvil	
250 Series - .250" (6,4 mm) outside diameter										
1.88	Angled	14-10	Brass	5930	5930SXX5	Bulk	-	OB51	OB52	
	Flat	14-10	Tin-Pl	5931	5931SXX5					
1.91	Flat	14-10	Brass	5933	5933UXX5	Left to Right Right to Left	-	C901	0892	
			Brass	5932	5932UXX5					
312 Series - .312" (7,9 mm) outside diameter										
2.48	Angled	10-6	Brass	6249	6249SXX5	Bulk	-	OB51	OB53	
			Tin-Pl	6250	6250SXX5					
			Post-Ni	6251	6251SXX5					

* Use the Heyco Universal Applicator Die (indicated by “S” or “U” n the Die Part No.), page 8-57.

** “XX” represents Wire Gauge. Please specify Wire Gauge when ordering.

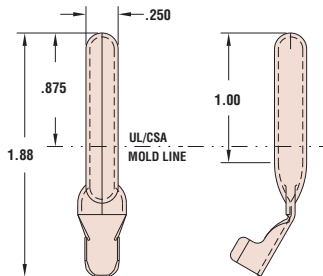

250 Series Angled

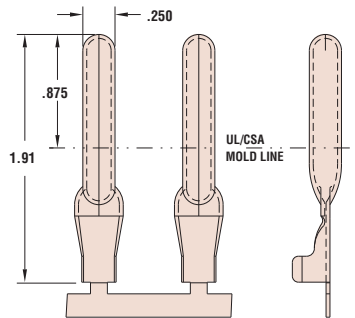

250 Series Flat

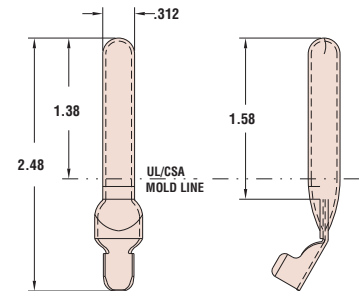

312 Series

Quick Specs

Materials

Alloy 260 Brass (70% Cu, 30% Zn. Higher Cu content resists dezincification)
 Tin-Pl = Brass, Tin plated before or after stamping
 Post-Ni = Brass, Nickel plated after stamping