

REVISIONS			
REV.	DESCRIPTION	DATE	APPROVED
C	REV PER ECN ED9035	MAR31/09	A.G.

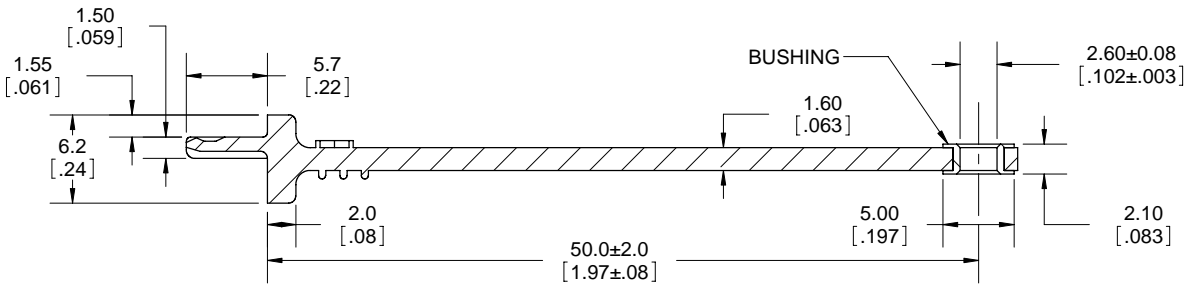

SECTION A-A

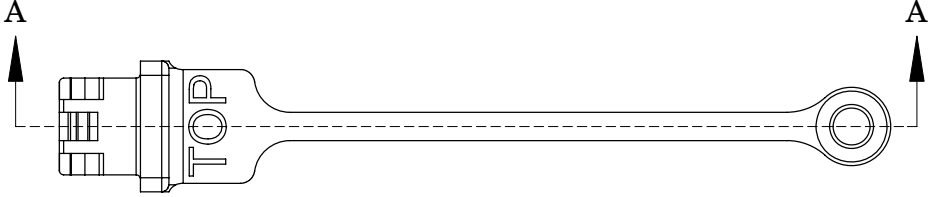
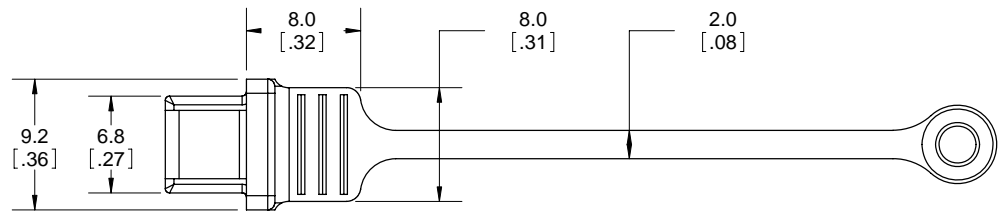
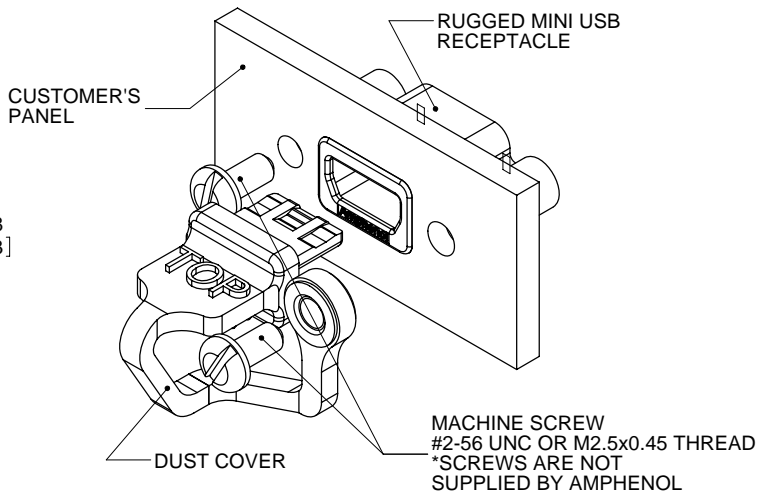

NOTES

- MATERIAL:
 - RUBBER: SILICONE RUBBER, UL94V-0, SEE CHART FOR COLOUR
 - BUSHING: BRASS ALLOY, NICKEL PLATED.
- PART IS RoHS COMPLIANT PER EU DIRECTIVE 2002/95/EC AND AMENDMENTS.

AMPHENOL PART NUMBER	COLOUR
MUSB-2E151-005BP	GREY
MUSB-2E151-015BP	BLACK

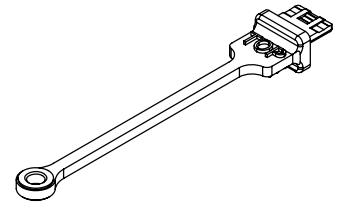

DO NOT SCALE DRAWING



THIS DOCUMENT CONTAINS PROPRIETARY INFORMATION AND SUCH INFORMATION MAY NOT BE DISCLOSED TO OTHERS FOR ANY PURPOSE OR USED FOR MANUFACTURING PURPOSES WITHOUT PERMISSION FROM AMPHENOL CANADA CORP.

UNLESS OTHERWISE SPECIFIED DIMENSIONS ARE IN MILLIMETERS [INCHES] TOLERANCES ARE: DECIMALS ANGLES XX± 0.3 ± 1° X.XX± 0.10	APPROVALS	DATE
	DRAWN LAWRENCE KIM	JUNE04/07
	DESIGNED LAWRENCE KIM	JUNE04/07
	CHECKED	
MATERIAL AND FINISH N/A	QA APPD	
REF X	IE APPD	
CODE IDENT NO. 03554	DWG APPD A.GREEN	JUNE04/07

Amphenol Canada Corp.

TITLE
**MUSB SERIES
DUST COVER FOR MINI
USB, RoHS COMPLIANT**

SIZE A4	DWG. NO. P-MUSB-2E151-0X5BP	REV. C
SCALE 2:1	PROJECT	SHEET 1 OF 1