

REVISIONS				
SYM	ZONE	ECN, ERN NO.	DATE	APPRD.
A		PROPOSAL	MAY 8/08	L.CHAN
B		FIX THE PACKING QUANTITY	MAR 13/13	L.CHAN

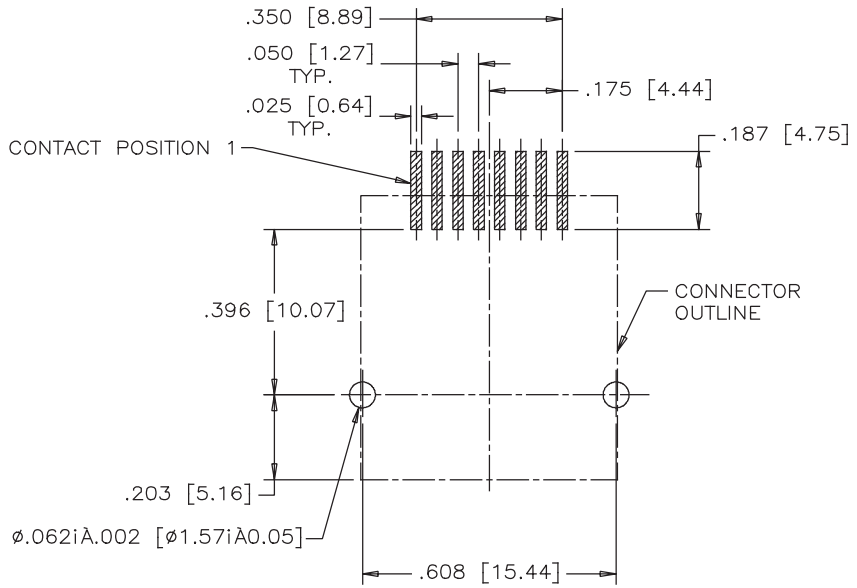
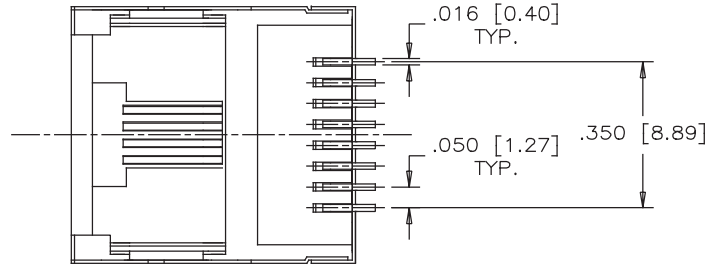

RECOMMENDED P.C.B. LAYOUT
(COMPONENT SIDE OF BOARD)

- NOTES:
- MATERIALS:
 - HOUSING: HIGH TEMPERATURE RESISTANT NYLON. FLAMMABILITY RATING UL 94V-0
COLOUR: BLACK
 - CONTACTS: PHOSPHOR BRONZE
 - PLATING: GOLD PLATED REFER TO PART NUMBER ON MATING SURFACES.
50 U" [1.27 MICRONS] MIN. NICKEL UNDERPLATE.
100 U" [2.54 MICRONS] MIN. MATTE-TIN ON CONTACT TAILS.
 - SHIELD: COPPER ALLOY, NICKEL PLATED WITH PURE-TIN DIPPED ON SOLDER TAIL
 - COPLANARITY SPECIFICATION:
WITH THE MODULAR JACK SITTING ON A LEVEL SURFACE, THE MAXIMUM GAP BETWEEN THE LEVEL SURFACE AND ALL TERMINAL TAILS AND BOTH FITTING NAILS IS .004 [0.10].

AMPHENOL PART NO.: RJLSE-4X381-01T

- GOLD PLATING
- 0 = 06 u"
 - 1 = 15 u"
 - 2 = 30 u"
 - 3 = 50 u"

DRAWN	J.OUYANG	DATE	MAY 8/08
DESIGNED	MT.CHAN	DATE	MAY 8/08
CHECKED	L.CHAN	DATE	MAY 8/08
I. E. APPRD.			
Q. A. APPRD.			
DWG. APPRD.			
ENG. REL. NO.			
REF.			
DIMENSIONS ARE IN		CODE ID. NO.	
INCHES [mm]		03554	

Amphenol Canada Corp.			
TITLE SURFACE MOUNT MODULAR JACK ,8 POSITION, 8 CONTACTS, WITH SHIELD,WITH TAPE & REEL PACKAGING-ROHS COMPLIANT			
DWG	DRAWING NO.	REV.	
	P-RJLSE-4X381-01T	B	
SCALE	WT.	SURF.	SHEET 1 OF 2

THIS DOCUMENT CONTAINS PROPRIETARY INFORMATION AND SUCH INFORMATION MAY NOT BE DISCLOSED TO OTHERS FOR ANY PURPOSE OR USED FOR MANUFACTURING PURPOSES WITHOUT WRITTEN PERMISSION FROM AMPHENOL CANADA CORP.



		REVISIONS		
SYM	ZONE	ECN, ERN NO.	DATE	APPRD.
A		PROPOSAL	MAY 8/08	L.CHAN
B		FIX THE PACKING QUANTITY	MAR 13/13	L.CHAN

← DIRECTION OF CONNECTOR LOADED INTO MACHINE.
LEADS FACING FRONT SIDE

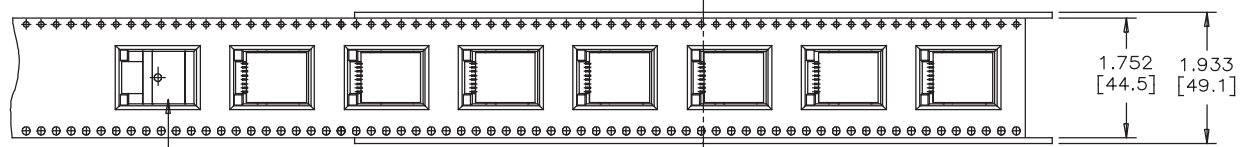

SEE DETAIL 'A' BELOW FOR CARRIER TAPE DETAIL

TOP VIEW
(COVER TAPE NOT SHOWN)
(SHOWN WITH RJLSE 8 POSITION CONNECTOR)

PACKAGING NOTES:

- ONE REEL SHOULD HOLD 100 CONNECTORS.
- 25 EMPTY CAVITIES FOR CARRIER TAPE LEADER & 10 EMPTY CAVITIES FOR CARRIER TAPE TRAILER.
- A FULLY LOADED CARTON SHOULD CONTAIN 5 REELS (500 PCS) OF CONNECTORS.

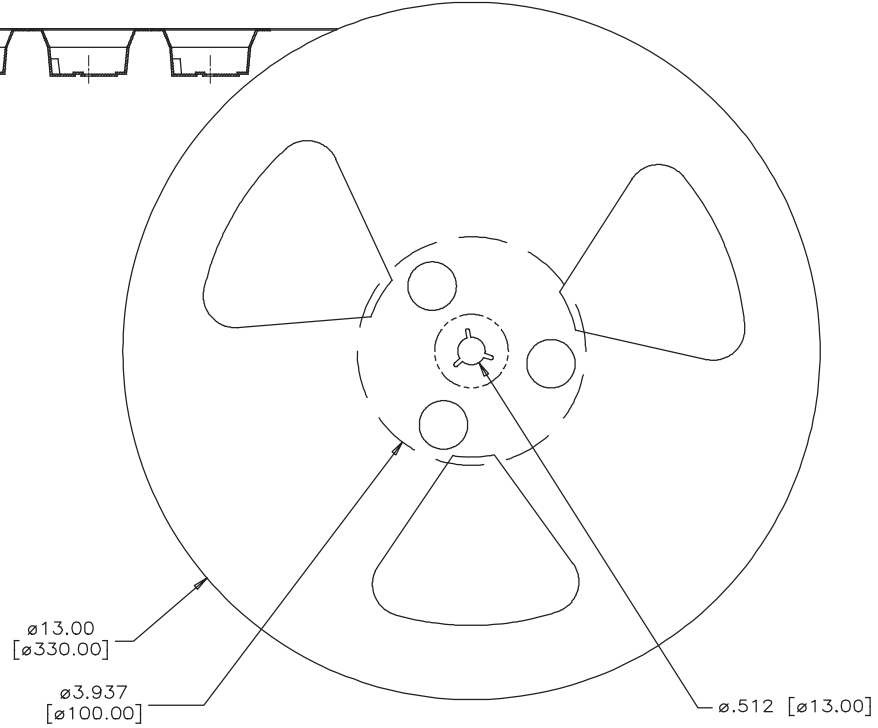
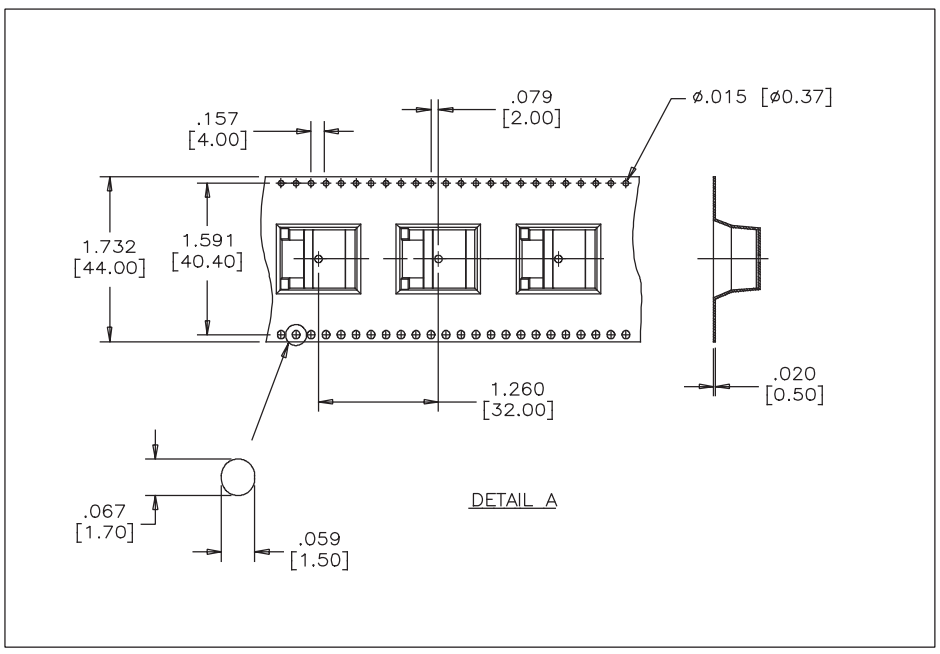
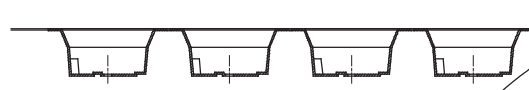

DRAWN	J.OUYANG	DATE	MAY 8/08
DESIGNED	MT.CHAN	DATE	MAY 8/08
CHECKED	L.CHAN	DATE	MAY 8/08
I. E. APPRD.			
Q. A. APPRD.			
DWG. APPRD.			
ENG. REL. NO.			
REF.			
DIMENSIONS ARE IN	CODE ID. NO.		
INCHES [mm]	03554		

Amphenol Canada Corp.			
TITLE SURFACE MOUNT MODULAR JACK ,8 POSITION, 8 CONTACTS, WITH SHIELD,WITH TAPE & REEL PACKAGING-ROHS COMPLIANT			
DWG	DRAWING NO.		REV.
	P-RJLSE-4X381-01T		B
SCALE	NTS	WT. -----	SURF. -----
			SHEET 2 OF 2

THIS DOCUMENT CONTAINS PROPRIETARY INFORMATION AND SUCH INFORMATION MAY NOT BE DISCLOSED TO OTHERS FOR ANY PURPOSE OR USED FOR MANUFACTURING PURPOSES WITHOUT WRITTEN PERMISSION FROM AMPHENOL CANADA CORP.