

REV.	DATE	DESCRIPTION
NC	06/11/02	INITIAL RELEASE

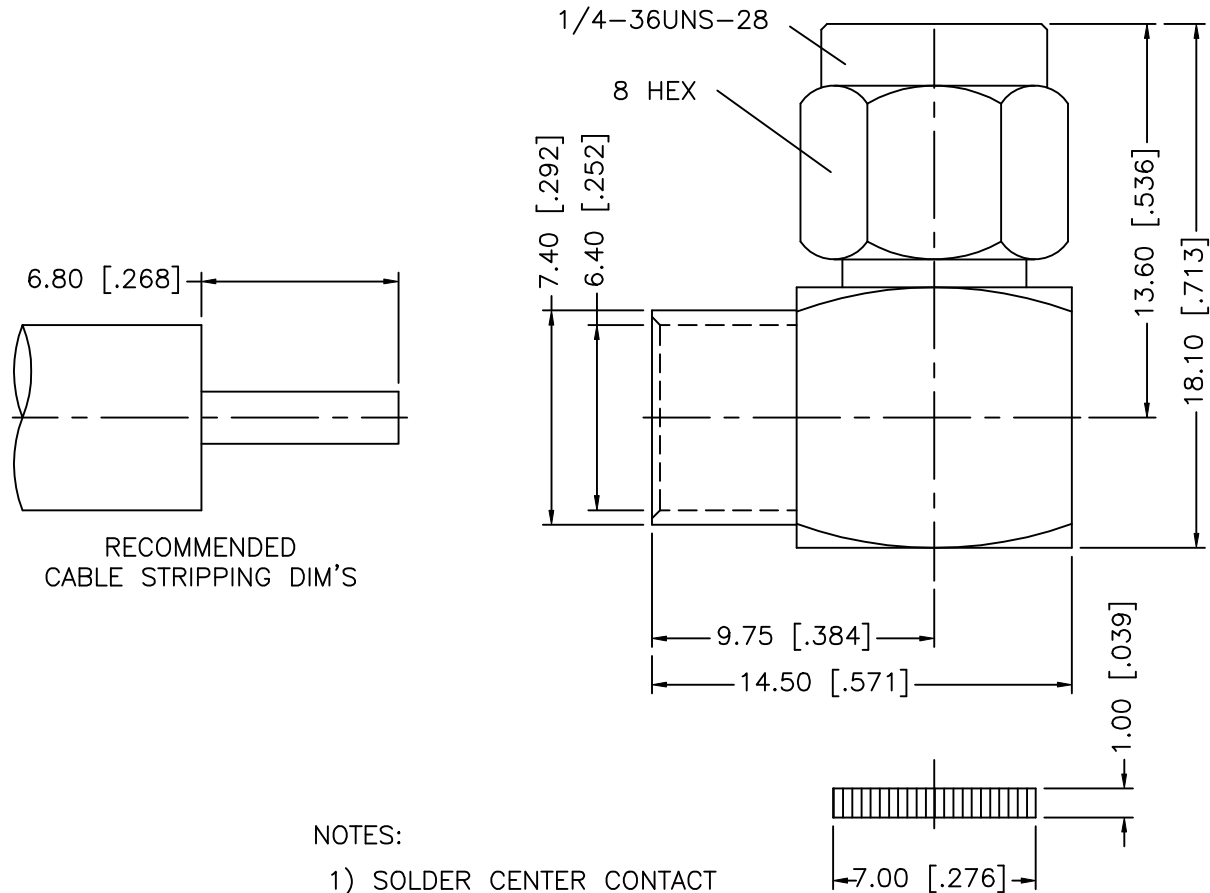

8			
7			
6			
5			
4	COVER	BRASS	GOLD
3	CONTACT PIN	BRASS	GOLD
2	INSULATOR	TEFLON	NATURAL
1	HOUSING/BODY	BRASS	GOLD
	DESCRIPTION	MATERIAL	FINISH

UNLESS OTHERWISE SPECIFIED  
DIMENSIONS ARE IN MILLIMETERS

DIMENSIONS IN [ ]  
ARE IN INCHES FOR  
CUSTOMER REFERENCE ONLY

UNLESS OTHERWISE SPECIFIED  
TOLERANCES FOR INCHES ARE:

.XXX = ± 0.005"  
.XX = ± 0.010"  
.X = ± 0.020"

DO NOT SCALE DRAWING

APPROVALS	DATE
DRAWN G.R.S.	06/11/02
CHECKED	
ISSUED	

**Amphenol - Connex**  
CONNECTOR CORPORATION

TITLE: SMA R/A DIRECT SOLDER PLUG  
(FOR .250" SEMI RIGID CABLE)

SIZE A	FSCM NO. 99001	DWG. NO. 132344.DWG	REV. NC
SCALE NA	PART NO. 132344	SHEET 1 OF 1	