

REVISIONS			
REV	DESCRIPTION, ECN, EAR NO.	DATE	APP'D
D	PRODUCT DRAWING (EAR 14166)	APR15/13	K.L.
E	PRODUCT DRAWING (EAR 14296)	JUL24/14	K.L.

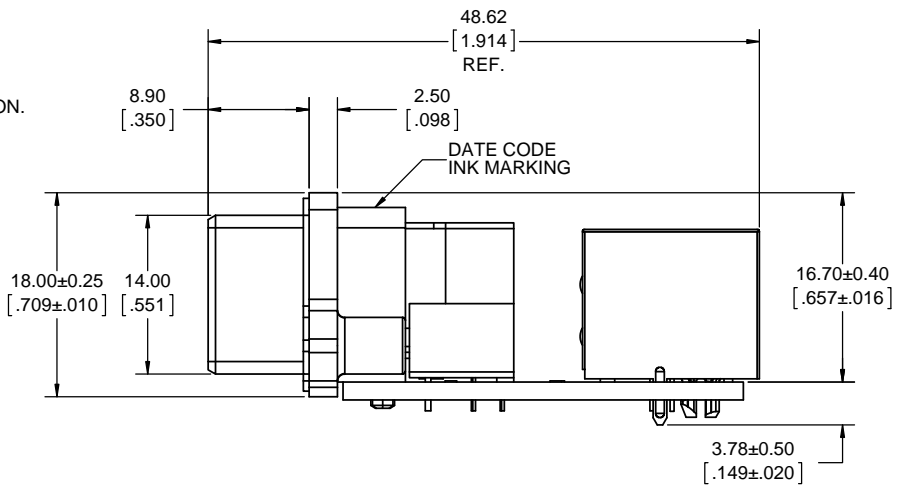
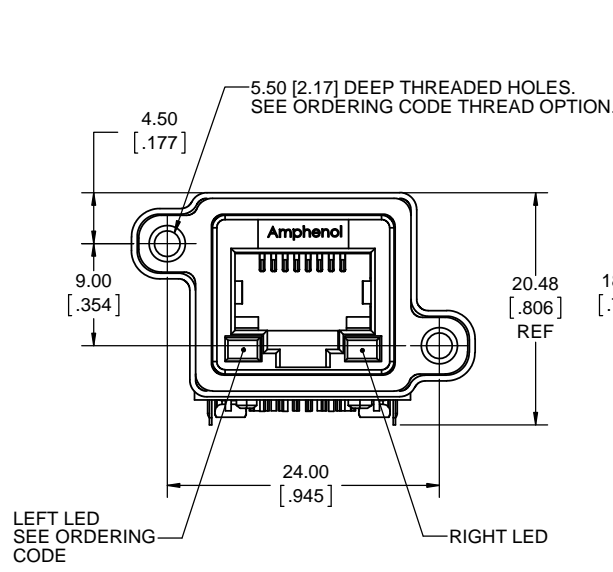

**ORDERING CODE: MRJ-578X-X1**

SERIES, RUGGED RJ  
 RECEPTACLE, 8 CONTACTS  
 RIGHT ANGLE, ON PCB  
 WITH STANDARD RJ RECEPTACLE  
 LED OPTION:  
 0 = NONE  
 1 = LEFT GREEN, RIGHT YELLOW  
 4 = LEFT YELLOW, RIGHT GREEN  
 5 = LEFT GREEN, RIGHT GREEN  
 MOUNTING HOLE THREAD OPTION:  
 0 = #4-40 UNC THREAD  
 M = M3 X 0.5 THREAD  
 SINGLE PORT

**SPECIAL CONNECTORS**  
 MANY UNIQUE FEATURES ARE READILY AVAILABLE TO SUIT CUSTOMER REQUIREMENTS. CONSULT WITH AMPHENOL CANADA FOR DETAILS.

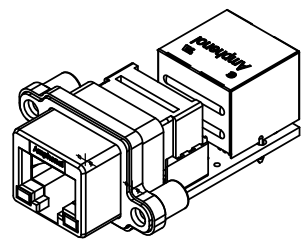
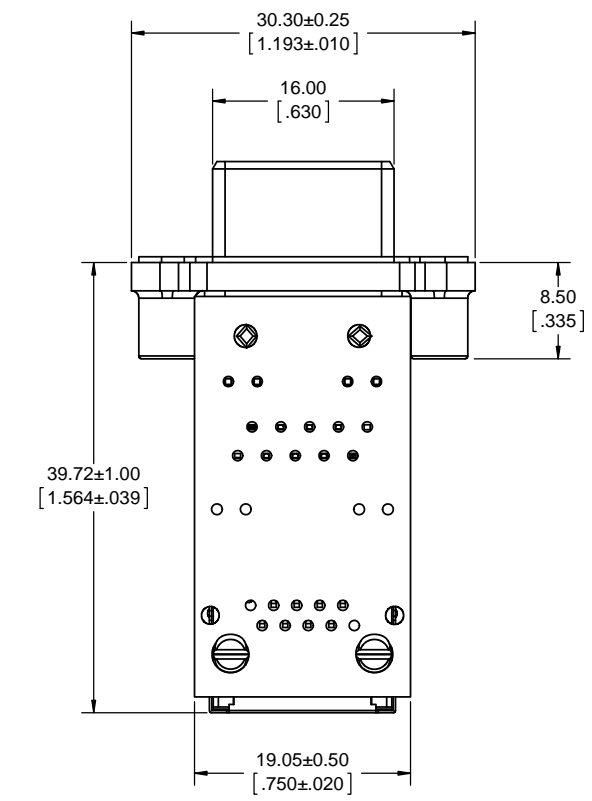

**NOTES:**

- MATERIAL:**  
 ALL MATERIALS ARE RoHS COMPLIANT PER EU DIRECTIVE 2011/65/EU AND AMENDMENTS
  - SHELL - DIECAST ZINC ALLOY, NICKEL PLATED
  - CONTACTS - PHOSPHOR BRONZE WITH 1.27 μm [50 μm] GOLD OVER 1.27 μm [50 μm] MINIMUM NICKEL ON THE MATING AREA AND MATTE TIN OVER NICKEL ON THE CONTACT TAILS.
  - INSERTS - ENGINEERING THERMOPLASTIC, FLAMMABILITY RATING UL94V-0
  - REAR INSERTS: BLACK NYLON, FRONT INSERT: CLEAR POLYCARBONATE
  - LED'S - EPOXY LENS, STEEL TAILS WITH TIN PLATING
  - GASKET - SILICONE RUBBER
  - PCB - FR-4 FIBERGLASS, LEAD FREE
  - STANDARD RJ RECEPTACLE - AMPHENOL P/N RJHSE-5F80, PHOSPHOR BRONZE CONTACTS WITH 1.27 μm [50μm] GOLD OVER NICKEL ON MATING AREA, BLACK NYLON INSERT AND COPPER ALLOY SHIELD WITH NICKEL PLATING
- ENVIRONMENTAL PERFORMANCE PER IEC 60529 CODE IP67 FOR SEAL BETWEEN MATING AREA AND PCB SIDE OF CONNECTOR. GASKET PROVIDES SEAL TO INSIDE FACE OF PANEL.
- CURRENT RATING: 1.5 AMPERES.
- CONTACT RESISTANCE: 80 MILLIOHMS MAXIMUM (SUBJECT TO VERIFICATION).
- OPERATING TEMPERATURE: -40°C TO +105°C.
- LED CHARACTERISTICS: FORWARD DC CURRENT 25 mA MAX, FORWARD VOLTAGE 2.5 V MAX @ 2 mA.
- AVAILABLE MATING AREA COVERS PROVIDE ADDED PROTECTION. CONSULT WITH AMPHENOL CANADA FOR DETAILS.
- RECOMMENDED TORQUE FOR PANEL MOUNT SCREWS: 0.45 TO 0.65 Nm [4.0 TO 5.75 IN-LBS] FOR STEEL SCREWS WITH 3.00 [118] MINIMUM THREAD ENGAGEMENT.
- CUSTOMER TO VERIFY THAT ALL PROCESS CLEANERS ARE COMPATIBLE WITH POLYCARBONATE MATERIAL.



UNLESS SPECIFIED OTHERWISE	DRAWN	S.SEMENOV	JAN01/07
PRIMARY UNITS MILLIMETERS	CHECKED		
SECONDARY INCHES	M.E. APP'D		
REFERENCE IN PARENTHESES	Q.A. APP'D		
GENERAL TOLERANCES	DWG APPR.	A.GREEN	JAN01/07
1 DECIMAL PLACE	ENG. REL. NO.		
2 DECIMAL PLACES ±0.15	REF.		
3 DECIMAL PLACES	THIRD ANGLE PROJECTION		
ANGULAR DEGREES	DO NOT SCALE DRAWING		

**Amphenol Canada Corp.**  
 www.amphenolcanada.com  
**MRJ SERIES RUGGED MODULAR JACK,**  
**8 POSITION, RIGHT ANGLE, ON PCB,**  
**WITH STANDARD RJ RECEPTACLE,**  
**RoHS COMPLIANT**

DWG. NO. **P-MRJ-578X-X1** REV **E**

CODE ID NO. 03554 DWG SIZE: X SCALE: 3:1 SHEET 1 OF 2

MRJ CONTACT 1 MRJ CONTACT 8

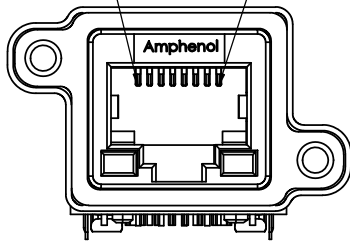

MRJ TO RJ CONNECTIONS	
MRJ	RJ
1	1
2	2
3	3
4	4
5	5
6	6
7	7
8	8
SHELL/GROUND	SHIELD/GROUND
PCB HOLES	
LED 1	1
LED 2	2
LED 3	3
LED 4	4

REVISIONS			
REV	DESCRIPTION, ECN, EAR NO.	DATE	APP'D
D	PRODUCT DRAWING (EAR 14166)	APR15/13	K.L.
E	PRODUCT DRAWING (EAR 14296)	JUL24/14	K.L.

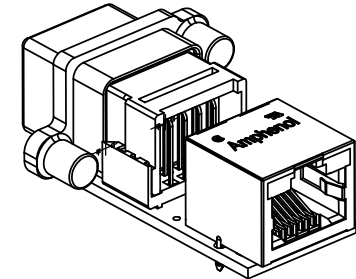
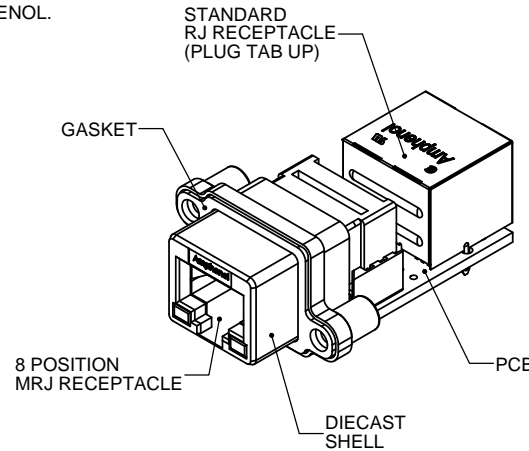
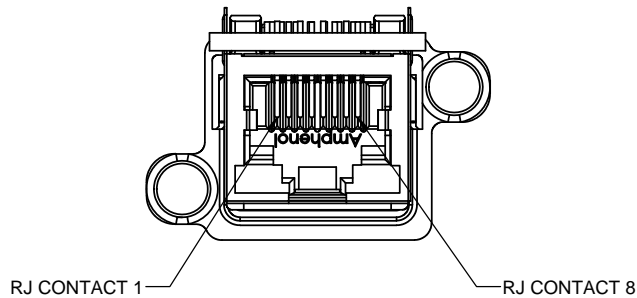
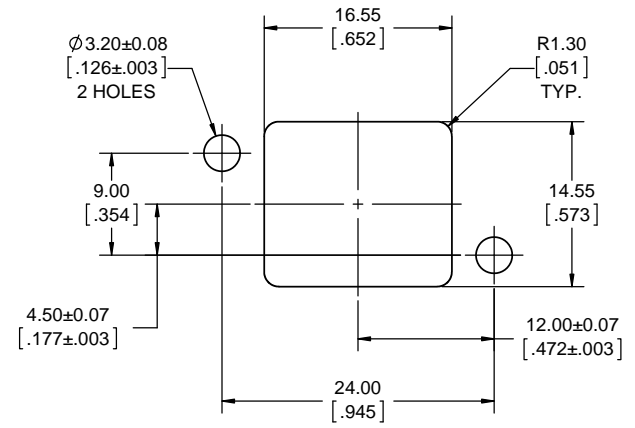
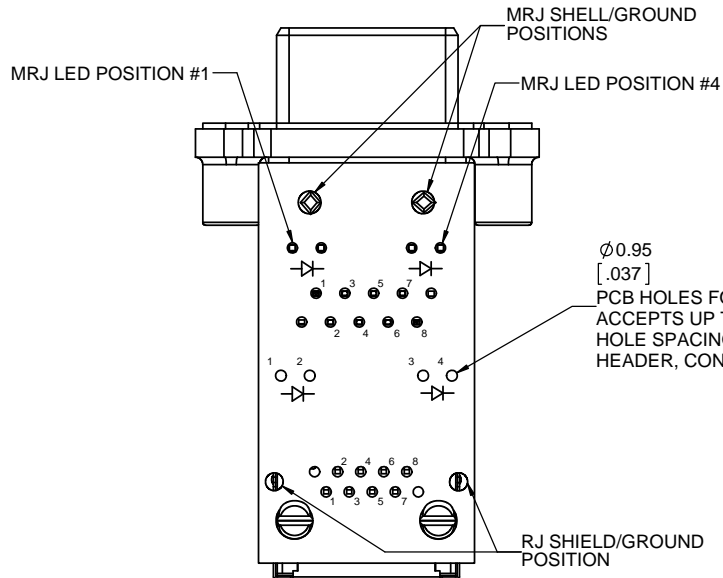

UNLESS SPECIFIED OTHERWISE	DRAWN	S.SEMENOV	JAN01/07
PRIMARY UNITS MILLIMETERS	CHECKED		
SECONDARY UNITS INCHES	M.E. APP'D		
REFERENCE IN PARENTHESES	Q.A. APP'D		
GENERAL TOLERANCES	DWG APPR.	A.GREEN	JAN01/07
1 DECIMAL PLACE	ENG. REL. NO.		
2 DECIMAL PLACES ±0.15	REF.		
3 DECIMAL PLACES	THIRD ANGLE PROJECTION		
ANGULAR DEGREES	DO NOT SCALE DRAWING		

**Amphenol Canada Corp.**  
www.amphenolcanada.com

**MRJ SERIES RUGGED MODULAR JACK, 8 POSITION, RIGHT ANGLE, ON PCB, WITH STANDARD RJ RECEPTACLE, RoHS COMPLIANT**

DWG. NO. **P-MRJ-578X-X1** REV **E**

CODE ID NO. 03554 DWG SIZE: X SCALE: 3:1 SHEET 2 OF 2