

TJG112711

REV	ECN	APP'D
-	6321	JT 2/5/09

INDEXING INDICATOR

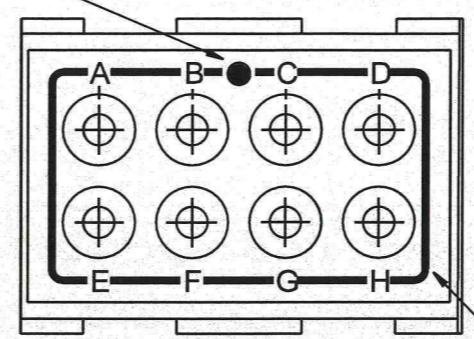

MARKING COLOR: WHITE

SEALING GROMMET

HOUSING

NOTES:

- MODULE MEETS ALL REQUIREMENTS OF SAE-AS81714/27, CLASS D, EXCEPT AS SHOWN.
- MODULE ASSEMBLY CONSTRUCTION:
 - A. HOUSING - POLYETHERIMIDE, COLOR: BLACK.
 - B. SEALING GROMMET - SILICONE PER A-A-59588, COLOR: BLUE.
 - C. INTERNAL SOCKET CONTACTS - COPPER ALLOY, GOLD PLATED PER MIL-G-45204, TYPE I, GRADE C, CLASS 1.
 - D. STUD - COPPER ALLOY, GOLD PLATED.
- MODULE MARKING AND IDENTIFICATION IS FLUSH WITH SURFACES, COLOR: WHITE.
- RECOMMENDED EXTERNAL PIN CONTACT SERVICE TOOLS -
 - A. CRIMP TOOL #M22520/1-101 WITH POSITIONER #M22520/1-02.
 - B. INSTALLING/REMOVAL TOOL #M81969/14-04, APCD #CNA078003.
- MODULE ACCEPTS -
 - A. MATING PIN CONTACTS #M39029/1-103, APCD #CNP072000
 - B. SEALING PLUGS #MS27488-12, APCD #CNA032403
- (9) PIN CONTACTS AND SEALING PLUGS SUPPLIED WITH EACH MODULE.
- MOUNTING HARDWARE SUPPLIED WITH EACH MODULE -
 - (2) FLAT WASHERS PER AN-960-C-10L
 - (1) LOCK WASHER PER MS35338-138
 - (1) NUT PER MS35650-304

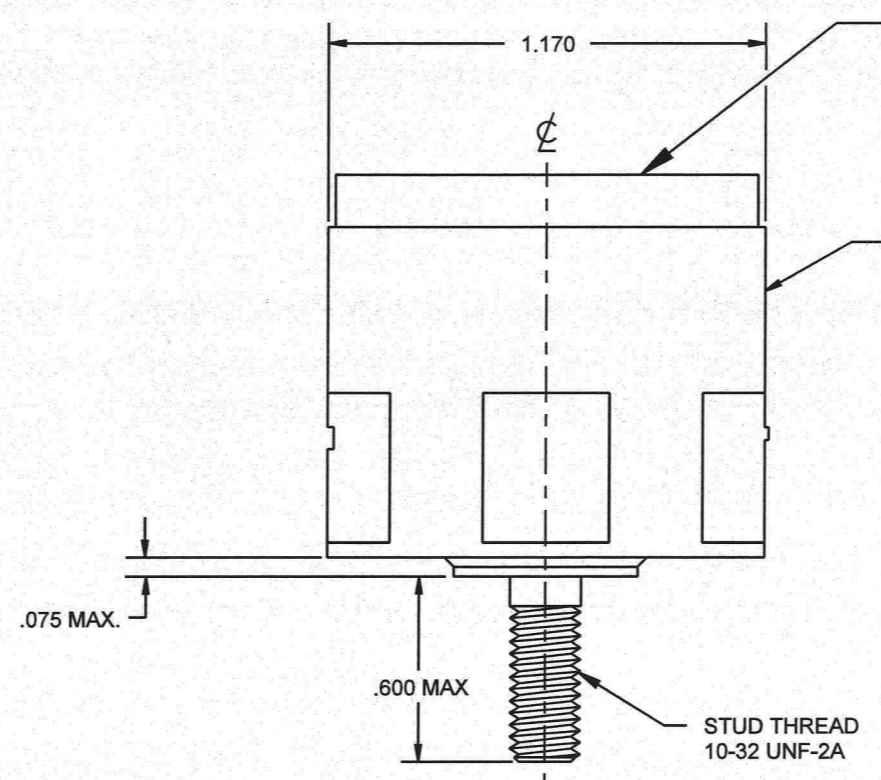
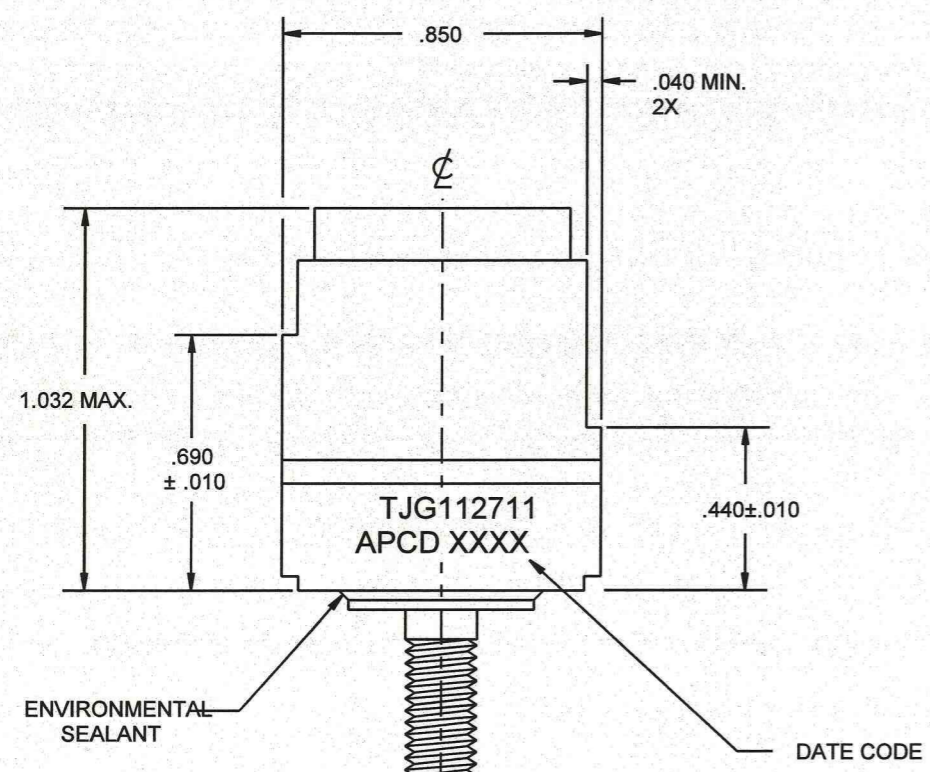

TJG112711

TJG112711

DIMENSIONS ANSI Y14.5M UNITS: INCHES Pro/E FILE	TOLERANCES .XX ± 0.01 .XXX ± 0.005 ANGLES ± 2.0°	PROJECTION 	Amphenol Pcd SPECIFICATION DRAWING		TITLE TERMINAL JUNCTION GROUNDING MODULE, SIZE 12, CLASS D STAINLESS STEEL HARDWARE		
			ENGR M. DiGIACOMO 1/26/09	CHKD <i>[Signature]</i> 2/5/09	APPD <i>[Signature]</i> 2/5/09	SIZE B	DWG NO. TJG112711
ORIGINAL 	THIS DOCUMENT CONTAINS PROPRIETARY INFORMATION WHICH IS THE CONFIDENTIAL PROPERTY OF AMPHENOL PCD INC., BEVERLY, MA			CODE: 58982	SCALE: 2.000	SHEET 1 OF 1	