

REVISIONS				
SYM	ZONE	ECN, ERN NO.	DATE	APPRD.
A		PROPOSAL	MAR18/13	L.CHAN

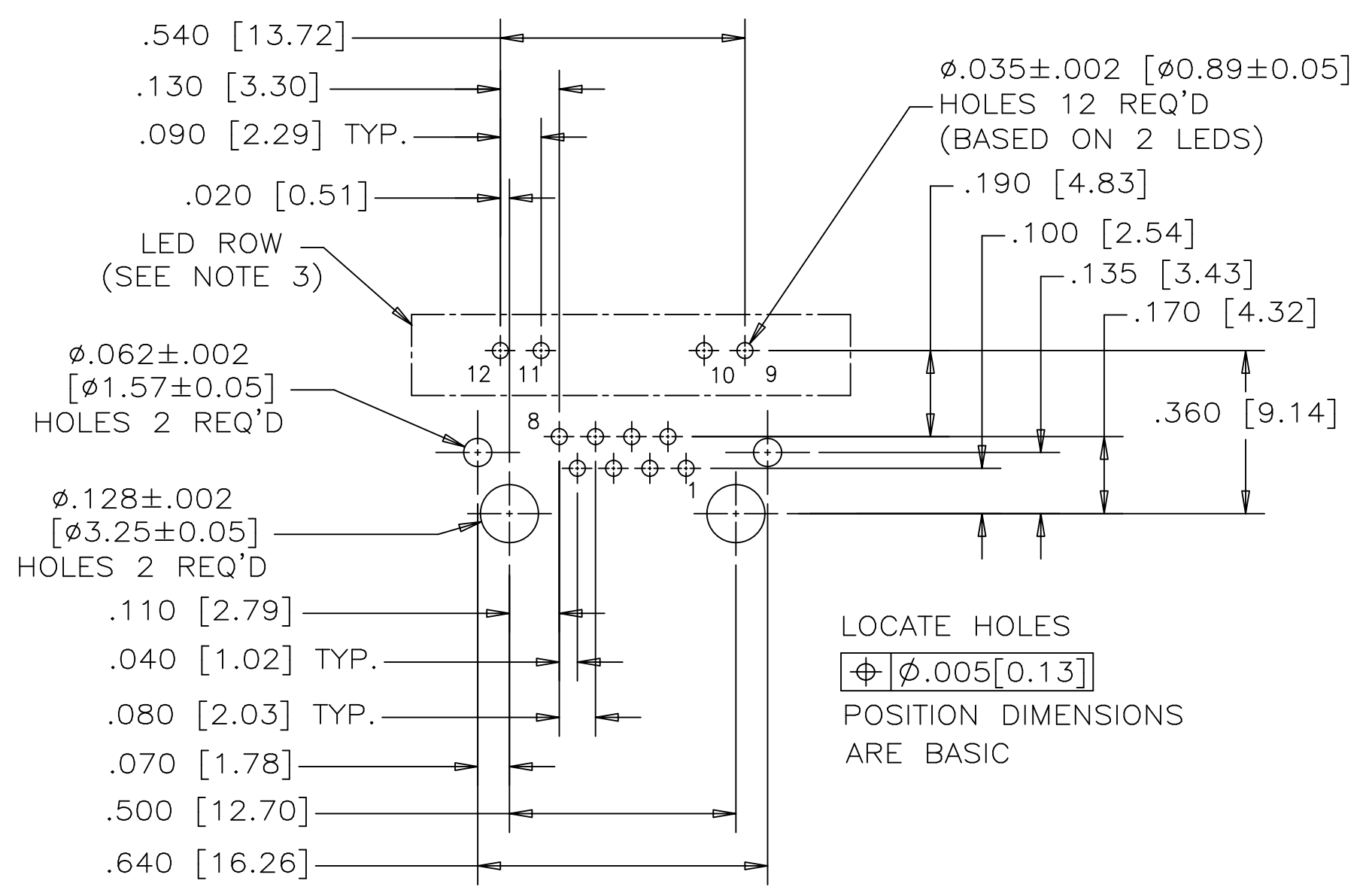

RECOMMENDED P.C.B. LAYOUT
(COMPONENT SIDE OF BOARD)

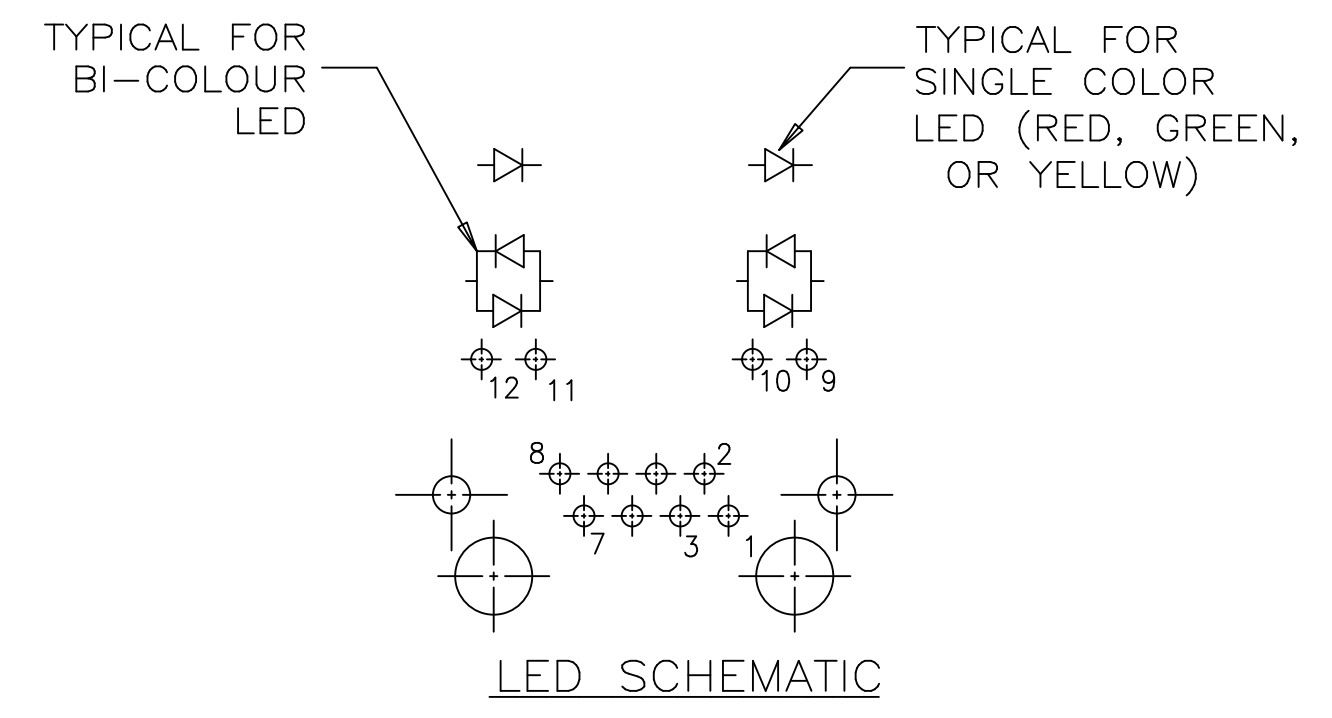
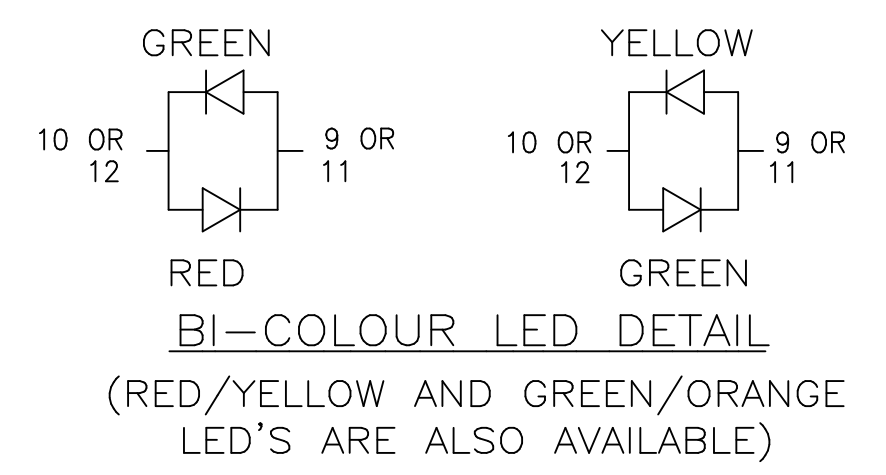
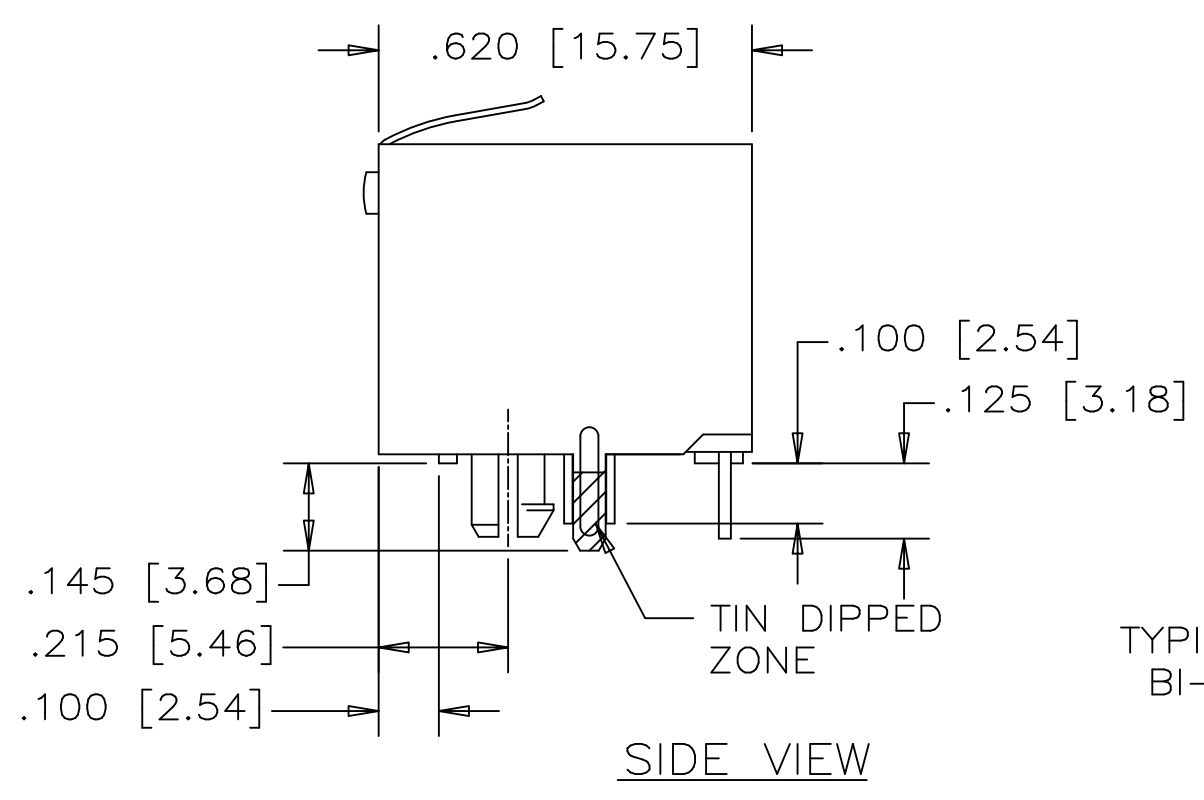
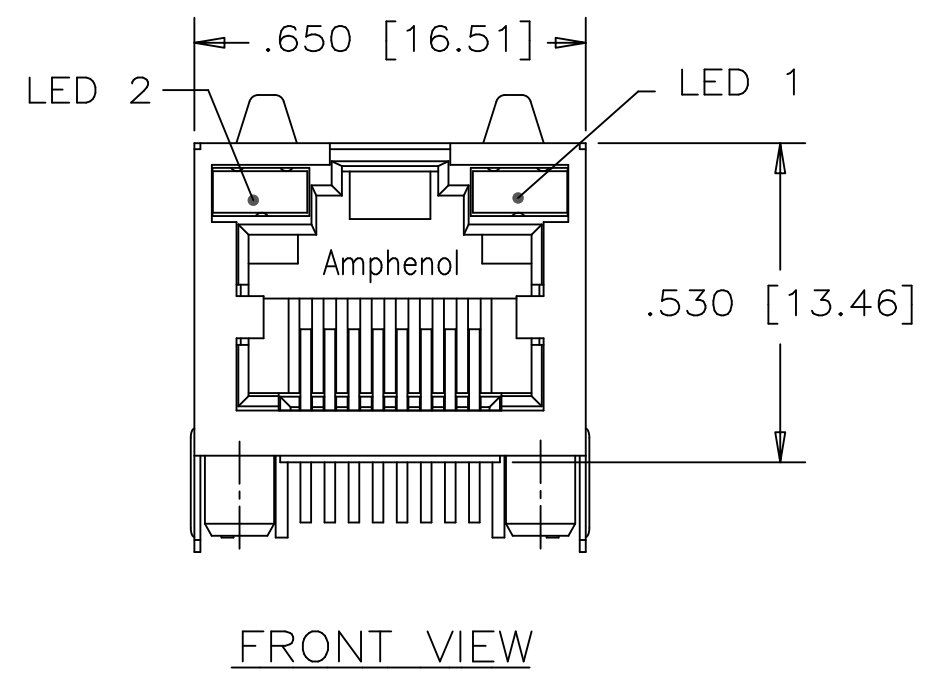
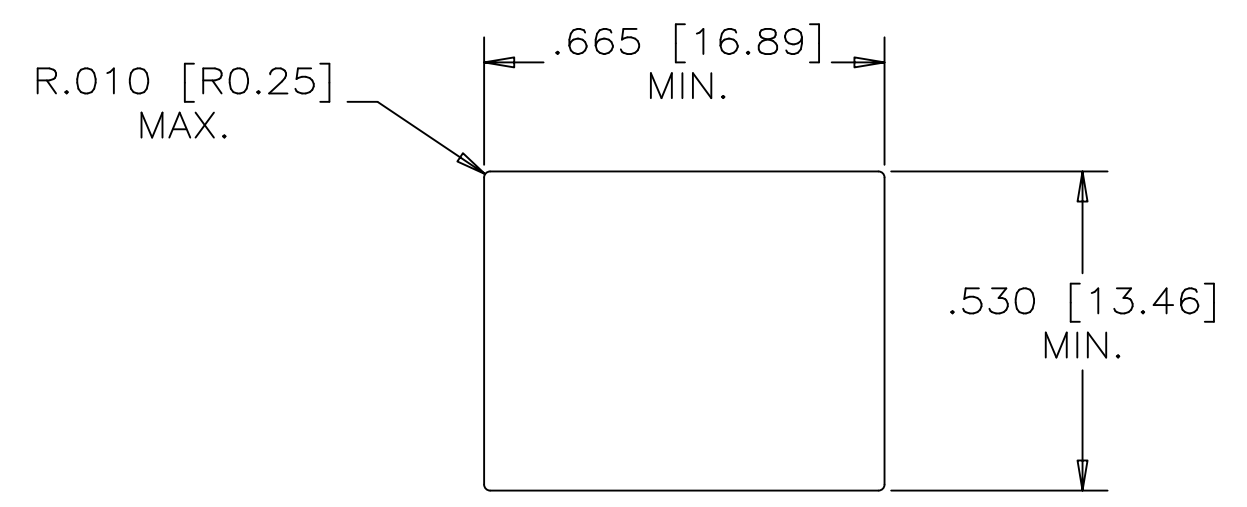

RECOMMENDED PANEL CUTOUT

NOTES:

- MATERIALS:**
 PLASTIC HOUSING: HIGH TEMPERATURE THERMOPLASTIC
 FLAMMABILITY RATING UL 94V-0, COLOUR: BLACK

 CONTACTS: PHOSPHOR BRONZE
 PLATING: 15 μ" [0.38 MICRONS]
 MIN. GOLD ON MATING SURFACES.
 50 μ" [1.27 MICRONS]
 MIN. NICKEL UNDERPLATE
 100 μ" [2.54 MICRONS]
 MIN. MATTE TIN ON CONTACT TAILS.

 SHIELD: STAINLESS STEEL WITH TIN DIP ON SOLDER TAIL
- RECOMMENDED SOLDERING TEMPERATURE:**
 WAVE SOLDERING AT 260°C MAXIMUM FOR 5 SEC MAXIMUM.
- P.C.B HOLE LAYOUT:**
 AMPHENOL PART NUMBER RJHSE-G38X P.C.B LAYOUT LED HOLES ARE OPTIONAL.
- PART NUMBER:** RJHSE-G38X
 REFER TO LED OPTIONS DRAWING FOR ORDERING CODES



THIS DOCUMENT CONTAINS PROPRIETARY INFORMATION AND SUCH INFORMATION MAY NOT BE DISCLOSED TO OTHERS FOR ANY PURPOSE OR USED FOR MANUFACTURING PURPOSES WITHOUT WRITTEN PERMISSION FROM AMPHENOL CANADA CORP.

DRAWN	AMY.Z	DATE	MAR18/13	Amphenol Canada Corp.	
DESIGNED					
CHECKED	L.CHAN	DATE	MAR18/13		
I. E. APPRD.					
Q. A. APPRD.				TITLE	HIGH SPEED, RJ45, MODULAR JACK, 8 POSITION, 8 CONTACTS, SHIELDED WITH LEDs OPTIONS - RoHS COMPLIANT
DWG. APPRD.				DWG	DRAWING NO.
ENG. REL. NO.					P-RJHSE-G38X
REF.				REV.	A
DIMENSIONS ARE IN INCHES [mm]	CODE ID. NO.	03554	SCALE	WT.	SURF.
					SHEET 1 OF 1