

FORWARD REGULATOR (Multi-Pellet) DIODES

These high speed multi-pellet diodes are used in computer circuits and general purpose applications. They consist of one, two, three, or four silicon diode chips in series, mounted in a DO-35 hermetically sealed glass package. This structure makes possible devices having controlled conductance and low leakage. This controlled conductance is necessary for the design of clippers, dc coupling circuits, clamping circuits, meter protectors, bias regulators, and other types of circuits that require tight tolerance on low voltage levels.

ELECTRICAL CHARACTERISTICS @ 25°C unless otherwise stated

Part Number	Minimum Breakdown Voltage, BVR at 5uA, Volts	Forward Voltage	Maximum Reverse Current			Maximum Capacitance* at 0 Volts f = 1 MHz, pF	Stored Charge	
			at 25°C nA	at 150°C uA	at Volts		Min pC	Max pC
1N4156	30	Table 1	50	50	20	25	50	500
1N4157	30	Table 2	50	50	20	20	50	500
1N4453	30	Table 3	50	50	20	30	50	500
1N5179	30	Table 4	50	50	20	20	50	500
1N4829	30 at 100 uA	Table 5	100	25 at 100°C	20	25	-	-
1N4830	30 at 100 uA	Table 6	100	25 at 100°C	20	20	-	-

MPD MULTI

C6344	90	Table 9	30	30	7 (typ.)	60	300
MPD200	30	Table 7	30	20	20	75	400
MPD300	60	Table 8	30	20	15	75	400
MPD400	90	Table 9	30	20	10	60	300

I _c	Forward Voltage, V _f , Volts								
	Table 1	Table 2	Table 3	Table 4	Table 5	Table 6	Table 7	Table 8	Table 9
mA	Min-Max	Min-Max	Min-Max	Min-Max	Min-Max	Min-Max	Min-Max	Min-Max	Min-Max
0.010	0.74-1.09	1.19-1.54	.430-.550	1.40-2.10			0.90-1.00	1.40-1.54	1.82-2.01
0.100	0.97-1.22	1.52-1.77	.510-.630	1.80-2.50	0.84-1.25	1.35-1.80	1.05-1.16	1.62-1.78	2.14-2.36
1.0	1.21-1.41	1.85-2.05	.600-.710	2.20-2.80	0.99-1.44	1.63-2.08	1.22-1.34	1.84-2.03	2.47-2.71
10	1.38-1.58	2.12-2.32	.690-.800	2.60-3.20	1.16-1.61	1.90-2.35	1.39-1.54	2.10-2.33	2.80-3.07
100 **	1.54-1.84	2.36-2.66	.800-.920	3.00-3.70	1.35-1.87	2.15-2.69	1.60-1.76	2.40-2.65	3.16-3.49

* Capacitance as measured on Boonton 75A Capacitance Bridge at a signal level of 50 mA rms and a frequency of 1 MHz
** Pulsed measurement. Pulse width = 300 nsec, Duty cycle <= 2%

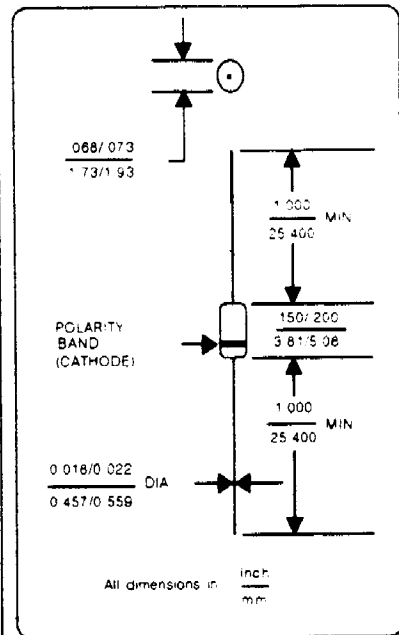

FIGURE 1

DESIGN DATA

CASE: Hermetically sealed, glass case DO-35 Outline

LEAD MATERIAL: Copper clad steel

LEAD FINISH: Tin/Lead

POLARITY: Diode to be operated with the banded (cathode) end positive with respect to the opposite end

WEIGHT: 0.2 Grams

MOUNTING POSITION: Any

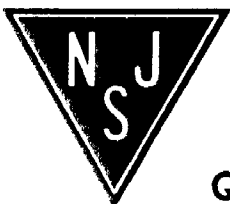

NJ Semi-Conductors reserves the right to change test conditions, parameter limits and package dimensions without notice. Information furnished by NJ Semi-Conductors is believed to be both accurate and reliable at the time of going to press. However, NJ Semi-Conductors assumes no responsibility for any errors or omissions discovered in its use. NJ Semi-Conductors encourages customers to verify that datasheets are current before placing orders.

Quality Semi-Conductors