



CE
0102



Model Number

14-14361

Features

- Up to 5000 ppr
- ATEX approval
- Flameproof enclosure
- 10 V ... 30 V with short-circuit proof push-pull output

Description

Incremental rotary encoders of the series 14 have been specially developed for use in areas with a high level of mechanical demand.

The shaft is specially equipped with a feather key groove for receiving a belt pulley wheel. The permissible radial force is 80 N and the permissible axial force is 60 N.

One special feature is the mechanical versatility of the flange. The incremental rotary encoder has a centering collar with a diameter of 40 mm and one with a diameter of 80 mm. Three M6 holes are available for fastening.

The pulse disk is designed in plastic for up to 1500 pulses. Beyond that, glass is used.

Technical data

General specifications

Detection type	photoelectric sampling
Pulse count	max. 5000

Electrical specifications

Operating voltage U_B	10 ... 30 V DC
No-load supply current I_0	max. 80 mA

Interface

Resolution	
Overall resolution	

Output

Output type	push-pull, incremental
Voltage drop U_d	< 4 V
Load current	max. per channel 40 mA, short-circuit protected, reverse polarity protected
Output frequency	max. 100 kHz
Rise time	250 ns
De-energized delay t_{off}	250 ns

Connection

Cable	Ø11.2 mm, 9-core, 2 m
-------	-----------------------

Standard conformity

Degree of protection	DIN EN 60529, IP66
Emitted interference	EN 61000-6-4:2007/A1:2011
Noise immunity	EN 61000-6-2:2005

Ambient conditions

Operating temperature	
Gas Ex-area	-40 ... 55 °C (-40 ... 131 °F)
Dust Ex-area	-30 ... 55 °C (-22 ... 131 °F)
Storage temperature	
Gas Ex-area	-40 ... 70 °C (-40 ... 158 °F)
Dust Ex-area	-30 ... 70 °C (-22 ... 158 °F)

Mechanical specifications

Material	
Housing	3.1645 aluminum
Flange	3.1645 aluminum
Shaft	Stainless steel 1.4305 / AISI 303
Mass	approx. 3000 g
Rotational speed	max. 6000 min ⁻¹
Moment of inertia	400 gcm ²
Starting torque	< 5 Ncm
Shaft load	
Axial	60 N
Radial	80 N

Data for application in connection with Ex-areas

EC-Type Examination Certificate	ZELM 02 ATEX 0078 X
Group, category, type of protection	⊕ II 2G Ex db IIC T6 Gb
	⊕ II 2D Ex tb IIIC T80°C Db IP66

Directive conformity	
Directive 94/9/EC	EN 60079-0:2012 EN 60079-1:2007 EN 60079-31:2009

Dimensions

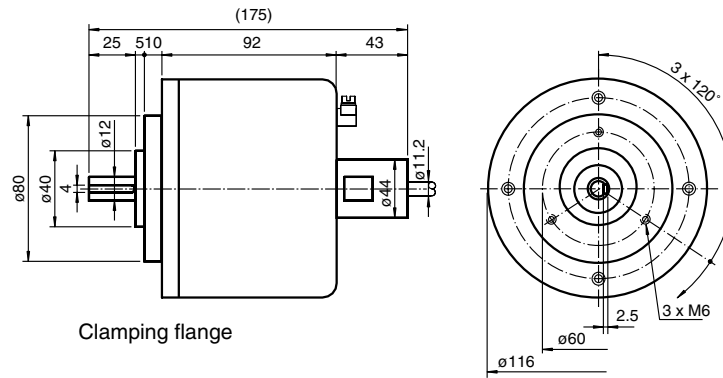

Electrical connection

Signal	Cable Ø11.2 mm, 9-core
GND	1
+U _b	2
A	3
B	4
\bar{A}	5
\bar{B}	6
0	7
$\bar{0}$	8
PE	Green/Yellow

Release date: 2014-12-11 09:20 Date of issue: 2014-12-11 12442_eng.xml

Signal outputs

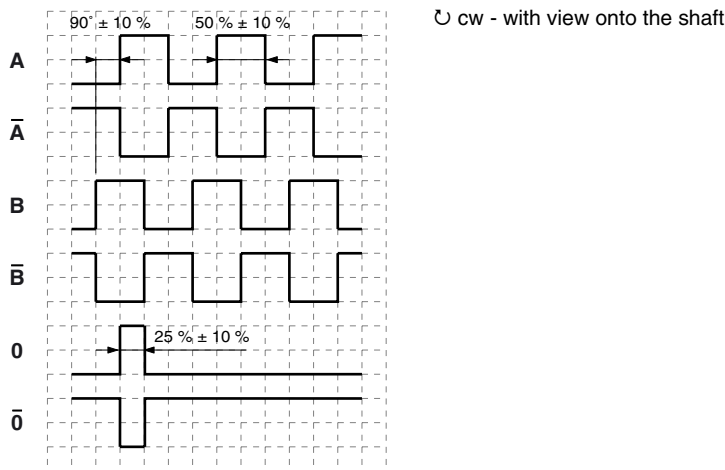

Order code

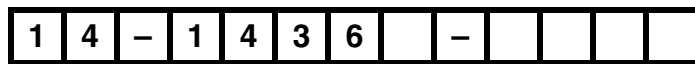

Pulse count

60, 100, 120, 180, 200, 250, 256, 300, 314, 360, 400, 500, 512, 600, 720, 900, 1000, 1024, 1200, 1250, 1500, 1800, 2000, 2048, 2400, 2500, 3000, 3600, 4000, 4096, 5000

Output switching

- 1 10 V ... 30 V, push-pull
- 6 5 V, RS 422
- X 10 V ... 30 V, RS 422

Signal output

36 $A + B + 0$ and $\bar{A} + \bar{B} + \bar{0}$