

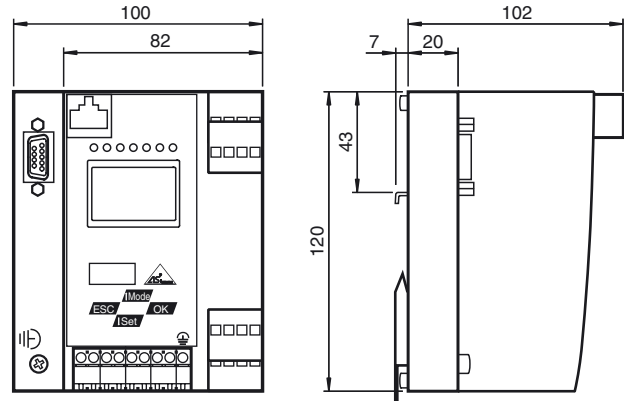

Dimensions

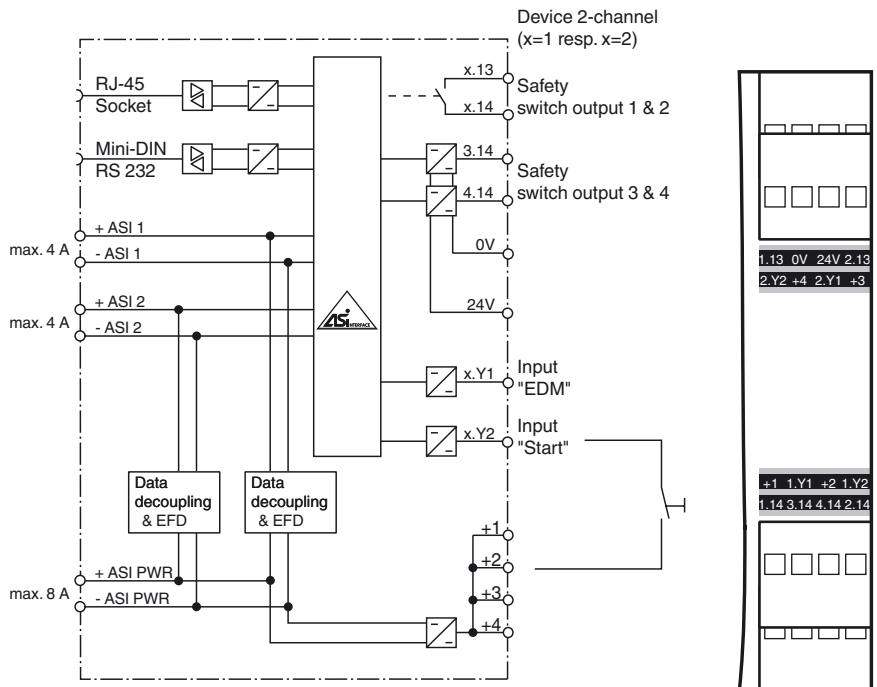

Electrical connection



Indicating / Operating means

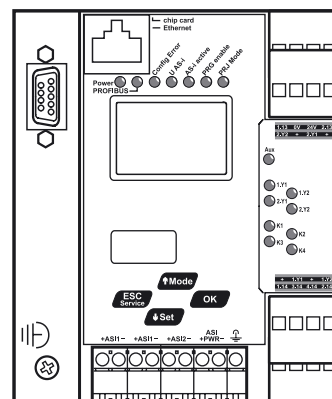

Model number

**VBG-PB-K30-DMD-S16-EV**

Gateway with integrated Safety Monitor

Features

- Gateway and safety monitor in one housing
- Connection to PROFIBUS DP
- SafeLink
- Certified up to SIL 3 according to IEC 61508 and EN 62061 and up to PL<sub>e</sub> according to EN 13849
- 2 AS-Interface networks
- 2 safe output relays and 2 safe electronic outputs
- Integrated data decoupling
- Diagnostics via RJ45 Ethernet port

Release date: 2013-03-07 09:38 Date of issue: 2014-01-13 245875\_eng.xml

Refer to "General Notes Relating to Pepperl+Fuchs Product Information".

Pepperl+Fuchs Group  
www.pepperl-fuchs.com

USA: +1 330 486 0001  
fa-info@us.pepperl-fuchs.com

Germany: +49 621 776 4411  
fa-info@de.pepperl-fuchs.com

Singapore: +65 6779 9091  
fa-info@sg.pepperl-fuchs.com

**Technical data****General specifications**

AS-Interface specification	V3.0
PLC-Functionality	activateable
Duplicate address detection	from AS-Interface slaves
Earth fault detection	EFD integrated
EMC monitoring	integrated
Diagnostics function	Extended function via display
Switch-on delay	< 10 s
Response delay	< 40 ms
UL File Number	E223772

**Functional safety related parameters**

Safety Integrity Level (SIL)	SIL 3
Performance level (PL)	PL e
MTTF <sub>d</sub>	200 a
B <sub>10d</sub>	2 E+7

**Indicators/operating means**

Display	Illuminated graphical LC display for addressing and error messages
LED PROFIBUS	PROFIBUS master detected; LED green
LED AS-i ACTIVE	AS-Interface operation normal; LED green
LED CONFIG ERR	configuration error; LED red
LED PRG ENABLE	autom. programming; LED green
LED POWER	voltage ON; LED green
LED PRJ MODE	projecting mode active; LED yellow
LED U AS-i	AS-Interface voltage; LED green
LED AUX	ext. auxiliary voltage U <sub>AUX</sub> ; LED green
LED EDM/Start	External device monitoring circuit inputs closed, 4x yellow LEDs
LED output circuit	Output circuit closed; 4 x green LEDs
Button	4

**Electrical specifications**

Insulation voltage	U <sub>i</sub>	≥ 500 V
Rated operating voltage	U <sub>e</sub>	26.5 ... 31.6 V from AS-Interface; Output K3 and K4 24 V DC
Rated operating current	I <sub>e</sub>	≤ 300 mA off AS interface network 1 ≤ 70 mA off AS interface network 2

**Interface 1**

Interface type	RS 485
Protocol	PROFIBUS DP V1
Transfer rate	9.6 kBit/s / 12 MBit/s , Automatic baud rate detection

**Interface 2**

Interface type	Ethernet: RJ-45 Diagnostic Interface
----------------	---

**Interface 3**

Interface type	Chip card slot
----------------	----------------

**Input**

Number/Type	4 EDM/Start inputs: EDM: Inputs for the external device monitoring circuits Start: start inputs: Static switching current 4 mA at 24 V, dynamic 30 mA at 24 V (T=100 μs)
-------------	---

**Output**

Safety output	Output circuits 1 and 2: 2 potential-free contacts, max. contact load: 3 A <sub>DC-13</sub> at 30 V <sub>DC</sub> , 3 A <sub>AC-15</sub> at 30 V <sub>AC</sub> Output circuits 3 and 4: 2 PNP transistor outputs max. contact load: 0.5 A <sub>DC-13</sub> at 30 V <sub>DC</sub>
---------------	---

**Connection**

PROFIBUS	Sub-D interface
AS-Interface	spring terminals, removable

**Ambient conditions**

Ambient temperature	0 ... 55 °C (32 ... 131 °F)
Storage temperature	-25 ... 85 °C (-13 ... 185 °F)

**Mechanical specifications**

Protection degree	IP20
Material	
Housing	Stainless steel
Mass	800 g
Construction type	Low profile housing , Stainless steel

**Compliance with standards and directives**

Directive conformity	
EMC Directive 2004/108/EC	EN 61000-6-2:2005, EN 61000-6-4:2007
Standard conformity	
Electromagnetic compatibility	EN 61000-6-2:2005, EN 61000-6-4:2007
AS-Interface	EN 50295:1999

**Function**

The VBG-PB-K30-DMD-S16-EV is a PROFIBUS gateway with a safety monitor and a double master according to AS-Interface specification 3.0.

The gateway is used to connect AS-Interface systems to a higher-level PROFIBUS. It acts as a master for the AS-Interface segment and as a slave for the PROFIBUS. During cyclic and acyclic data exchange, the AS-Interface functions are provided via PROFIBUS - DP V1. During cyclic data exchange the binary data of an AS-Interface segment is transferred. Analog values as well as the complete command set of the new AS-Interface specification are transferred via PROFIBUS using a command interface.

The gateway has four inputs and four outputs. The four inputs are used either for extended EDM device monitoring or as start inputs. Two sets of two outputs act as relay outputs and switch output circuits 1 and 2 and, as semiconductor outputs, output circuits 3 and 4. The K30 model is particularly suitable for installation in a control cabinet.

Configuration of the device can be performed using switches. Seven LED located on the front panel indicate the current status of the AS-Interface segment. One LED shows the power supply via AUX. A further eight LEDs indicate the status of the inputs and outputs. With the graphical display, the commissioning of the AS-Interface circuits and testing of the connected peripherals can take place completely separately from the commissioning of the higher-level network and the programming. With the 4 switches, all functions can be controlled and visualized on the display.

An RJ-45 Ethernet port provides a way of exporting data relating to the gateway, network and operation directly from the gateway for extended local diagnosis purposes.

Via the RJ-45 Ethernet diagnostic interface, up to 31 devices can establish a secure cross-communication.

The integrated data decoupling allows to operate 2 AS-Interface circuits with just a standard power supply.

The device has a card slot for a memory card for the storage of configuration data.

**Accessories****VAZ-SW-SIMON+**

Software for configuration of K30 Master Monitors/K31 and KE4 Safety Monitors

**USB-0,8M-PVC ABG-SUBD9**

Interface converter USB/RS 232

**VAZ-PB-DB9-W**

PROFIBUS Sub-D Connector with switchable terminal resistance

Protection degree	EN 60529:2000
Shock and impact resistance	EN 61131-2:2004
Fieldbus standard	PROFIBUS according to DIN 19245 Part 3
Standards	IEC 61508:2010 (SIL3) IEC 62061:2005 (SIL3) EN ISO 13849-1:2008 (PL e)

### Notes

In an AS-Interface network only one device can be operated earth fault detection. If there are many devices in an AS-Interface network, this can lead to the earth fault monitoring response threshold becoming less sensitive.