

### Model number

#### U-G1FA

AS-Interface module mounting base with addressing jack for connection to flat cable (AS-Interface)

### Function

The U-G1FA lower section makes it possible to connect slaves from the G1 and G4 series to the AS-Interface without an additional power supply (EMS). It features two connections to the AS-Interface which are linked together. In this way it can serve as a distributor from one AS-Interface arm to another. When an upper section (module or VAZ-DK-G1 cover) is mounted, the flat cables are pressed into the insulation penetration blades, thus creating a contact.

Furthermore, an addressing jack is also integrated; the upper section can be addressed in the wired AS-Interface network using this jack. In this case the controller registers "Alarm Config", as the slave is disconnected from the mains. Once the addressing jack has been removed, the controller restarts automatically again.

### Accessories

#### VAZ-DK-G1

Cover for bases -G1F- and -G1P-

### Dimensions

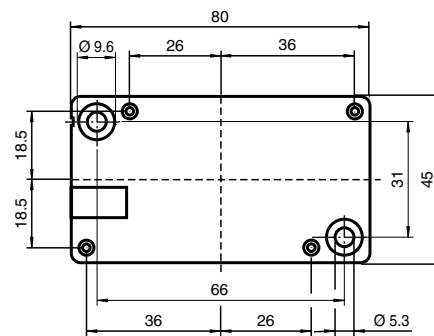

### Electrical connection

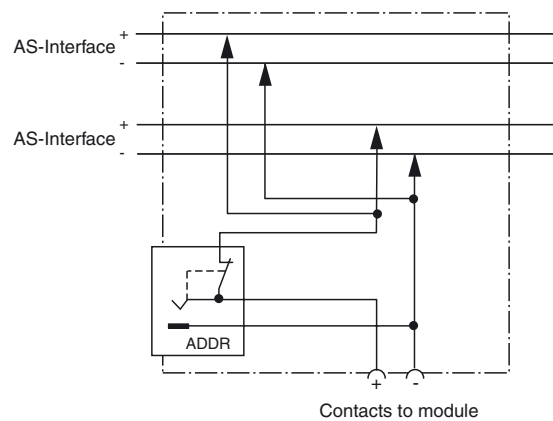

### Technical data

#### General specifications

UL File Number	E223772
----------------	---------

#### Electrical specifications

Current loading capacity	≤ 2 A for max. 40 V
--------------------------	---------------------

#### Ambient conditions

Ambient temperature	-25 ... 60 °C (-13 ... 140 °F)
Storage temperature	-25 ... 85 °C (-13 ... 185 °F)

#### Mechanical specifications

Protection degree	IP67 according to EN 60529 (only in connection with module or cover)
Connection	2 AS-Interface flat cables
Material	
Housing	PBT
Dimensions	about 80, 45, 20 mm (L, W, H)
Mounting	DIN rail or screw mounting

**Matching system components****VAA-2E-G4-SN**

G4 PG module IP67  
safety module with 2 inputs

**VBA-4E-G4-Pt100**

G4 module IP65  
4 inputs for Pt100

**VAA-4A-G1-R**

Standard module IP67  
4 relay outputs

**VAA-2EA-G1-ZE/P-S**

Pneumatic module  
2 inputs/2 pneumatic outputs

**VAA-4E2A-G1-ZE/P-S**

Pneumatic module  
4 inputs/2 pneumatic outputs

**VBA-4E2A-G1-ZE/P-S**

Pneumatic module  
4 inputs/2 pneumatic outputs

**VAA-2\*2E-G1-AE**

Standard module IP67  
2 x 2 inputs (PNP)

**VAA-4E-G4-Z**

G4 module IP67  
4 inputs (2-wire )

**VAA-4E-G1-ZE**

Standard module IP67  
4 inputs (PNP)

**VAA-LT2-G1**

Illuminated pushbutton module

**VBA-LT2-G1**

Illuminated pushbutton module

**VBA-LT2-G1-Y**

Illuminated pushbutton module

**VBA-4E-G4-ZE**

G4 module IP67  
4 inputs (PNP)

**VAA-4E-G4-ZE-IFM**

G4 module IP67  
4 inputs (PNP)

**VAA-4E-G4-ZE**

G4 module IP67  
4 inputs (PNP)

**VAA-4E-G4-N**

G4 module IP67  
4 inputs (NAMUR)

**VAA-4E-G4-ZE0**

G4 module IP67  
4 inputs (NPN)

**VAA-2EA-G1-ZE/P-V2A**

Pneumatic module  
2 inputs/2 pneumatic outputs