



Model Number

IC-KP-B7-V95

Control interface unit IDENTControl with interface for DeviceNet

Features

- Max. 4 read/write heads connectable
- Alternative 2 read/write heads and 2 trigger sensors can be connected
- LC display with background lightning
- Direct operation via 4 keys
- LED status indicator of bus communication and read/write heads

Dimensions

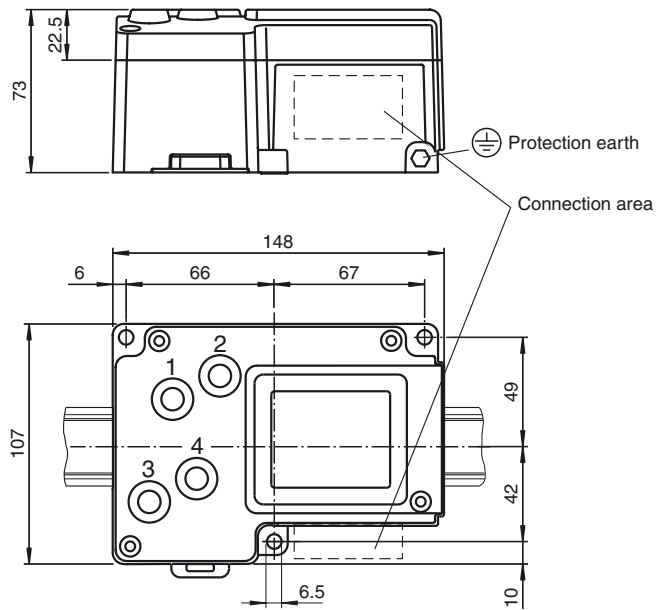

Electrical connection

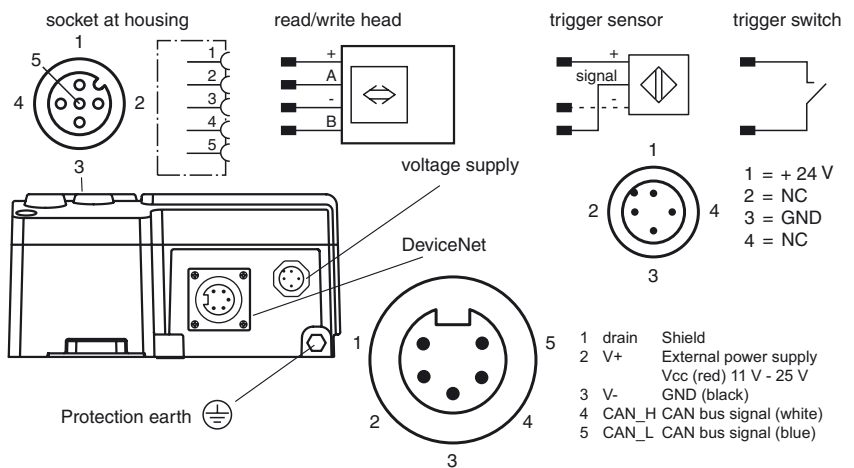

Indicating / Operating means

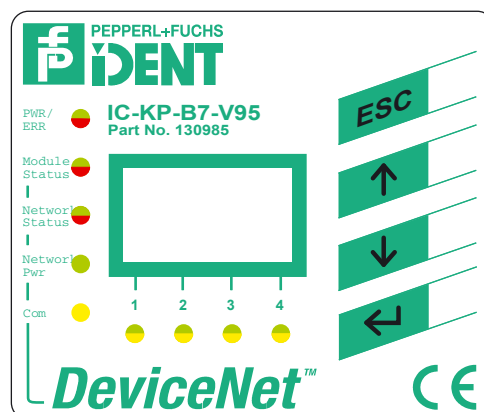

Release date: 2011-07-19 08:59 Date of issue: 2011-07-19 13:0985_eng.xml

Subject to modifications without notice

Pepperl+Fuchs Group
www.pepperl-fuchs.com

USA: +1 330 486 0001
fa-info@us.pepperl-fuchs.com

Germany: +49 621 776-4411
fa-info@pepperl-fuchs.com

Copyright Pepperl+Fuchs
Singapore: +65 6779 9091
fa-info@sg.pepperl-fuchs.com

Technical data**General specifications**

Number of read/write heads	max. 4 alternative 2 read/write heads and 2 trigger sensors
UL File Number	E87056

Indicators/operating means

LEDs 1, 2, 3, 4	Status indicator for read/write heads green: command at read/write head active yellow: approx. 1 second long, if command was successfully executed
LED PWR/ERR	green: power on red: Hardware fault
LED Module Status	green: normal operation red flashing: recoverable fault red: unrecoverable fault red/green flashing: LED test
LED Network Status	green: on-line, connected green flashing: on-line, not connected red: critical link failure red flashing: connection timeout red/green flashing: LED test
LED Network Pwr	green flashing at startup: LED test green: network power available
LED COM	yellow flashing at startup: LED test yellow: data exchange
LC display	two-line multi-function display with 12 characters per line configuration of the control interface and display of connected read/write heads as additional pictograms; easy and direct selection of operating commands and addressing
Button	4 keys: ESC, up, down and return

Electrical specifications

Rated operational voltage	U_e	20 ... 30 V DC, PELV
Ripple		≤ 10 % at 30 V DC
Current consumption		≤ 2 A incl. read/write heads
Power consumption	P_0	2.5 W Without read/write heads
Network voltage		11 ... 25 V DC, PELV
Network current consumption		≤ 40 mA
Electrical isolation		basic insulation acc. to DIN EN 50178, rated insulation voltage of 50 V _{eff}

Interface

Physical	DeviceNet
Protocol	CIP
Transfer rate	125, 250, 500 kBit/s

Ambient conditions

Ambient temperature	-25 ... 70 °C (-13 ... 158 °F)
Storage temperature	-30 ... 80 °C (-22 ... 176 °F)
Climatic conditions	air humidity max. 96 %
Shock and impact resistance	Oscillation (Sine): 5 g, 10 - 1000 Hz to EN 60068-2-6 Shock (Half-sine): 30 g, 11 ms in accordance with EN 60068-2-27

Mechanical specifications

Protection degree	IP67
Connection	Read/write heads: shielded, 4-pin, M12 connector Power supply: M12 connector Protective earth: M6 earthing screw DeviceNet: Mini-Style
Material	
Housing	powder coated aluminum
Installation	snap-on to 35 mm standard rail or screw fixing
Mass	approx. 1000 g

Compliance with standards and directives

Standard conformity	
Electromagnetic compatibility	EN 61326:2003
Protection degree	IEC 60529:2001

Function

The innovative concept of the RFID identification system **IDENTControl** from Pepperl+Fuchs has many advantages in comparison to other systems. The core piece of the system is the evaluation unit **IDENTControl**.

Thanks to the integrated interfaces for all standard field bus systems such as PROFIBUS, EtherNet, PROFINET IO, DeviceNet, serial connections (RS 232/RS 485/RS 422) and numerous connection options for inductive write/read heads as well as microwave antennas, the evaluation unit **IDENTControl** can be adjusted to your needs in a flexible and easy manner.

4 function keys and a double-spaced illuminated LC display facilitate easy system configuration, parameter assignment and entering commands. Further LEDs indicate operating power and bus communication, connected write/read heads and active write/read commands.

Mounting the unit onto DIN mounting rails is easy thanks to the snap-fits on the back of the housing of the evaluation unit **IDENTControl**.

With its L-shaped housing, the evaluation unit including bus connector fits into a 120 mm grid in the switch cabinet. The mounting depth of 70 mm furthermore enables installation in flat switch boxes with a depth of only 100 mm.

There are 3 further mounting holes for field mounting.

Accessories**DNV95-G-TERM**

Bus termination for DeviceNet

DNV95-G-0M-T-0M-V95-G-L

T-Distributor for DeviceNet

V1-G-5M-PUR-ABG-V1-W

Connecting cable, M12 to M12, PUR cable 4-pin, shielded

V1-G-5M-PUR

Cable socket, M12, 4-pin, PUR cable

DNV95-G-5M-PVC-V95-G

Connection cable, DeviceNet, 7/8" on 7/8", PVC cable