



Model Number

BT115X

Activator for F31 series

Features

- Suitable for right and left rotating drives
- Action reversed (end position undamped)

Dimensions

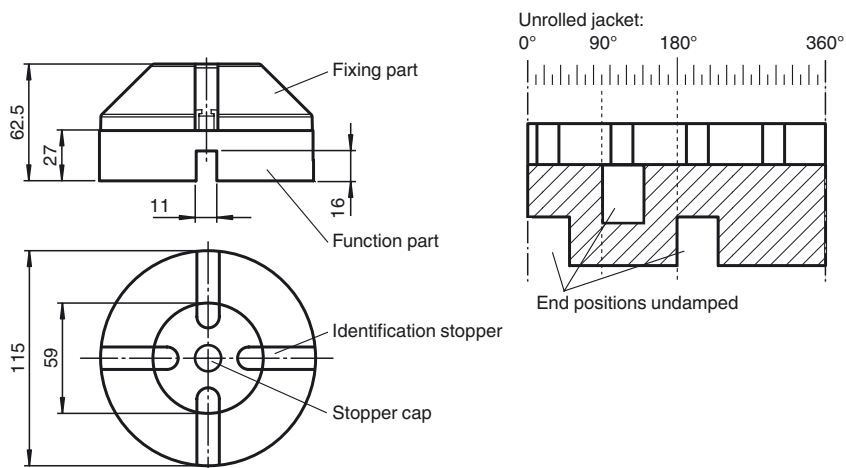

Technical data

General specifications

Ring diameter	≤ 110 mm
Spring ring height	≤ 7 mm

Ambient conditions

Ambient temperature	-25 ... 70 °C (-13 ... 158 °F)
---------------------	--------------------------------

Mechanical specifications

Shaft diameter	< 90 mm
Shaft height	30 mm and 50 mm
Mounting hole pattern	30 x 130 mm

Material

Housing	Mounting component: PA Function component: Stainless steel 1.4305 / AISI 303
Spacer disk	PA (2 units, 10 mm strong)
Stopper cap	PBT (1 unit black)
Identification stopper	PA (2 units yellow, 2 units black)
Mounting screw	for activator: 1.4305 / AISI 303 (1 unit M6 x 25) for sensors - F31: 1.4305 / AISI 303 (4 items M5 x 16, (2 pieces M5 x 12)
Mass	140 g

Note

The activator consists of stainless steel and a conductive plastic material which prevents static charging and allows installation in potentially explosive environments.

Release date: 2008-07-21 16:55 Date of issue: 2014-12-25 195287_eng.xml