

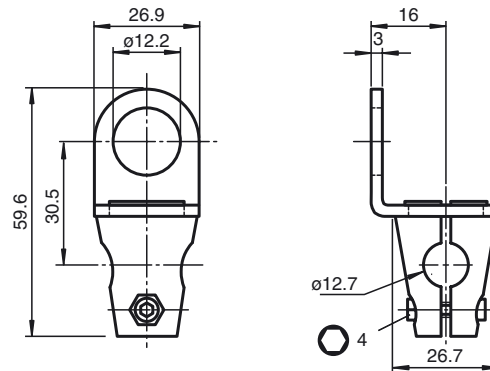

Dimensions



Model Number

MH 01-M12

Mounting brackets for sensors

Features

- Suitable for M12 sensors
- Simple and fast mounting

Technical data

Mechanical specifications

Material	Clamping cylinder: Diecast zinc Support bracket: Steel
Note	rod not included

Installation instructions

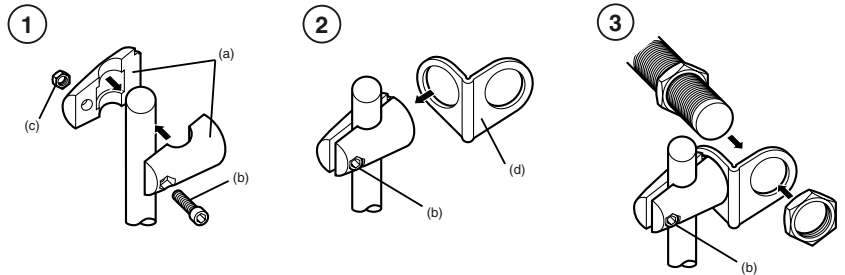

- ① Fasten the two parts of the mounting clamp (a) loosely by means of the screw (b) and the nut (c) supplied.
- ② Attach the mounting bracket (d) and then tighten the screw (b) in such a way that the bracket can still be turned.
- ③ Tighten the screw fully after the sensor has been mounted and aligned.

Release date: 2010-09-03 21:29 Date of issue: 2010-09-03 913337_ENG.xml

Subject to modifications without notice

Pepperl+Fuchs Group
www.pepperl-fuchs.com

USA: +1 330 486 0001
fa-info@us.pepperl-fuchs.com

Germany: +49 621 776-4411
fa-info@pepperl-fuchs.com

Copyright Pepperl+Fuchs
Singapore: +65 6779 9091
fa-info@sg.pepperl-fuchs.com