



**Model Number**

**MH 04-2681F**

Mounting aid for VariKont, +U1+ and +U9\*

**Features**

- Suitable for VariKont, +U1+ and +U9\* sensors
- Fixing screws for VariKont included in delivery

**Function**

The mounting bracket type 04-2681 simplifies the adjustment of sensors of the model line VariKont® and the series +U1+ and +U9\* according to DIN 43694, EN 50025 or EN 50037.

Fitting is simple using the well-trying and tested C section rail (e.g. NIEDAX GmbH) according to EN 50024 (15 mm x 30 mm x 1.5 mm). For existing installations, the mounting bracket is suitable for the C section rail according to the expiring DIN 43662 (15 mm x 30 mm x 2 mm).

Instead of the C section rail, two-point fitting is possible. The respective drill holes are accessible via the middle guiding slot. Screws M5 x 16 mm can be used.

Large adjusting ranges in x and y direction and the 360° turning range simplify and reduce the mounting and adjustment work.

The selected position can be adjusted by tightening the sensor mounting screws (included in the delivery package).

**Dimensions**

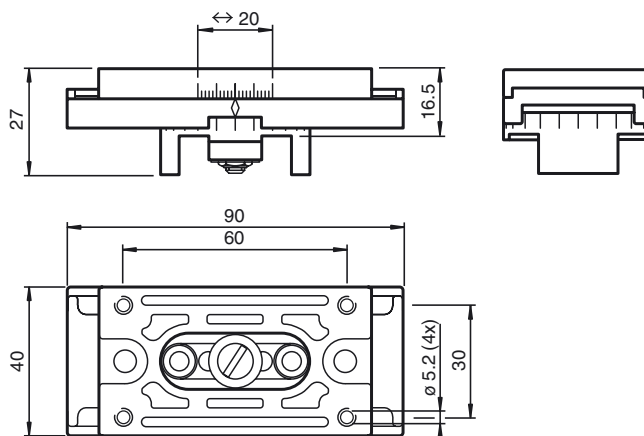

**Technical data**

**Standard conformity**

Standards IEC 68-2-6, IEC 68-2-27

**Ambient conditions**

Shock resistance  $b < 30$  g,  $T < 11$  ms

Vibration resistance  $f < 55$  Hz,  $a < 1$  mm

**Mechanical specifications**

Material Chrome coated diecast zinc

Mass approx. 270 g

Dimensions 90 mm x 40 mm x 28 mm (with 2-point fixing)

Release date: 2014-03-27 15:05 Date of issue: 2014-03-27 03:552\_eng.xml

Refer to "General Notes Relating to Pepperl+Fuchs Product Information".