



Model Number

KC-LCDC-48-6T-230VAC

LCD batch controller with 6 optocoupler outputs and 90 ... 260 V_{AC} supply voltage

Features

- Counter/Timer/Tachometer
- Adding/subtracting via 2 separate inputs
- Batch controller with 6 pre-selections
- 6 floating optocoupler outputs
- Easy-to-read, 2-line LCD display with symbols for indicated pre-selection and the status of the two outputs
- Multicolor display
- Display range and preselection range from -999999 up to 999999
Overflow will be evaluated correctly up to 1 decade
- PNP and NPN sensors can be connected
- Protection degree IP65 (front only)

Technical data

General specifications

Pre-selection	6-fold
Data storage	> 10 years, EEPROM
Programming	keypad-driven menu

Functional safety related parameters

MTTF _d	410 a
Mission Time (T _M)	10 a
Diagnostic Coverage (DC)	0 %

Indicators/operating means

Type	2-line, 2 x 6-digit LC display with leading sign Multicolor, backlighted
Display value	digit height 9 mm
Pre-selection	digit height 7 mm
Key interlock	via "high" potential at "LOCK" input
Decimal point	0 to max 5 fractional digits
Scale factor	0.0001 ... 99.9999
Reset	manually or external

Electrical specifications

Fusing	90 ... 260 V AC: T 0.1 A
Operating voltage	U _B 90 ... 260 V AC
Power consumption	P ₀ max. 8 VA

Input

Connection	Counter inputs: A and B Control/reset inputs: LOCK, RESET, GATE, MPI
------------	---

Signal voltage	
High	12 ... 30 V DC
Low	0 ... 4 V DC

Counting frequency	max. 50 kHz
Minimum pulse duration	Control/reset inputs: 10 ms / 1 ms
Impedance	5 kOhm

Count modes

Pulse counter	Counting with counting direction (cnt.dir), difference counting (up,dn), up/down counting (quad), Cumulative counting (up,up), up/down counting x 2 (quad 2), up/down counting x 4 (quad 4), additional functions for counter input A and counter input B: A/B, (A-B)/A x 100%
Frequency counter	functions for input A and input B: A, A-B, A+B quad, A/B, (A-B)/A x 100 %
Timer	Time measurement via GATE input (FrErun), counter input A: Start, counter input B: Stop (InpA.InpB.), counter input B: Start/Stop (InpB.InpB.), time measuring via RESET input (auto)

Output

Sensor supply	20.4 ... 27.6 V DC, max. 80 mA
Response time	Add/Sub/autorepeat < 6 ms A/B; (A-B)/A: < 23 ms
Optocoupler	output 1 to 6, NPN-Opto coupler output 3 to 6 with common emitter Schaltleistung 30 V DC / 10 mA
Signal voltage	U _{CESAT} bei IC = 10 mA: max. 2 V U _{CESAT} bei IC = 5 mA: max. 0.4 V

Ambient conditions

Ambient temperature	-20 ... 65 °C (253 ... 338 K)
Storage temperature	-25 ... 75 °C (248 ... 348 K)
Relative humidity	≤ 93 % at 40 °C (non-condensing)
Altitude	0 ... 2000 m
Pollution Degree	2

Mechanical specifications

Protection degree	IP65 (front)
Mass	approx. 151 g
Dimensions	48 mm x 48 mm x 109.8 mm

Compliance with standards and directives

Directive conformity	
Low Voltage Directive 2006/95/EC	EN 61010-1:2001; protection class: 2
EMC Directive 2004/108/EC	EN 61000-6-2:2005, EN 50295:1999
Standard conformity	
Emitted interference	DIN EN 55011:2009, Class B
Mech. capacity	EN 60068-2-6:2008 10 ... 55 Hz / 1 mm / XYZ 30 min in each direction



Shock and impact resistance

EN 60068-2-27:1995
100 G / 2 ms / XYZ
3 times in each direction

Release date: 2010-03-01 12:14 Date of issue: 2010-03-01 215120_ENG.xml

Dimensions

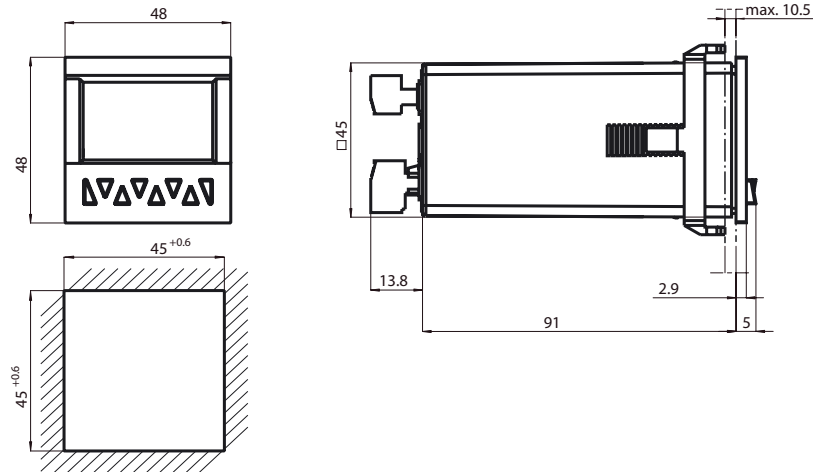

Indicators / Operating means

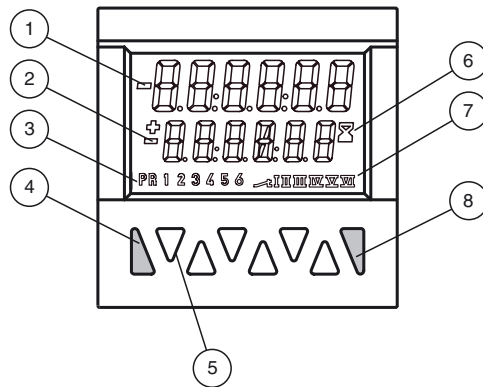

- 1 Current count value
- 2 Preset value
- 3 Indicator preset value (at 9)
- 4 Reset key
- 5 Decade keys 1 to 6 / Keys for programming
- 6 Run display for timer
- 7 Shows the active output
- 8 Prog/Mode key

Electrical connection

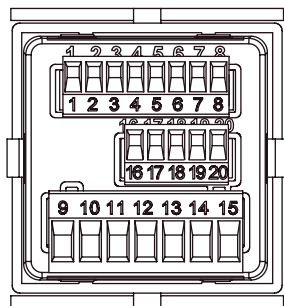

Signal and control inputs

- 1 Sensor supply voltage
- 2 GND (0V)
- 3 INP A (Signal input A)
- 4 INP B (Signal input B)
- 5 RESET (Reset input)
- 6 LOCK (Input Keypad lock)
- 7 GATE (Gate input)
- 8 MPI (User input)

Supply voltage and outputs

- 9 Collector } Output 1
- 10 Emitter } Output 1
- 11 Collector } Output 2
- 12 not connected } Output 2
- 13 Emitter } Output 2
- 14 10 ... 30 V DC } Supply voltage
- 15 GND (0V) } Supply voltage
- 16 Common Emitter } Output 3 - 6
- 17 Collector 6 } Output 6
- 18 Collector 5 } Output 5
- 19 Collector 4 } Output 4
- 20 Collector 3 } Output 3

Release date: 2010-03-01 12:14 Date of issue: 2010-03-01 2:15:20_ENG.xml