

Super-mini Signal Conditioners Mini-M Series

DC ALARM

Functions & Features

- Provides N.O. relay outputs at preset DC input levels
- Dual trip
- Multi-turn potentiometer adj.
- Monitor jacks help setpoint adj.
- Power ON timer
- Relays can be powered 110 V DC
- CE marking for 24 V DC power

Typical Applications

- Annunciator
- Various alarm applications

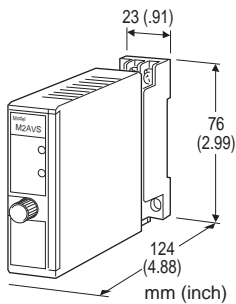

MODEL: M2AVS-[1][2][3][4]-[5][6]

ORDERING INFORMATION

- Code number: M2AVS-[1][2][3][4]-[5][6]
Specify a code from below for each [1] through [6].
(e.g. M2AVS-6112-R/CE/Q)
- Special input range (For codes Z & 0, 01)
- Specify the specification for option code /Q
(e.g. /C01/S01)

[1] INPUT

Current

- A:** 4 - 20 mA DC (Input resistance 250 Ω)
- A1:** 4 - 20 mA DC (Input resistance 50 Ω)
- B:** 2 - 10 mA DC (Input resistance 500 Ω)
- C:** 1 - 5 mA DC (Input resistance 1000 Ω)
- D:** 0 - 20 mA DC (Input resistance 50 Ω)
- E:** 0 - 16 mA DC (Input resistance 62.5 Ω)
- F:** 0 - 10 mA DC (Input resistance 100 Ω)
- G:** 0 - 1 mA DC (Input resistance 1000 Ω)
- H:** 10 - 50 mA DC (Input resistance 100 Ω)
- J:** 0 - 10 μA DC (Input resistance 1000 Ω)
- K:** 0 - 100 μA DC (Input resistance 1000 Ω)
- GW:** -1 - +1 mA DC (Input resistance 1000 Ω)

FW: -10 - +10 mA DC (Input resistance 100 Ω)

Z: Specify current (See INPUT SPECIFICATIONS)

Voltage

- 1:** 0 - 10 mV DC (Input resistance 10 kΩ min.)
- 15:** 0 - 50 mV DC (Input resistance 10 kΩ min.)
- 16:** 0 - 60 mV DC (Input resistance 10 kΩ min.)
- 2:** 0 - 100 mV DC (Input resistance 100 kΩ min.)
- 3:** 0 - 1 V DC (Input resistance 1 MΩ min.)
- 4:** 0 - 10 V DC (Input resistance 1 MΩ min.)
- 5:** 0 - 5 V DC (Input resistance 1 MΩ min.)
- 6:** 1 - 5 V DC (Input resistance 1 MΩ min.)
- 4W:** -10 - +10 V DC (Input resistance 1 MΩ min.)
- 5W:** -5 - +5 V DC (Input resistance 1 MΩ min.)
- 0:** Specify voltage (See INPUT SPECIFICATIONS)
(Select '/N' for 'Standards & Approvals' code.)
- 01:** Specify voltage (See INPUT SPECIFICATIONS)
(Select '/CE' for 'Standards & Approvals' code.)

[2] SETPOINT 1 OUTPUT

- 1:** Hi (coil energized at alarm)
- 3:** Lo (coil energized at alarm)

[3] SETPOINT 2 OUTPUT

- 1:** Hi (coil energized at alarm)
- 3:** Lo (coil energized at alarm)

[4] OUTPUT

- 2:** Relay; N.O. or make contact
- 6:** Photo MOSFET relay; N.O.

[5] POWER INPUT

AC Power

M: 85 - 264 V AC (Operational voltage range 85 - 264 V, 47 - 66 Hz)
(Select '/N' for 'Standards & Approvals' code.)

DC Power

R: 24 V DC
(Operational voltage range 24 V ±10 %, ripple 10 %p-p max.)

R2: 11 - 27 V DC
(Operational voltage range 11 - 27 V, ripple 10 %p-p max.)
(Select '/N' for 'Standards & Approvals' code.)

P: 110 V DC
(Operational voltage range 85 - 150 V, ripple 10 %p-p max.)
(Select '/N' for 'Standards & Approvals' code.)

[6] OPTIONS (multiple selections)

Standards & Approvals (must be specified)

- /N:** Without CE
- /CE:** CE marking

Other Options

blank: none

/Q: Option other than the above (specify the specification)

SPECIFICATIONS OF OPTION: Q (multiple selections)

COATING (For the detail, refer to M-System's web site.)

/C01: Silicone coating

/C02: Polyurethane coating

/C03: Rubber coating

TERMINAL SCREW MATERIAL

/S01: Stainless steel

GENERAL SPECIFICATIONS

Construction: Plug-in

Connection: M3 screw terminals (torque 0.8 N·m)

Housing material: Flame-resistant resin (black)

Isolation: Input to output 1 to output 2 to power

Setpoint adjustments: Multi-turn screwdriver adjustments (front); 0 - 100 % independently

Monitor jacks: Output 0 - 1 V for 0 - 100 % setpoints

Hysteresis (deadband): ≤ 0.5 %

Front LEDs

Output 1: Red light turns on when the coil is energized.

Output 2: Green light turns on when the coil is energized.

Power ON timer: Relays de-energized for approx. 1 seconds after power is turned on.

INPUT SPECIFICATIONS

■ **DC Current:**

Shunt resistor attached to the input terminals (0.5 W)

Specify input resistance value for code Z.

■ **DC Voltage:** -300 - +300 V DC

(-30 - +30 V for the input code 01. Span 30 V max.)

Minimum span: 3 mV

Offset: Max. 1.5 times span

• **Input resistance**

Span 3 - 10 mV : ≥ 10 kΩ

Span 10 - 100 mV : ≥ 10 kΩ

Span 0.1 - 1 V : ≥ 100 kΩ

Span ≥ 1 V : ≥ 1 MΩ

OUTPUT SPECIFICATIONS

■ **Relay Contact:**

120 V AC @0.5 A (cos φ = 1)

240 V AC @0.5 A (cos φ = 1)

30 V DC @0.5 A (resistive load)

Maximum switching voltage: 250 V AC or 120 V DC

Maximum switching power: 120 VA or 15 W (≤ 0.5 A)

Minimum load: 5 V DC @10 mA

Mechanical life: 5 × 10⁷ cycles

For maximum relay life with inductive loads, external

protection is recommended.

■ **Photo MOSFET Relay**

Maximum switching voltage: 30 V AC or 50 V DC

Maximum switching current: 0.5 A

ON resistance: ≤ 2 kΩ

Leakage current at OFF: ≤ 10 μA

For maximum relay life with inductive loads, external protection is recommended.

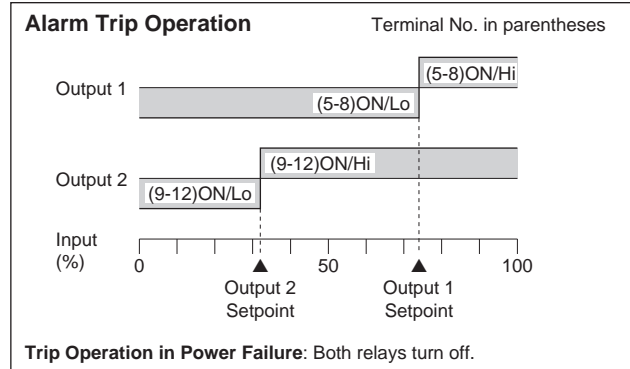

INSTALLATION

Power Consumption

• **AC:**

Approx. 3 VA at 100 V

Approx. 4 VA at 200 V

Approx. 5 VA at 264 V

• **DC:** Approx. 3 W

Operating temperature: -5 to +55°C (23 to 131°F)

Operating humidity: 30 to 90 %RH (non-condensing)

Mounting: Surface or DIN rail

Weight: 150 g (0.33 lb)

PERFORMANCE in percentage of span

Setpoint monitor accuracy: ±0.5 %

Temp. coefficient: ±0.05 %/°C (±0.03 %/°F)

Response time: ≤ 0.5 sec. (0 - 100 % at 90 % setpoint)

Line voltage effect: ±0.1 % over voltage range

Insulation resistance: ≥ 100 MΩ with 500 V DC

Dielectric strength: 2000 V AC @1 minute (input to output 1 to output 2 to power to ground)

STANDARDS & APPROVALS

CE conformity:

EMC Directive (2004/108/EC)

EMI EN 61000-6-4: 2007

EMS EN 61000-6-2: 2005

Low Voltage Directive (2006/95/EC)

EN 61010-1: 2001

Measurement Category II (output)

Installation Category II (power)

Pollution Degree 2
 Input to output to power: Basic insulation (300 V)

FRONT VIEW

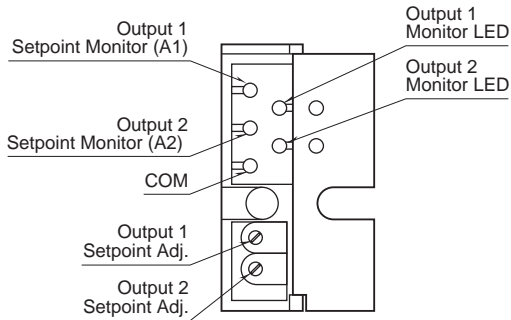

Refer to the instruction manual for detailed procedures.

DIMENSIONS unit: mm (inch)

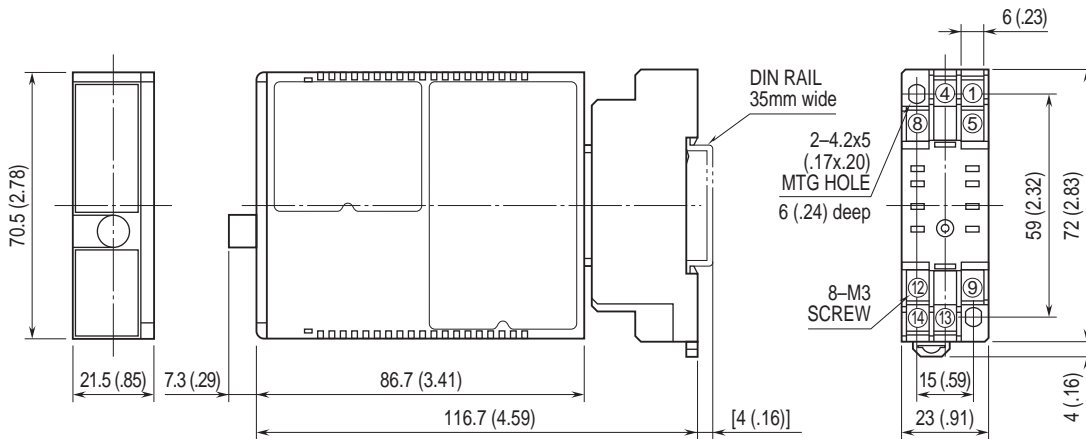

• When mounting, no extra space is needed between units.

TERMINAL ASSIGNMENTS unit: mm (inch)

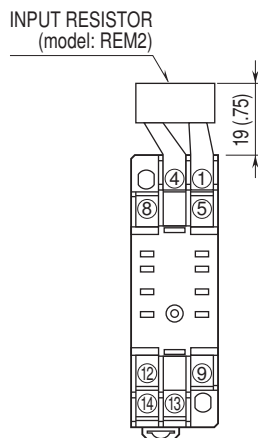

Input shunt resistor attached for current input.

SCHEMATIC CIRCUITRY & CONNECTION DIAGRAM

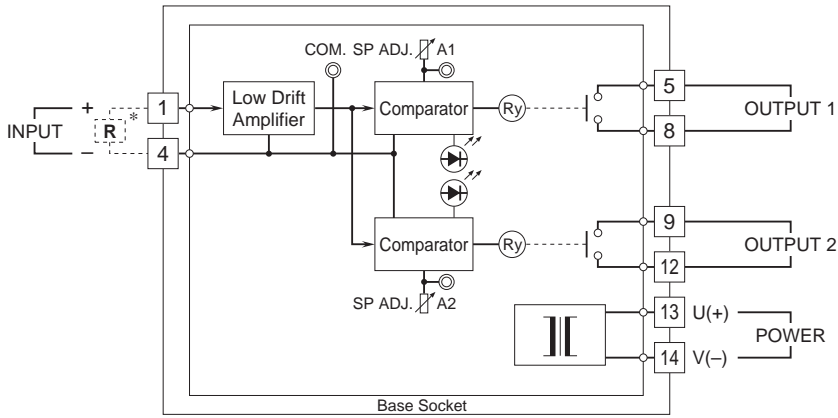

*Input shunt resistor attached for current input.

■ Relay Protection

• AC Powered

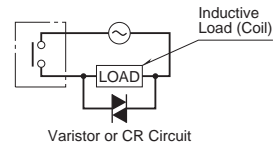

• DC Powered

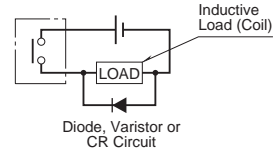

Specifications are subject to change without notice.