

Super-mini Signal Conditioners Mini-M Series

POTENTIOMETER TRANSMITTER

(field- and PC-configurable)

Functions & Features

- Provides a DC output proportional to a potentiometer or slidewire position input
- Easy 'One-Step Cal' calibration using the front three control buttons without needing a PC; PC software is also usable.
- Input range, output type and range are configurable

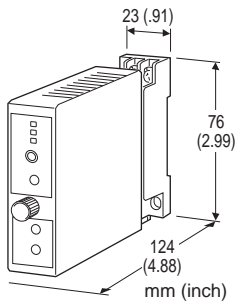

MODEL: M2LPM-1[1]-M[2]

ORDERING INFORMATION

- Code number: M2LPM-1[1]-M[2]
- Specify a code from below for each [1] and [2].
(e.g. M2LPM-1Z1-M/Q)
- Output range (e.g. 4 – 20 mA DC)
 - Specify the specification for option code /Q
(e.g. /C01/S01)

INPUT

1: Total resistance 50 Ω – 10 k Ω

(Input range are fully programmable out of the range specified when ordering by setting up the DIP switch and using 'One-Step-Cal' Calibration. PC Configurator is also available.)

[1] OUTPUT

Current

Z1: Range 0 – 20 mA DC

Voltage

V1: Range -2.5 – +2.5 V DC

V2: Range -10 – +10 V DC

Output ranges are fully programmable out of the range specified when ordering by setting up the DIP switch and using 'One-Step-Cal' Calibration. PC Configurator is also available.

POWER INPUT

AC Power

M: 85 – 264 V AC (Operational voltage range 85 – 264 V, 47 – 66 Hz)

[2] OPTIONS

blank: none

/Q: With options (specify the specification)

SPECIFICATIONS OF OPTION: Q (multiple selections)

COATING (For the detail, refer to M-System's web site.)

/C01: Silicone coating

/C02: Polyurethane coating

/C03: Rubber coating

TERMINAL SCREW MATERIAL

/S01: Stainless steel

RELATED PRODUCTS

- PC configurator software (model: M2LPMCFG)

Downloadable at M-System's web site.

A dedicated cable is required to connect the module to the PC. Please refer to the internet software download site or the users manual for the PC configurator for applicable cable types.

GENERAL SPECIFICATIONS

Construction: Plug-in

Connection: M3 screw terminals (torque 0.8 N·m)

Housing material: Flame-resistant resin (black)

Isolation: Input to output to power

Overrange output: Approx. -15 to +115 %
(Negative current output is not provided.)

Zero adjustment: -15 to +15 % (front)

Span adjustment: 85 to 115 % (front)

Burnout protection: Upscale, downscale or no burnout selectable with DIP switches

Status indicator LED: Tri-color (green/amber/red) LED; Flashing patterns indicate operation status of the transmitter.

Configuration

'One-Step Cal' calibration: With I/O type and the full-scale range configured via the side DIP switches, precise 0 % and 100 % ranges are calibrated via the front control buttons with a help of LED.

PC configurator: Via Windows PC connected to the front jack.

Programmable features include:

- I/O type and range
- Zero and span adjustments
- Burnout

• User's linearization table

Configurator connection: 2.5 dia. miniature jack;
RS-232C level

INPUT SPECIFICATIONS

• **POTENTIOMETER:** 0 – 50 Ω through 10 kΩ

If not specified, the input range is 1500 Ω.

Minimum span:

(Range) 0 – 50 Ω : 2.5 Ω

0 – 150 Ω : 5 Ω

0 – 300 Ω : 5 Ω

0 – 500 Ω : 5 Ω

0 – 1500 Ω : 150 Ω

0 – 10 kΩ : 1000 Ω

Reference voltage: 2.5 V (2.5 kΩ connected in serial)

Reference resistance: 2.5 kΩ

Excitation voltage:

$2.5 \times \text{Connected Resistance} / (\text{Connected Resistance} + 2500)$ [V]

[Example] Resistance = 1000 Ω

$2.5 \times 1000 / (1000 + 2500) = 0.7$ [V]

OUTPUT SPECIFICATIONS

• **DC Current**

Maximum range: 0 – 20 mA DC

Conformance range: 0 – 24 mA DC

Minimum span: 1 mA

Offset: Lower range can be any specific value within the output range provided that the minimum span is maintained.

Load resistance: Output drive 12 V max.

(e.g. 4 – 20 mA: 600 Ω [12 V/20 mA])

If not specified, the output range is 4 – 20 mA DC.

• **DC VOLTAGE**

Code V1 (narrow spans)

Conformance range: -3 – +3 V DC

Output range: -2.5 – +2.5 V DC

Minimum span: 250 mV

Code V2 (wide spans)

Conformance range: -11.5 – +11.5 V DC

Output range: -10 – +10 V DC

Minimum span: 1 V

Offset: Lower range can be any specific value within the output range provided that the minimum span is maintained.

Load resistance: Output drive 1 mA max.

(e.g. 1 – 5 V: 5000 Ω [5 V / 1 mA])

If not specified, the output range is shown below.

V1: 0 – 1 V DC

V2: 1 – 5 V DC

INSTALLATION

Power Consumption

• **AC Power input:**

Approx. 4 VA at 100 V

Approx. 5 VA at 200 V

Approx. 6 VA at 264 V

Operating temperature: -5 to +55°C (23 to 131°F)

Operating humidity: 30 to 90 %RH (non-condensing)

Mounting: Surface or DIN rail

Weight: 120 g (0.26 lbs)

PERFORMANCE

Overall accuracy: Input accuracy + output accuracy

Inversely proportional to the span. Except the accuracy of input resistor.

See CALCULATION EXAMPLES OF OVERALL ACCURACY.

• **Input accuracy:** (% of range)

0 – 50 Ω : ±0.02 %

0 – 150 Ω : ±0.02 %

0 – 300 Ω : ±0.01 %

0 – 500 Ω : ±0.01 %

0 – 1500 Ω : ±0.01 %

0 – 10 kΩ : ±0.01 %

• **Output accuracy:** ±0.04 % of max. output range

Temp. coefficient: ±0.015 %/°C (±0.008 %/°F) of max. span

Response time: ≤ 1 sec. (0 – 90 %)

Burnout response time: ≤ 1 sec.

Line voltage effect: ±0.1 % over voltage range

Insulation resistance: ≥ 100 MΩ with 500 V DC

Dielectric strength: 2000 V AC @1 minute (input to output to power to ground)

CALCULATION EXAMPLES OF OVERALL ACCURACY

[Example] Total Resistance 0 – 1 kΩ, Output Range 1 – 5 V

Max. Input Range (1.5 kΩ) / Span (1 kΩ) × 0.01 % = 0.015 %

Max. Output Range (20 V) / Span (4 V) × 0.04 % = 0.2 %

Overall accuracy = 0.015 + 0.2 = ±0.22 %

EXTERNAL VIEW

FRONT VIEW

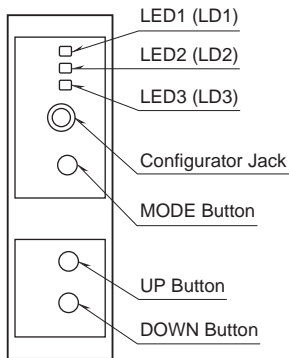

SIDE VIEW

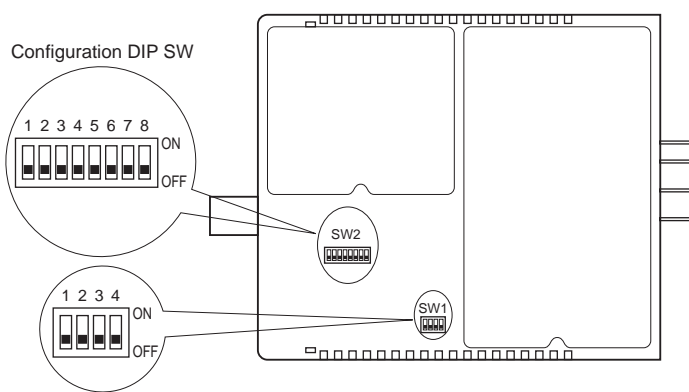

For detailed information on the configuration and calibration, refer to the instruction manual.

EXTERNAL DIMENSIONS & TERMINAL ASSIGNMENTS unit: mm (inch)

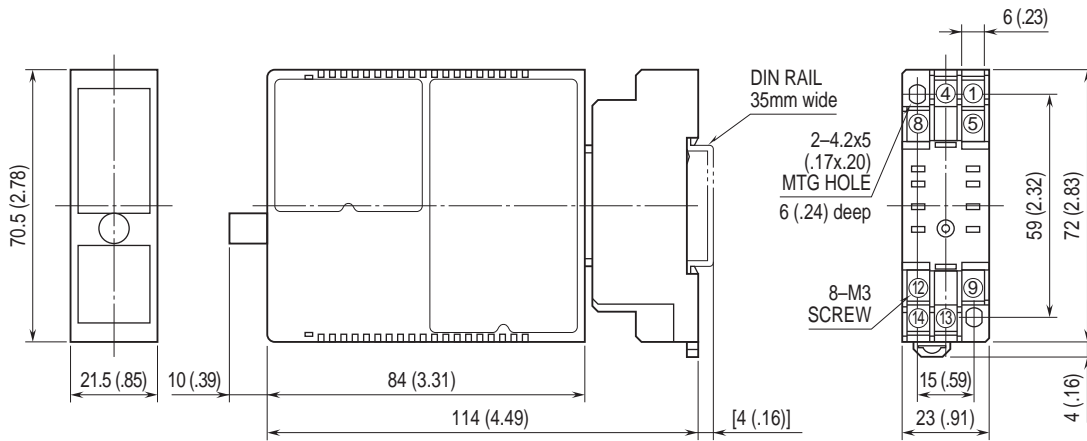

• When mounting, no extra space is needed between units.

SCHEMATIC CIRCUITRY & CONNECTION DIAGRAM

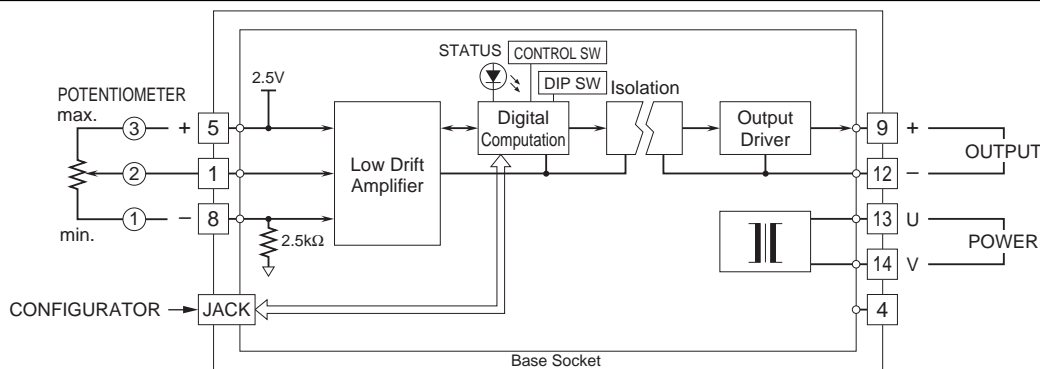

Specifications are subject to change without notice.