

Super-mini Signal Conditioners Mini-M Series

SIGNAL TRANSMITTER

(field- and PC-configurable)

Functions & Features

- Accepts a DC mV, V or mA input and provides an isolated DC signal
- Easy 'One-Step Cal' calibration using the front three control buttons without needing a PC; PC software is also usable.
- Both input and output type and range are configurable

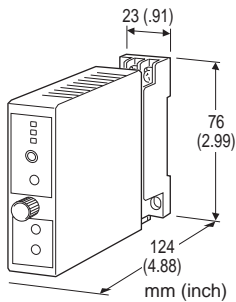

MODEL: M2LV-[1][2]-M[3]

ORDERING INFORMATION

- Code number: M2LV-[1][2]-M[3]
Specify a code from below for each [1] through [3].
(e.g. M2LV-S2Z1-M/Q)
- Input range (e.g. 0 - 5 V DC)
- Output range (e.g. 4 - 20 mA DC)
- Specify the specification for option code /Q
(e.g. /C01/S01)

[1] INPUT

Current

Z1: Range 0 - 50 mA DC (Input resistance 24.9 Ω)

Voltage

S1: Range -1000 - +1000 mV DC (Input resistance 1 MΩ min.)

S2: Range -10 - +10 V DC (Input resistance 1 MΩ min.)

(Input range are fully programmable out of the range specified when ordering by setting up the DIP switch and using 'One-Step-Cal' Calibration. PC Configurator is also available.)

[2] OUTPUT

Current

Z1: Range 0 - 20 mA DC

Voltage

V1: Range -2.5 - +2.5 V DC

V2: Range -10 - +10 V DC

Output ranges are fully programmable out of the range specified when ordering by setting up the DIP switch and using 'One-Step-Cal' Calibration. PC Configurator is also available.

POWER INPUT

AC Power

M: 85 - 264 V AC (Operational voltage range 85 - 264 V, 47 - 66 Hz)

[3] OPTIONS

blank: none

/Q: With options (specify the specification)

SPECIFICATIONS OF OPTION: Q (multiple selections)

COATING (For the detail, refer to M-System's web site.)

/C01: Silicone coating

/C02: Polyurethane coating

/C03: Rubber coating

TERMINAL SCREW MATERIAL

/S01: Stainless steel

RELATED PRODUCTS

- PC configurator software (model: M2LVCFG)

Downloadable at M-System's web site.

A dedicated cable is required to connect the module to the PC. Please refer to the internet software download site or the users manual for the PC configurator for applicable cable types.

GENERAL SPECIFICATIONS

Construction: Plug-in

Connection: M3 screw terminals (torque 0.8 N·m)

Housing material: Flame-resistant resin (black)

Isolation: Input to output to power

Overrange output: Approx. -15 to +115 %

Zero adjustment: -15 to +15 % (front)

Span adjustment: 85 to 115 % (front)

Status indicator LED: Tri-color (green/amber/red) LED;

Flashing patterns indicate operation status of the transmitter.

Configuration

'One-Step Cal' calibration: With I/O type and the full-scale range configured via the side DIP switches, precise 0 % and 100 % ranges are calibrated via the front control buttons with a help of LED.

PC configurator: Via Windows PC connected to the front jack.

Programmable features include:

- I/O type and range

- Zero and span adjustments
 - User's linearization table
- Configurator connection:** 2.5 dia. miniature jack;
RS-232C level

V1: 0 - 1 V DC
V2: 1 - 5 V DC

INPUT SPECIFICATIONS

- **DC Current:** Input resistor incorporated
(If not specified, the input range is 4 - 20 mA DC.)
Input range: 0 - 50 mA DC
Minimum span: 2 mA
Offset: Lower range can be any specific value within the input range provided that the minimum span is maintained.
- **DC Voltage**
Code S1 (narrow spans)
Input range: -1000 - +1000 mV DC
Minimum span: 100 mV
Code S2 (wide spans)
Input range: -10 - +10 V DC
Minimum span: 1 V
Offset: Lower range can be any specific value within the input range provided that the minimum span is maintained.
If not specified, the input range is shown below.
S1: 0 - 100 mV DC
S2: 1 - 5 V DC

OUTPUT SPECIFICATIONS

- **DC Current**
Maximum range: 0 - 20 mA DC
Conformance range: 0 - 24 mA DC
Minimum span: 1 mA
Offset: Lower range can be any specific value within the output range provided that the minimum span is maintained.
Load resistance: Output drive 12 V max.
(e.g. 4 - 20 mA: 600 Ω [12 V/20 mA])
If not specified, the output range is 4 - 20 mA DC.
- **DC VOLTAGE**
Code V1 (narrow spans)
Conformance range: -3 - +3 V DC
Output range: -2.5 - +2.5 V DC
Minimum span: 250 mV
Code V2 (wide spans)
Conformance range: -11.5 - +11.5 V DC
Output range: -10 - +10 V DC
Minimum span: 1 V
Offset: Lower range can be any specific value within the output range provided that the minimum span is maintained.
Load resistance: Output drive 1 mA max.
(e.g. 1 - 5 V: 5000 Ω [5 V / 1 mA])
If not specified, the output range is shown below.

INSTALLATION

Power Consumption

- **AC Power input:**
Approx. 4 VA at 100 V
Approx. 5 VA at 200 V
Approx. 6 VA at 264 V

Operating temperature: -5 to +55°C (23 to 131°F)
Operating humidity: 30 to 90 %RH (non-condensing)
Mounting: Surface or DIN rail
Weight: 120 g (0.26 lbs)

PERFORMANCE

- Accuracy:** Input accuracy + output accuracy
Inversely proportional to the span.
Except the accuracy of input resistor.
See CALCULATION EXAMPLES OF OVERALL ACURACY.
- Input accuracy:** (% of input range)
-1000 - +1000 mV : $\leq \pm 0.01 \%$
-10 - +10 V : $\leq \pm 0.01 \%$
0 - 50 mA : $\leq \pm 0.02 \%$
- Output accuracy:** $\pm 0.04 \%$ of output range
- Temp. coefficient:** $\pm 0.015 \%/^{\circ}\text{C}$ ($\pm 0.008 \%/^{\circ}\text{F}$) of max. span
- Response time:** ≤ 1 sec. (0 - 90 %)
- Line voltage effect:** $\pm 0.1 \%$ over voltage range
- Insulation resistance:** $\geq 100 \text{ M}\Omega$ with 500 V DC
- Dielectric strength:** 2000 V AC @1 minute (input to output to power to ground)

CALCULATION EXAMPLES OF OVERALL ACCURACY

- [Example] Input Type -10 - +10 V, Input Range 1 - 5 V,
Output Type -10 - +10 V, Output Range 1 - 5 V
- Input accuracy = Max. Input Range (20 V) / Span (4 V) \times 0.01 % = 0.05 %
 - Output accuracy = Max. Output Range (20 V) / Span (4 V) \times 0.04 % = 0.2 %
- Accuracy = $\pm 0.25 \%$

EXTERNAL VIEW

FRONT VIEW

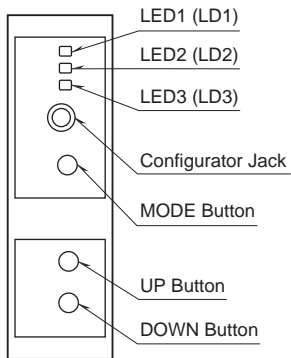

SIDE VIEW

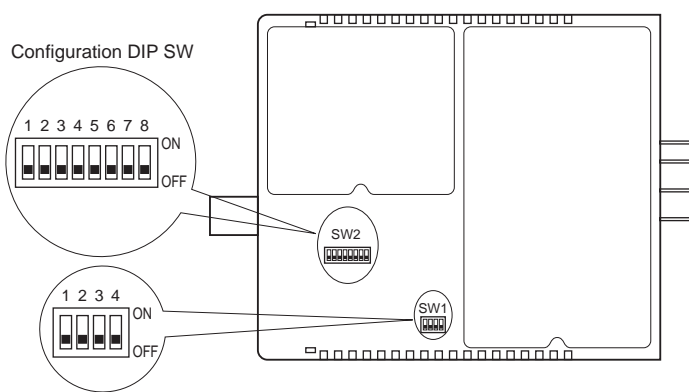

For detailed information on the configuration and calibration, refer to the instruction manual.

EXTERNAL DIMENSIONS & TERMINAL ASSIGNMENTS unit: mm (inch)

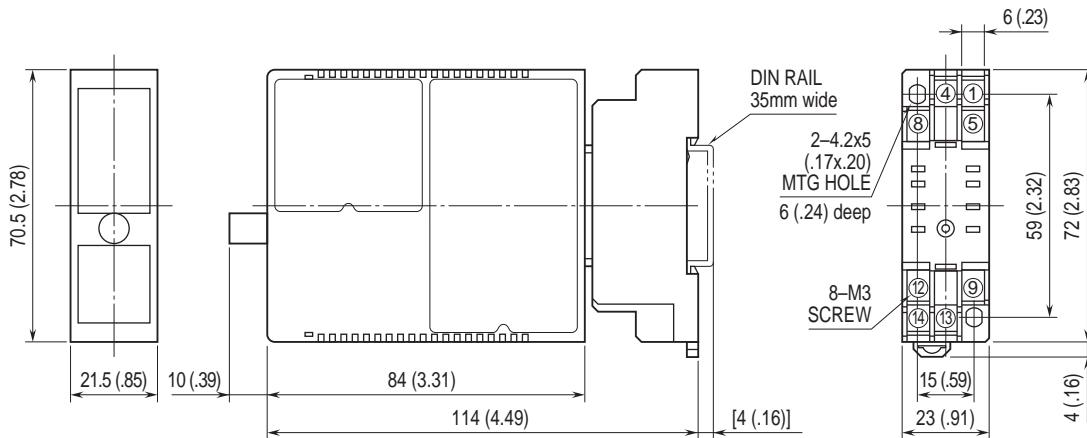

• When mounting, no extra space is needed between units.

SCHEMATIC CIRCUITRY & CONNECTION DIAGRAM

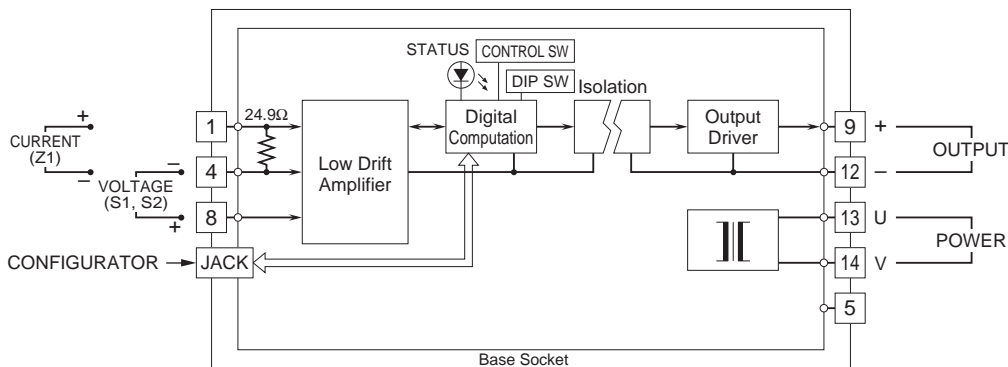

Specifications are subject to change without notice.