

Super-mini Signal Conditioners Mini-M Series

ANALOG SWITCHING MODULE

Functions & Features

- Switches between two analog signal channels
- Switches/Distributes one voltage signal to two channels
- CE marking

Typical Applications

- Switching 1 - 5V DC signal: no contact failure that happens when using mechanical contacts for this purpose
- Switching low-speed pulse signals

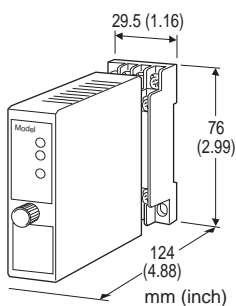

MODEL: M2MNV-[1][2]-[3][4]

ORDERING INFORMATION

- Code number: M2MNV-[1][2]-[3][4]
- Specify a code from below for each [1] through [4].
(e.g. M2MNV-11-M2/CE/Q)
- Specify the specification for option code /Q
(e.g. /C01/S01)

Note: Must be used with its socket. NOT installable to a multi-unit installation base. (e.g. model: M2BS-16)

[1] SWITCHING CONTROL

- 1: Interlocking switching control (single-pole contact)
- 2: Independent switching control (double-pole contact)

[2] INPUT

- 1: Current signal (no receiving resistor)
- 2: Current signal (receiving resistor 50 Ω)
- 3: Voltage signal

[3] POWER INPUT

AC Power

M: 85 - 264 V AC (Operational voltage range 85 - 264 V, 47 - 66 Hz)
(Select '/N' for 'Standards & Approvals' code.)

M2: 100 - 240 V AC (Operational voltage range 85 - 264 V, 47 - 66 Hz)

DC Power

R: 24 V DC
(Operational voltage range 24 V ±10 %, ripple 10 %p-p max.)

R2: 11 - 27 V DC
(Operational voltage range 11 - 27 V, ripple 10 %p-p max.)
(Select '/N' for 'Standards & Approvals' code.)

P: 110 V DC
(Operational voltage range 85 - 150 V, ripple 10 %p-p max.)

[4] OPTIONS (multiple selections)

Standards & Approvals (must be specified)

/N: Without CE

/CE: CE marking

Other Options

blank: none

/Q: Option other than the above (specify the specification)

SPECIFICATIONS OF OPTION: Q (multiple selections)

COATING (For the detail, refer to M-System's web site.)

/C01: Silicone coating

/C02: Polyurethane coating

/C03: Rubber coating

TERMINAL SCREW MATERIAL

/S01: Stainless steel

GENERAL SPECIFICATIONS

Construction: Plug-in

Connection: M3 screw terminals (torque 0.8 N·m)

Housing material: Flame-resistant resin (black)

Switching: Photo MOS relay

Isolation: Signal channel to switching command contact to power

Power indicator LED: Green light turns on when the power is supplied.

Status indicator LED 1: Green light turns on when the signal channel 1 (A1-B1) is alive.

Status indicator LED 2: Green light turns on when the signal channel 2 (A2-B1) is alive.

INPUT & OUTPUT

■ Signal Channels

Max. operational voltage range: ±50 V DC (min. span 10 mV)

Max. operational current range: ±50 mA DC (min. span 1 mA)

Receiving resistor: 50 Ω incorporated (input code 2)

ON resistance: ≤ 50 Ω per wire

(ON resistance of photo MOS relay)

■ Output

insulation (300 V)

Current signal input (no receiving resistor):

Equal to the input signal

Current signal input (receiving resistor 50 Ω):

Voltage signal equal to [Current × 50 Ω]

Voltage signal input: Equal to the input signal

■ Switching Command: Relay or open collector

Contact detecting: 5 V DC / 1 mA

Detecting levels: ≤ 1 kΩ at ON / ≥ 10 kΩ at OFF

INSTALLATION

Power Consumption

•AC Power input:

Approx. 3 VA at 100 V

Approx. 4 VA at 200 V

Approx. 5 VA at 264 V

•DC power input: Approx. 2 W

Operating temperature: -5 to +55°C (23 to 131°F)

Operating humidity: 30 to 90 %RH (non-condensing)

Mounting: Surface or DIN rail

Weight: 150 g (0.33 lbs)

PERFORMANCE in percentage of span

Accuracy: ±0.1 % (input code 2)

Temp. coefficient: ±0.010 %/°C (±0.006 %/°F) (input code 2)

Switching response time: ≤ 5 msec.

Leakage current at open circuit: ≤ 1 μA

Line voltage effect: ±0.1 % over voltage range

Insulation resistance: ≥ 100 MΩ with 500 V DC
(signal channel to switching command contact to power)

Dielectric strength:

2000 V AC @1 minute

(switching command contact to power to ground)

2000 V AC @1 minute

(signal channel to power to ground)

1500 V AC @1 minute

(signal channel to switching command contact)

STANDARDS & APPROVALS

CE conformity:

EMC Directive (2004/108/EC)

EMI EN 61000-6-4: 2007

EMS EN 61000-6-2: 2005

Low Voltage Directive (2006/95/EC)

EN 61010-1: 2001

Installation Category II

Pollution Degree 2

Signal channel or switching command contact to power:

Reinforced insulation (300 V)

Signal channel to switching command contact: Basic

EXTERNAL VIEW

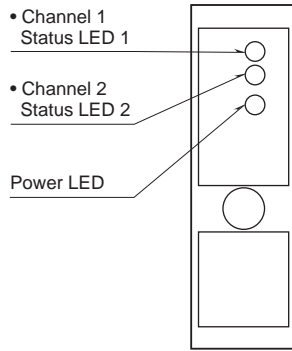

DIMENSIONS unit: mm (inch)

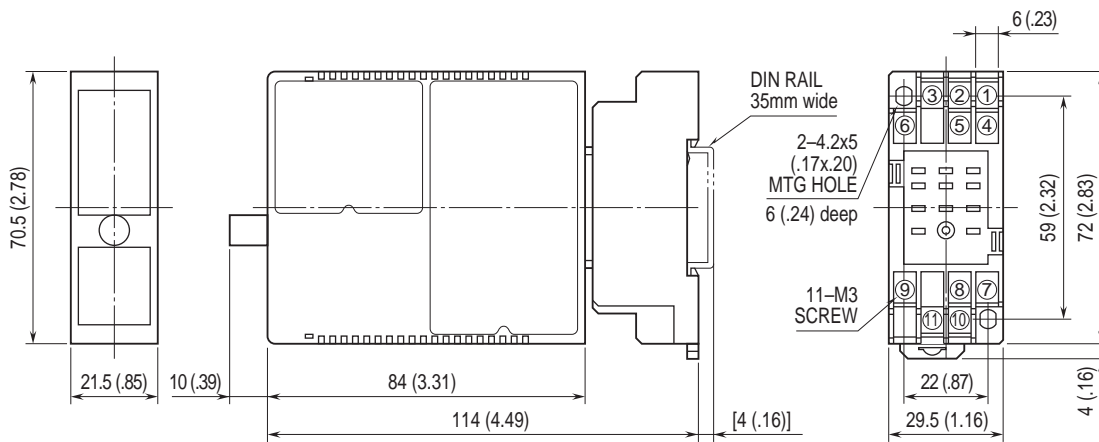

• When mounting, no extra space is needed between units.

SCHEMATIC CIRCUITRY & CONNECTION DIAGRAM

■ INTERLOCKING SWITCHING CONTROL (single-pole contact)

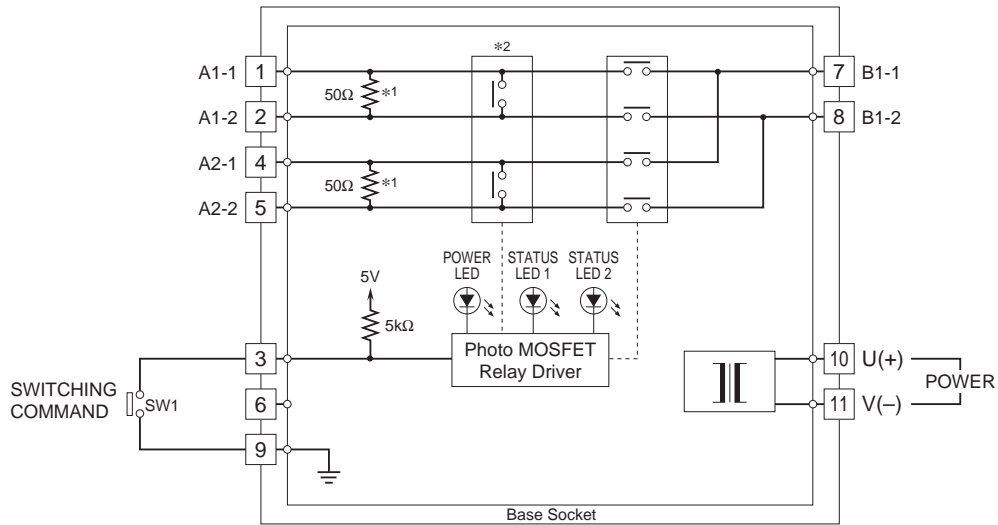

*1. Provided only with the input code 2: Current signal (receiving resistor 50Ω).
 *2. Provided only with the input code 1: Current signal (no receiving resistor).
 *1/*2 Not provided with the input code 3.
 A1-B1 channel is connected when the SW1 is turned on (closed).
 A2-B1 channel is connected when the SW1 is turned off (open).

■ INDEPENDENT SWITCHING CONTROL (double-pole contact)

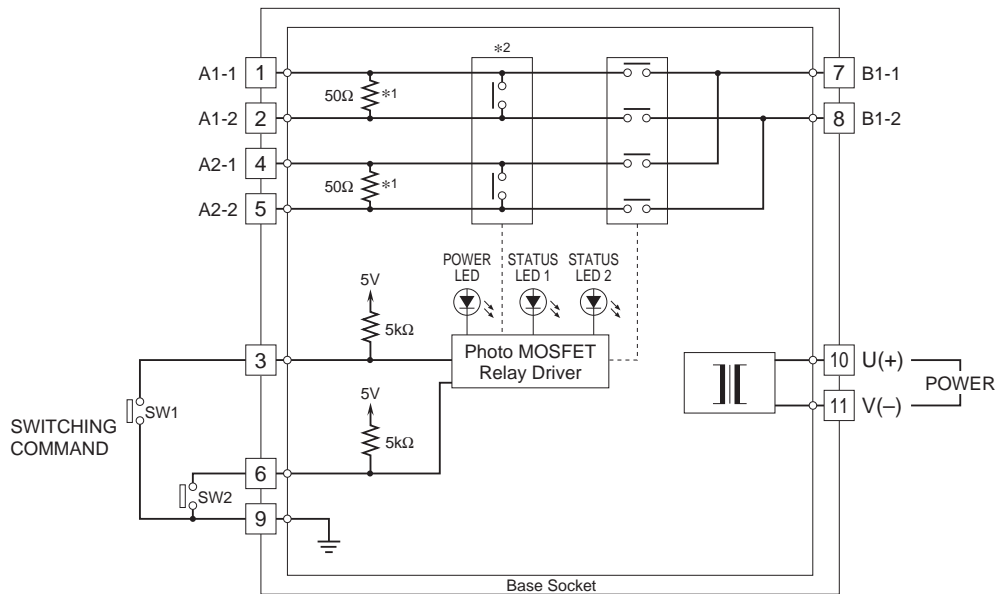

*1. Provided only with the input code 2: Current signal (receiving resistor 50Ω).
 *2. Provided only with the input code 1: Current signal (no receiving resistor).
 *1/*2 Not provided with the input code 3.
 A1-B1 channel is connected when the SW1 is turned on (closed).
 A2-B1 channel is connected when the SW2 is turned on (closed).

SWITCHING OPERATIONS

■ INTERLOCKING SWITCHING CONTROL (single-pole contact)

Single contact is used to switch from Signal Channel 1 (A1-B1) to Signal Channel 2 (A2-B1) and vice versa.

	CHANNEL 1 (A1)	CHANNEL 2 (A2)
Terminal 3 – 9 OFF (open)	OFF	ON
Terminal 3 – 9 ON (closed)	ON	OFF

Status LED turn on when the respective channels are alive.

• Switching Status

	Current Signal (no receiving resistor)	Current Signal (receiving resistor 50Ω) Voltage Signal
Power : OFF Switching command : OFF (open)		
Power : ON Switching command : OFF (open)		
Power : ON Switching command : ON (short)		

*1. Resistor is provided only for the input code 2: Current signal (receiving resistor 50Ω).

	Transition (ON to OFF, OFF to ON) Status	
	Current Signal (no receiving resistor)	Current Signal (receiving resistor 50Ω) Voltage Signal
Power : ON Switching command : OFF to ON or Power : ON Switching command : ON to OFF	<p>When the switching command contact is switched from OFF to ON or from ON to OFF, the signal channel is switched only after all photo MOS relays turn on (closed).</p>	<p>When the switching command contact is switched from OFF to ON or from ON to OFF, the signal channel is switched only after all photo MOS relays turn off (open).</p>

*1. Resistor is provided only for the input code 2: Current signal (receiving resistor 50Ω).

■ INDEPENDENT SWITCHING CONTROL (double-pole contact)

Double contacts are used to independently switch Signal Channel 1 (A1-B1) and Signal Channel 2 (A2-B1).

	CHANNEL 1 (A1)	CHANNEL 2 (A2)
Terminal 3 – 9 OFF (open)	OFF	----
Terminal 3 – 9 ON (closed)	ON	----
Terminal 6 – 9 OFF (open)	----	OFF
Terminal 6 – 9 ON (closed)	----	ON

Status LED turn on when the respective channels are alive.



Specifications are subject to change without notice.