

Super-mini Signal Conditioners Mini-M Series

POTENTIOMETER TRANSMITTER

Functions & Features

- Provides a DC output proportional to a potentiometer or slidewire position input
- Constant voltage excitation allows use with pots with total resistances from 100 – 10 kΩ without affecting accuracy
- 50 % zero/span adjustments with minimal interaction
- Fast response type available
- CE marking
- UL approval

Typical Applications

- Tank levels
- Positions

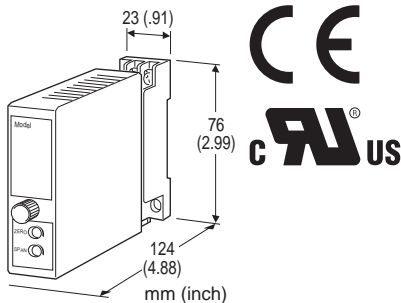

MODEL: M2MS-[1]-[2][3]

ORDERING INFORMATION

- Code number: M2MS-[1]-[2][3]
- Specify a code from below for each [1] through [3]. (e.g. M2MS-A-P/K/CE/Q)
- Special output range (For codes Z & 0)
- Specify the specification for option code /Q (e.g. /C01/S01)

INPUT

Total resistance 100 Ω – 10 kΩ

[1] OUTPUT

Current

- A:** 4 – 20 mA DC (Load resistance 750 Ω max.)
- B:** 2 – 10 mA DC (Load resistance 1500 Ω max.)
- C:** 1 – 5 mA DC (Load resistance 3000 Ω max.)
- D:** 0 – 20 mA DC (Load resistance 750 Ω max.)
- E:** 0 – 16 mA DC (Load resistance 900 Ω max.)
- F:** 0 – 10 mA DC (Load resistance 1500 Ω max.)
- G:** 0 – 1 mA DC (Load resistance 15 kΩ max.)
- Z:** Specify current (See OUTPUT SPECIFICATIONS)

Voltage

- 1:** 0 – 10 mV DC (Load resistance 10 kΩ min.)
- 2:** 0 – 100 mV DC (Load resistance 100 kΩ min.)
- 3:** 0 – 1 V DC (Load resistance 1000 Ω min.)
- 4:** 0 – 10 V DC (Load resistance 10 kΩ min.)
- 5:** 0 – 5 V DC (Load resistance 5000 Ω min.)
- 6:** 1 – 5 V DC (Load resistance 5000 Ω min.)
- 4W:** -10 – +10 V DC (Load resistance 10 kΩ min.)
- 5W:** -5 – +5 V DC (Load resistance 5000 Ω min.)
- 0:** Specify voltage (See OUTPUT SPECIFICATIONS)

[2] POWER INPUT

AC Power

M: 85 – 264 V AC (Operational voltage range 85 – 264 V, 47 – 66 Hz)

(Select '/N' for 'Standards & Approvals' code.)

M2: 100 – 240 V AC (Operational voltage range 85 – 264 V, 47 – 66 Hz)

(90 – 264 V for UL)

DC Power

R: 24 V DC

(Operational voltage range 24 V ±10 %, ripple 10 %p-p max.)

R2: 11 – 27 V DC

(Operational voltage range 11 – 27 V, ripple 10 %p-p max.)

(Select '/N' for 'Standards & Approvals' code.)

P: 110 V DC

(Operational voltage range 85 – 150 V, ripple 10 %p-p max.)

(110 V ±10 % for UL)

[3] OPTIONS (multiple selections)

RESPONSE TIME (0 - 90 %)

blank: Standard (≤ 0.5 sec.)

/K: Fast Response (Approx. 25 msec.)

STANDARDS & APPROVALS (must be specified)

/N: Without CE or UL

/CE: CE marking

/UL: UL approval (CE marking)

OTHER OPTIONS

blank: none

/Q: Option other than the above (specify the specification)

(UL not available)

SPECIFICATIONS OF OPTION: Q

COATING (For the detail, refer to M-System's web site.)

/C01: Silicone coating

/C02: Polyurethane coating

/C03: Rubber coating

TERMINAL SCREW MATERIAL

/S01: Stainless steel

GENERAL SPECIFICATIONS

Construction: Plug-in
Connection: M3 screw terminals (torque 0.8 N·m)
Housing material: Flame-resistant resin (black)
Isolation: Input to output to power
Zero adjustment: 0 – 50 % of total resistance (front)
Span adjustment: 50 – 100 % of total resistance (front)

INPUT SPECIFICATIONS

Minimum span: 50 % of total resistance
Excitation: 0.5 V DC

OUTPUT SPECIFICATIONS

• **DC Current:** 0 – 20 mA DC
Minimum span: 1 mA
Offset: Max. 1.5 times span
Load resistance: Output drive 15 V max.
• **DC Voltage:** -10 – +12 V DC
Minimum span: 5 mV
Offset: Max. 1.5 times span
Load resistance: Output drive 1 mA max.; at ≥ 0.5 V

INSTALLATION

Power Consumption
• **AC Power input:**
Approx. 3 VA at 100 V
Approx. 4 VA at 200 V
Approx. 5 VA at 264 V
• **DC Power input:** Approx. 3 W
Operating temperature: -5 to +55°C (23 to 131°F)
Operating humidity: 30 to 90 %RH (non-condensing)
Mounting: Surface or DIN rail
Weight: 150 g (0.33 lbs)

PERFORMANCE in percentage of span

Accuracy: ± 0.1 %
Temp. coefficient: ± 0.015 %/°C (± 0.008 %/°F)
Line voltage effect: ± 0.1 % over voltage range
Insulation resistance: ≥ 100 M Ω with 500 V DC
Dielectric strength: 2000 V AC @1 minute (input to output to power to ground)

STANDARDS & APPROVALS

CE conformity:
EMC Directive (2004/108/EC)
EMI EN 61000-6-4
EMS EN 61000-6-2
Low Voltage Directive (2006/95/EC)
EN 61010-1
Installation Category II

Pollution Degree 2
Input or output to power: Reinforced insulation (300 V)
Input to output: Basic insulation (300 V)

Approval:
UL/C-UL nonincendive Class I, Division 2,
Groups A, B, C, and D hazardous locations
(ANSI/ISA-12.12.01, CAN/CSA-C22.2 No.213)
UL/C-UL general safety requirements
(UL 61010-1, CAN/CSA-C22.2 No.61010-1)

DIMENSIONS unit: mm (inch)

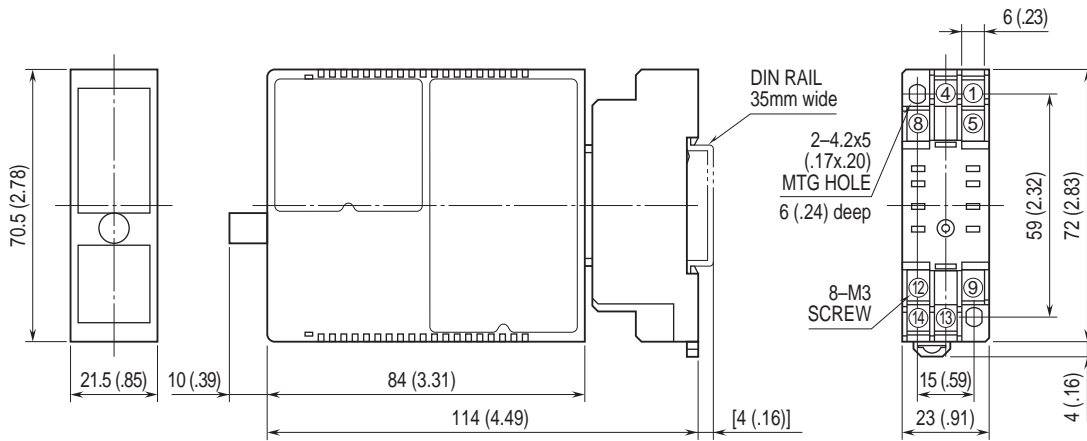

• When mounting, no extra space is needed between units.

SCHEMATIC CIRCUITRY & CONNECTION DIAGRAM

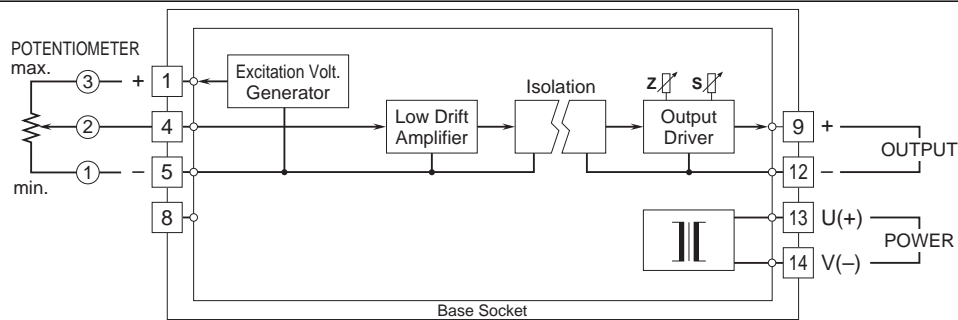

Specifications are subject to change without notice.