

Super-mini Signal Conditioners Mini-M Series

RTD TRANSMITTER

Functions & Features

- Accepts direct input from an RTD
- Linearization
- Burnout
- "Active bridge" circuit containing two constant current sources allows large leadwire resistances up to 200 Ω
- Fast response type available
- CE marking
- UL approval

Typical Applications

- Long distance transmission between the RTD and the transmitter
- Combination with intrinsic safety barriers

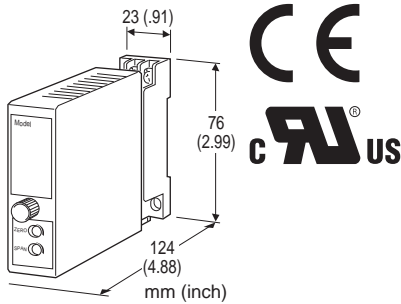

MODEL: M2RS-[1][2]-[3][4]

ORDERING INFORMATION

- Code number: M2RS-[1][2]-[3][4]
Specify a code from below for each [1] through [4].
(e.g. M2RS-4A-M2/BL/CE/Q)
- Temperature range (e.g. 0 - 500°C)
- Special output range (For codes Z & 0)
- Specify the specification for option code /Q
(e.g. /C01/V01)

For the input code C, specify also the following. If not specified, Cu 10Ω @25°C (usable range -200 - +260°C) will be used.

- Input type (e.g. Cu 10Ω)
- Resistance range (e.g. 9.038 - 12.891 Ω)

[1] INPUT RTD (2- or 3-wire)

1: JPt 100 (JIS'89)

(Usable range: -200 to +500°C, -328 to +932°F; min.span: 50°C, 90°F)

3: Pt 100 (JIS'89)

(Usable range: -200 to +650°C, -328 to +1202°F; min.span: 50°C, 90°F)

4: Pt 100 (JIS'97, IEC)

(Usable range: -200 to +500°C, -328 to +1202°F; min.span: 50°C, 90°F)

5: Pt 50 Ω (JIS'81)

(Usable range: -200 to +500°C, -328 to +932°F; min.span: 100°C, 180°F)

6: Ni 508.4 Ω

(Usable range: -50 to +200°C, -58 to +392°F; min.span: 30°C, 54°F)

C: Cu (Refer to 'Cu INPUT'.)

0: Specify

[2] OUTPUT

Current

A: 4 - 20 mA DC (Load resistance 750 Ω max.)

B: 2 - 10 mA DC (Load resistance 1500 Ω max.)

C: 1 - 5 mA DC (Load resistance 3000 Ω max.)

D: 0 - 20 mA DC (Load resistance 750 Ω max.)

E: 0 - 16 mA DC (Load resistance 900 Ω max.)

F: 0 - 10 mA DC (Load resistance 1500 Ω max.)

G: 0 - 1 mA DC (Load resistance 15 kΩ max.)

Z: Specify current (See OUTPUT SPECIFICATIONS)

Voltage

1: 0 - 10 mV DC (Load resistance 10 kΩ min.)

2: 0 - 100 mV DC (Load resistance 100 kΩ min.)

3: 0 - 1 V DC (Load resistance 1000 Ω min.)

4: 0 - 10 V DC (Load resistance 10 kΩ min.)

5: 0 - 5 V DC (Load resistance 5000 Ω min.)

6: 1 - 5 V DC (Load resistance 5000 Ω min.)

0: Specify voltage (See OUTPUT SPECIFICATIONS)

[3] POWER INPUT

AC Power

M: 85 - 264 V AC (Operational voltage range 85 - 264 V, 47 - 66 Hz)

(Select 'N' for 'Standards & Approvals' code.)

M2: 100 - 240 V AC (Operational voltage range 85 - 264 V, 47 - 66 Hz)

(90 - 264 V for UL)

DC Power

R: 24 V DC

(Operational voltage range 24 V ±10 %, ripple 10 %p-p max.)

R2: 11 - 27 V DC

(Operational voltage range 11 - 27 V, ripple 10 %p-p max.)

(Select 'N' for 'Standards & Approvals' code.)

P: 110 V DC

(Operational voltage range 85 - 150 V, ripple 10 %p-p max.)

(110 V ±10 % for UL)

[4] OPTIONS (multiple selections)

RESPONSE TIME (0 - 90 %)

blank: Standard (≤ 0.5 sec.)

/K: Fast Response (Approx. 25 msec.)

BURNOUT

blank: Upscale burnout

/BL: Downscale burnout

STANDARDS & APPROVALS (must be specified)

/N: Without CE or UL

/CE: CE marking

/UL: UL approval (CE marking)

OTHER OPTIONS

blank: none

/Q: Option other than the above (specify the specification)
(UL not available)

SPECIFICATIONS OF OPTION: Q (multiple selections)

COATING (For the detail, refer to M-System's web site.)

/C01: Silicone coating

/C02: Polyurethane coating

/C03: Rubber coating

ADJUSTMENT

/V01: Multi-turn fine adjustment

TERMINAL SCREW MATERIAL

/S01: Stainless steel

GENERAL SPECIFICATIONS

Construction: Plug-in

Connection: M3 screw terminals (torque 0.8 N·m)

Housing material: Flame-resistant resin (black)

Isolation: Input to output to power

Overrange output: Approx. -10 to +120 % at 1 - 5 V

Zero adjustment: -5 to +5 % (front)

Span adjustment: 95 to 105 % (front)

Linearization: Standard (not available for the input code C)

INPUT SPECIFICATIONS

INPUT: 2- or 3-wire RTD (Refer to 'Cu Input' for the input code C.)

Maximum leadwire resistance: 200 Ω per wire (3-wire)

Sensing current: 2 mA (Pt); 1 mA (Ni 508.4 Ω)

OUTPUT SPECIFICATIONS

• **DC Current:** 0 - 20 mA DC

Minimum span: 1 mA

Offset: Max. 1.5 times span

Load resistance: Output drive 15 V max.

• **DC Voltage:** -10 - +12 V DC

Minimum span: 5 mV

Offset: Max. 1.5 times span

Load resistance: Output drive 1 mA max.; at ≥ 0.5 V

INSTALLATION

Power Consumption

• **AC Power input:**

Approx. 3 VA at 100 V

Approx. 4 VA at 200 V

Approx. 5 VA at 264 V

• **DC Power input:** Approx. 3 W

Operating temperature: -5 to +55°C (23 to 131°F)

Operating humidity: 30 to 90 %RH (non-condensing)

Mounting: Surface or DIN rail

Weight: 150 g (0.33 lbs)

PERFORMANCE in percentage of span

Accuracy: ±0.2 %

Refer to 'Cu INPUT' for the input code C.

Temp. coefficient: ±0.015 %/°C (±0.008 %/°F)

Refer to 'Cu Input' for the input code C.

Burnout response: ≤ 10 sec.

Line voltage effect: ±0.1 % over voltage range

Insulation resistance: ≥ 100 MΩ with 500 V DC

Dielectric strength: 2000 V AC @1 minute (input to output to power to ground)

Cu INPUT

■ **INPUT**

• **Sensing current (resistance span):**

140 Ω ≤ Span ≤ 300 Ω : 1 mA

12 Ω ≤ Span < 140 Ω : 2 mA

8 Ω ≤ Span < 12 Ω : 3 mA

3.5 Ω ≤ Span < 8 Ω : 5 mA

• **Max. leadwire resistance:**

200 Ω or the value calculated using the equation below, whichever is smaller.

Leadwire resistance(Ω) = (2500 - 100% resistance(Ω) × Sensing current(mA)) ÷ (3 × Sensing current(mA))

• **Usable range:**

3.5 Ω ≤ Resistance span(Ω) ≤ 300Ω

100 % resistance(Ω) < (2500 - 3 × Leadwire resistance (Ω) × Sensing current (mA)) ÷ Sensing current (mA)

■ **PERFORMANCE**

• **Accuracy**

Resistance span ≥ 20 Ω: ±0.2 %

Otherwise use the equation below:

Accuracy(%) = 0.02(Ω) ÷ Resistance span(Ω) × 100 + 0.1(%) × 40(mV) ÷ (Resistance span(Ω) × Sensing current(mA))

• **Temperature coefficient**

Resistance span(Ω) × Sensing current(mA) ≥ 40(mV): ±0.015 %/°C

Otherwise use the equation below:

Temperature coefficient(%/°C) = 0.015(%/°C) × 40(mV) ÷ (Resistance span(Ω) × Sensing current(mA))

STANDARDS & APPROVALS

CE conformity:

EMC Directive (2004/108/EC)

EMI EN 61000-6-4

EMS EN 61000-6-2

Low Voltage Directive (2006/95/EC)

EN 61010-1

Installation Category II

Pollution Degree 2

Input or output to power: Reinforced insulation (300 V)

Input to output: Basic insulation (300 V)

Approval:

UL/C-UL nonincendive Class I, Division 2,

Groups A, B, C, and D hazardous locations

(ANSI/ISA-12.12.01, CAN/CSA-C22.2 No.213)

UL/C-UL general safety requirements

(UL 61010-1, CAN/CSA-C22.2 No.61010-1)

DIMENSIONS unit: mm (inch)

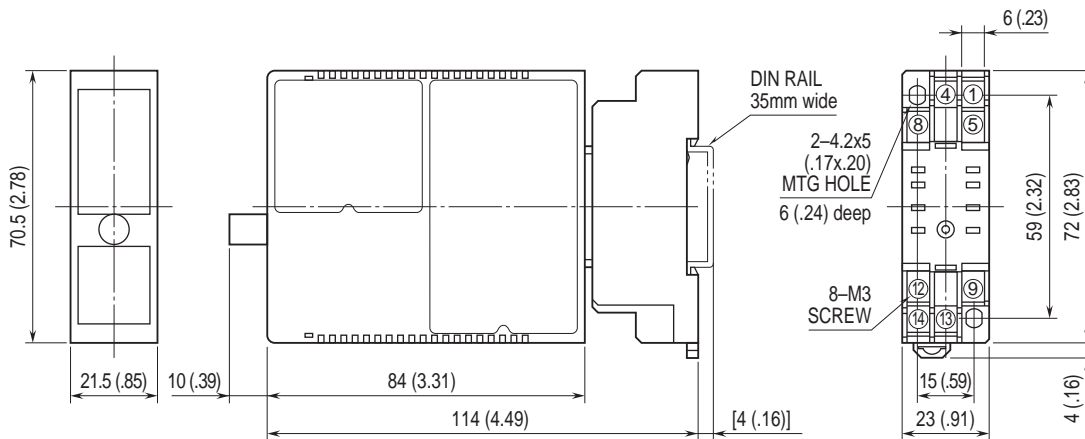

• When mounting, no extra space is needed between units.

SCHEMATIC CIRCUITRY & CONNECTION DIAGRAM

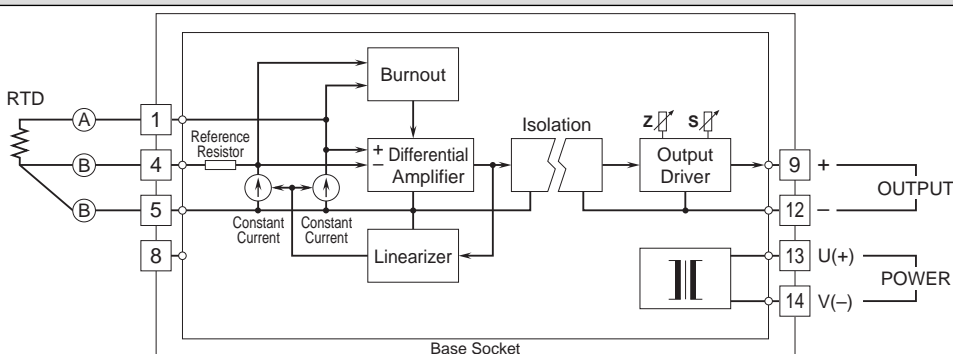

Specifications are subject to change without notice.