

Super-mini Signal Conditioners Mini-M Series

SIGNAL TRANSMITTER

(high speed response)

Functions & Features

- Converts DC input from a sensor into a standard process signal
- Isolation between input and output
- 180-microsecond response

Typical Applications

- Isolation for a vibration analyzing system

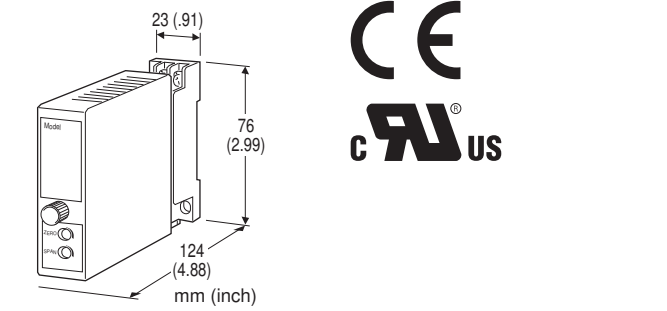

MODEL: M2VF-[1][2]-[3][4]

ORDERING INFORMATION

- Code number: M2VF-[1][2]-[3][4]
- Specify a code from below for each [1] through [4]. (e.g. M2VF-6A-M2/CE/Q)
- Special input and output ranges (For codes Z & 0)
- Specify the specification for option code /Q (e.g. /C01/V01)

[1] INPUT

Current

- A:** 4 - 20 mA DC (Input resistance 250 Ω)
- B:** 2 - 10 mA DC (Input resistance 500 Ω)
- C:** 1 - 5 mA DC (Input resistance 1000 Ω)
- D:** 0 - 20 mA DC (Input resistance 50 Ω)
- E:** 0 - 16 mA DC (Input resistance 62.5 Ω)
- F:** 0 - 10 mA DC (Input resistance 100 Ω)
- G:** 0 - 1 mA DC (Input resistance 1000 Ω)
- H:** 10 - 50 mA DC (Input resistance 100 Ω)
- GW:** -1 - +1 mA DC (Input resistance 1000 Ω)
- FW:** -10 - +10 mA DC (Input resistance 100 Ω)
- Z:** Specify current (See INPUT SPECIFICATIONS)

Voltage

- 3:** 0 - 1 V DC (Input resistance 1 MΩ min.)
- 4:** 0 - 10 V DC (Input resistance 1 MΩ min.)
- 5:** 0 - 5 V DC (Input resistance 1 MΩ min.)
- 6:** 1 - 5 V DC (Input resistance 1 MΩ min.)

4W: -10 - +10 V DC (Input resistance 1 MΩ min.)

5W: -5 - +5 V DC (Input resistance 1 MΩ min.)

0: Specify voltage (See INPUT SPECIFICATIONS)

(Select '/N' for 'Standards & Approvals' code.)

01: Specify voltage (See INPUT SPECIFICATIONS)

(Select '/CE' or '/UL' for 'Standards & Approvals' code.)

[2] OUTPUT

Current

- A:** 4 - 20 mA DC (Load resistance 750 Ω max.)
- B:** 2 - 10 mA DC (Load resistance 1500 Ω max.)
- C:** 1 - 5 mA DC (Load resistance 3000 Ω max.)
- D:** 0 - 20 mA DC (Load resistance 750 Ω max.)
- E:** 0 - 16 mA DC (Load resistance 900 Ω max.)
- F:** 0 - 10 mA DC (Load resistance 1500 Ω max.)
- G:** 0 - 1 mA DC (Load resistance 15 kΩ max.)
- FW:** -10 - +10 mA DC (Load resistance 700 Ω max.)
- GW:** -1 - +1 mA DC (Load resistance 7000 Ω max.)
- Z:** Specify current (See OUTPUT SPECIFICATIONS)

Voltage

- 1:** 0 - 10 mV DC (Load resistance 10 kΩ min.)
- 2:** 0 - 100 mV DC (Load resistance 100 kΩ min.)
- 3:** 0 - 1 V DC (Load resistance 1000 Ω min.)
- 4:** 0 - 10 V DC (Load resistance 10 kΩ min.)
- 5:** 0 - 5 V DC (Load resistance 5000 Ω min.)
- 6:** 1 - 5 V DC (Load resistance 5000 Ω min.)
- 4W:** -10 - +10 V DC (Load resistance 10 kΩ min.)
- 5W:** -5 - +5 V DC (Load resistance 5000 Ω min.)
- 0:** Specify voltage (See OUTPUT SPECIFICATIONS)

[3] POWER INPUT

AC Power

M: 85 - 264 V AC (Operational voltage range 85 - 264 V, 47 - 66 Hz)

(Select '/N' for 'Standards & Approvals' code.)

M2: 100 - 240 V AC (Operational voltage range 85 - 264 V, 47 - 66 Hz)

(90 - 264 V for UL)

DC Power

R: 24 V DC

(Operational voltage range 24 V ±10 %, ripple 10 %p-p max.)

R2: 11 - 27 V DC

(Operational voltage range 11 - 27 V, ripple 10 %p-p max.)

(Select '/N' for 'Standards & Approvals' code.)

P: 110 V DC

(Operational voltage range 85 - 150 V, ripple 10 %p-p max.)

(Select '/N' for 'Standards & Approvals' code.)

[4] OPTIONS (multiple selections)

Standards & Approvals (must be specified)

/N: Without CE or UL

/CE: CE marking

/UL: UL approval, CE marking

Other Options

blank: none

/Q: Option other than the above (specify the specification)
(UL not available)

SPECIFICATIONS OF OPTION: Q (multiple selections)

COATING (For the detail, refer to M-System's web site.)

/C01: Silicone coating

/C02: Polyurethane coating

/C03: Rubber coating

ADJUSTMENT

/V01: Multi-turn fine adjustment

TERMINAL SCREW MATERIAL

/S01: Stainless steel

GENERAL SPECIFICATIONS

Construction: Plug-in

Connection: M3 screw terminals (torque 0.8 N·m)

Screw terminal: Chromated steel (standard) or stainless steel

Housing material: Flame-resistant resin (black)

Isolation: Input to output to power

Overrange output: Approx. -10 to +120 % at 1 - 5 V

Zero adjustment: -5 to +5 % (front)

Span adjustment: 95 to 105 % (front)

INPUT SPECIFICATIONS

■ DC Current:

Shunt resistor attached to the input terminals (0.5 W)

Specify input resistance value for code Z.

■ DC Voltage: -300 - +300 V DC

(-30 - +30 V for the input code 01. Span 60 V max.)

Minimum span: 1 V

Offset: Max. 1.5 times span

Input resistance: $\geq 1 \text{ M}\Omega$

OUTPUT SPECIFICATIONS

■ DC Current: -10 - +20 mA DC

Minimum span: 1 mA

Offset: Max. 1.5 times span

Load resistance: Output drive 15 V max.;

7 V for bidirectional outputs

■ DC Voltage: -10 - +12 V DC

Minimum span: 5 mV

Offset: Max. 1.5 times span

Load resistance: Output drive 1 mA max.; at $\geq 0.5 \text{ V}$

INSTALLATION

Power Consumption

•AC:

Approx. 3 VA at 100 V

Approx. 4 VA at 200 V

Approx. 5 VA at 264 V

•DC: Approx. 3 W

Operating temperature: -5 to +55°C (23 to 131°F)

Operating humidity: 30 to 90 %RH (non-condensing)

Mounting: Surface or DIN rail

Weight: 150 g (0.33 lb)

PERFORMANCE in percentage of span

Accuracy: $\pm 0.1 \%$

Temp. coefficient: $\pm 0.015 \%/^{\circ}\text{C}$ ($\pm 0.008 \%/^{\circ}\text{F}$)

Response time: $\leq 180 \mu\text{sec.}$ (0 - 90 %)

Line voltage effect: $\pm 0.1 \%$ over voltage range

Insulation resistance: $\geq 100 \text{ M}\Omega$ with 500 V DC

Dielectric strength:

1000 V AC @1 minute (input to output)

2000 V AC @1 minute (input or output to power to ground)

STANDARDS & APPROVALS

CE conformity:

EMC Directive (2004/108/EC)

EMI EN 61000-6-4: 2007

EMS EN 61000-6-2: 2005

Low Voltage Directive (2006/95/EC)

EN 61010-1: 2001

Installation Category II

Pollution Degree 2

Input or output to power: Reinforced insulation (300 V)

Input to output: Functional insulation (300 V)

Approval:

UL/C-UL nonincendive Class I, Division 2,

Groups A, B, C, and D

(UL 1604:1994, CAN/CSA-C22.2 No.213:1987)

UL/C-UL general safety requirements

(UL 61010B-1:2003, CAN/CSA-C22.2 No.61010-1:1992)

DIMENSIONS unit: mm (inch)

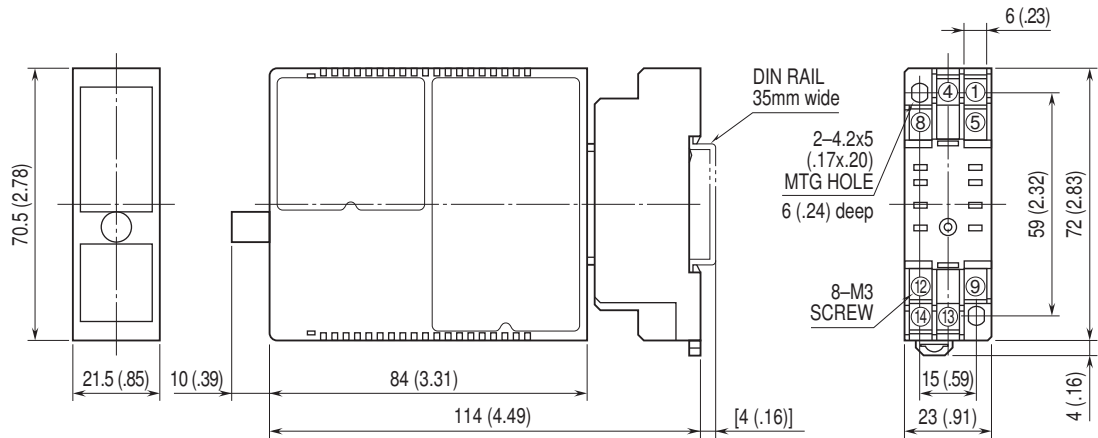

• When mounting, no extra space is needed between units.

TERMINAL ASSIGNMENTS unit: mm (inch)

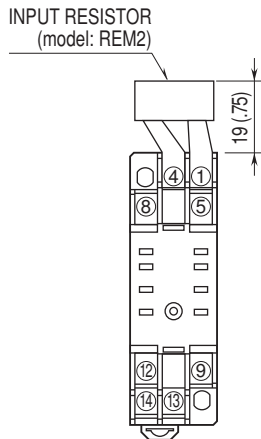

Input shunt resistor attached for current input.

SCHEMATIC CIRCUITRY & CONNECTION DIAGRAM

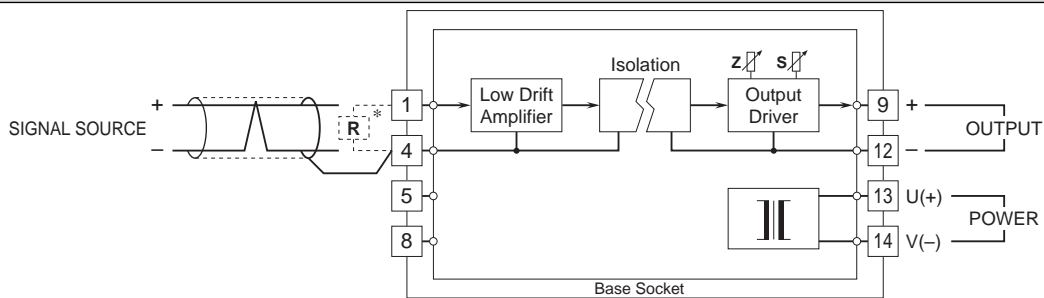

*Input shunt resistor attached for current input.

The M2VF, by its fast-response feature, is not designed to eliminate noise present in the input signal. Use a shielded twisted-pair cable for preventing noise entering through the input wiring.



Specifications are subject to change without notice.