

Super-mini Signal Conditioners Mini-M Series

FREQUENCY TRANSMITTER

(PC programmable)

Functions & Features

- Converts the output from a pulse-type transducer into a standard process signal
- PC programmable
- Sensor excitation
- Direct RS-422 input

Typical Applications

- Positive displacement flowmeters, turbine flowmeters and vortex flowmeters
- Measuring rotation speed of a machine generating dry contact signals

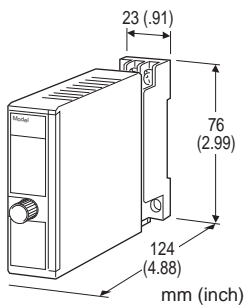

MODEL: M2XPA3-[1][2][3]-[4][5]

ORDERING INFORMATION

- Code number: M2XPA3-[1][2][3]-[4][5]
- Specify a code from below for each [1] through [5].
(e.g. M2XPA3-A14Z1-R/CE/Q)
- Input frequency (e.g. 0 - 10 kHz)
- Output (e.g. 0 - 10 mA)
- Specify the specification for option code /Q
(e.g. /C01/S01)
- Non-specified orders will be shipped at the default factory settings as shown in below. However, a power suffix code must be specified.

If you specify a full code number without specific calibration ranges, the input and output ranges are factory set to the default range.

Use Ordering Information Sheet (No. ESU-5104).

[Factory default setting]

PARAMETER: DEFAULT

Input type: Open collector
Input amplitude: ----
Pulse sensing: DC coupled
Noise filter: None

Detecting level: 2 V
Frequency range: 0 - 200 kHz
Input zero frequency: 0 Hz
Input span frequency: 100 kHz
Linearization: No linearization
Low-end cutout: 0 % (No cutout)
Moving averaging samples: 1
Sensor excitation: 12 V DC / 20 mA
Output type: DC current
Output 0%: 4mA
Output 100%: 20mA

[1] INPUT

A1: Open collector

A2: Mechanical contact

B: Voltage pulse

G: Two-wire current pulse

J: RS-422 line driver pulse

Configurator software is used to change the frequency range. The input type can be switched to other than the one of the selected suffix code by selecting the input type selectors inside the unit before software adjustment.

[2] EXCITATION

2: 4 V DC / 20 mA

3: 8 V DC / 20 mA

4: 12 V DC / 20 mA

Configurator software is used to change the excitation value.

[3] OUTPUT

Current

Z1: Range 0 - 20 mA DC

Voltage

V1: Range -2.5 - +2.5 V DC

V2: Range -10 - +10 V DC

(Configurator software is used to adjust the output range and to change the output over the described range of the selected suffix code.)

[4] POWER INPUT

AC Power

M2: 100 - 240 V AC (Operational voltage range 85 - 264 V, 47 - 66 Hz)

(90 - 264 V for UL)

DC Power

R: 24 V DC

(Operational voltage range 24 V \pm 10 %, ripple 10 %p-p max.)

P: 110 V DC

(Operational voltage range 85 - 150 V, ripple 10 %p-p max.)

(110 V \pm 10 % for UL)

[5] OPTIONS (multiple selections)

Standards & Approvals (must be specified)

/N: Without CE or UL

/CE: CE marking

/UL: UL approval, CE marking

Other Options

blank: none

/Q: Option other than the above (specify the specification)
(UL not available)

SPECIFICATIONS OF OPTION: Q (multiple selections)

COATING (For the detail, refer to M-System's web site.)

/C01: Silicone coating

/C02: Polyurethane coating

/C03: Rubber coating

TERMINAL SCREW MATERIAL

/S01: Stainless steel

RELATED PRODUCTS

- JX configurator connection kit (model: JXCON)

GENERAL SPECIFICATIONS

Construction: Plug-in

Connection: M3 screw terminals (torque 0.8 N·m)

Housing material: Flame-resistant resin (black)

Isolation: Input to output to power

Overrange output: Approx. -15 to +115 % at 1 - 5 V

Zero adjustment: -5 to +5 % (front)

Span adjustment: 95 to 105 % (front)

Configuration: Via PC Configurator Software (model: JXCON)
on the Windows PC connected to the front jack.

Programmable features include:

- I/O type and range
- Detecting level
- Sensor excitation
- Zero and span adjustments
- Low-end cutout
- Linearization
- Sample number for the moving average

DIP switch settings:

- Input Type
- Pulse Sensing (Capacitor coupled, DC coupled)
- Noise Filter (High, Low, None)

Status indicator LED: Blinking patterns indicate different operating status of the transmitter.

Excitation adjustment: 4 V, 8 V or 12 V DC

Configurator connection: 2.5 dia. miniature jack;
RS-232-C level

Low-end cutout: 0 - 115 % programmable;

No cutout with 0 % setting; hysteresis fixed at 1 % (factory set to: No cutout)

INPUT SPECIFICATIONS

Excitation: Shortcircuit protection; 30 mA max. at shortcircuit

Frequency ranges:

0 - 10 mHz, 0 - 100 mHz, 0 - 1 Hz, 0 - 10 Hz, 0 - 100 Hz,
0 - 1 kHz, 0 - 10 kHz, 0 - 200 kHz
(up to 10 Hz for mechanical contact)

Minimum pulse width time requirement: 2.5 μ sec. for both ON and OFF. (50 msec. for mechanical contact)

Minimum span: 10 % of the selected frequency range
(5 % of the selected frequency range when the range is
0 - 200 kHz.)

Noise filter: See table 2

Choose the noise filter type appropriate for the selected frequency range to ensure the described accuracy.

■ Open Collector & Mechanical Contact

Input requirements

EXC	SENSING	OFF	ON
4V	Approx. 3V/0.7mA	$\geq 2k\Omega/1V$	$\leq 200\Omega/0.2V$
8V	Approx. 6V/1.5mA	$\geq 4k\Omega/3V$	$\leq 600\Omega/1V$
12V	Approx. 9V/2.3mA	$\geq 2k\Omega/3V$	$\leq 400\Omega/1V$

Detecting level:

0.6 V (4 V excitation)

2 V (8 V / 12 V excitation)

If not specified, the input range is shown below.

A1 Open collector: 0 - 100 kHz

A2 Mechanical contact: 0 - 10 Hz

■ Voltage Pulse

Waveform: Square or sine

Input impedance: $\geq 10 k\Omega$

Input amplitude: Min. 0.1 Vp-p, max. 100 Vp-p

Max. voltage between input terminals: See table 1.

Detecting levels: -2 - +4 V (internal detecting voltage)

If not specified, the input range is 0 - 100 kHz.

■ Two-wire Current Pulse

Input resistance: Receiving resistor 100 Ω

Input range: 0 - 25 mA

Input amplitude: Min. 10 mAp-p, max. 25 mAp-p

Detecting levels: -2 - +4 V (internal detecting voltage)

If not specified, the input range is 0 - 100 kHz.

■ RS-422 Line Driver Pulse

Receiver: Conforms to RS-422

If not specified, the input range is 0 - 100 kHz.

VOLTAGE PULSE

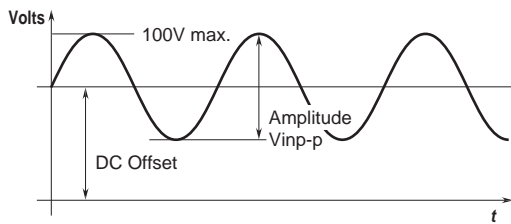

[Table 1]

PULSE AMPLITUDE	MAX. VOLTAGE AT INPUT TERMINALS	SENSITIVITY SCALE
50 – 100 Vp-p	100 V*	1/20
25 – 50 Vp-p	50 V	1/10
10 – 25 Vp-p	25 V	1/5
5 – 10 Vp-p	10 V	1/2
1 – 5 Vp-p	5 V	1
0.5 – 1 Vp-p	1 V	5
0.1 – 0.5 Vp-p**	0.5 V	10
Open collector Mechanical contact 2-wire current pulse	----	1

*Limited to $\leq 70V$ for CE conformance or UL approval.

**Input frequency ≤ 50 kHz

A specific sensitivity scale is applied according to the pulse amplitude by setting up the DIP switch and PC Configurator Software (model: JXCON). The scaled input voltage is then compared to the detecting level at -2.00 through +4.00V. With DC coupling, the scaled maximum input voltage level must be higher than and the scaled minimum input voltage level must be lower than the detecting level so that the pulse state is accurately detected.

[Table 2]

FREQUENCY RANGE	NOISE FILTER
0 – 10 mHz	High
0 – 100 mHz	High
0 – 1 Hz	Low
0 – 10 Hz	Low
0 – 100 Hz	Low
0 – 1 kHz	Low
0 – 10 kHz	None
0 – 200 kHz	None

Choose the noise filter type appropriate for the selected frequency range to ensure the described accuracy.

OUTPUT SPECIFICATIONS

DC Current

Output range: 0 – 20 mA DC

Conformance range: 0 – 24 mA DC

Minimum span: 1 mA

Offset: Lower range can be any specific value within the output range provided that the minimum span is maintained.

Load resistance: Output drive 12 V max.

(e.g. 4 – 20 mA: 600 Ω [12 V / 20 mA])

If not specified, the output range is 4 – 20 mA DC.

DC Voltage

Code V1 (narrow spans)

Conformance range: -3 – +3 V DC

Output range: -2.5 – +2.5 V DC

Minimum span: 250 mV

Code V2 (wide spans)

Conformance range: -11.5 – +11.5 V DC

Output range: -10 – +10 V DC

Minimum span: 1 V

Offset: Lower range can be any specific value within the output range provided that the minimum span is maintained.

Load resistance: Output drive 1 mA max.

(e.g. 1 – 5 V: 5000 Ω [5 V / 1 mA])

If not specified, the output range is shown below.

V1: 0 – 1 V DC

V2: 1 – 5 V DC

INSTALLATION

Power Consumption

•AC:

Approx. 4 VA at 100 V

Approx. 5 VA at 200 V

Approx. 6 VA at 264 V

•DC: Approx. 2 W

Operating temperature: -5 to +55°C (23 to 131°F)

Operating humidity: 30 to 90 %RH (non-condensing)

Mounting: Surface or DIN rail

Weight: 150 g (0.33 lb)

PERFORMANCE

Accuracy: Input accuracy + output accuracy

Inversely proportional to the span.

Input accuracy: ± 0.03 % of the selected freq. range

(The input span 100 kHz is used for calculation with 0 – 200 kHz range. The input accuracy is fixed at ± 0.03 % when [Frequency range / Input span] equals 1 or less.)

Output accuracy: ± 0.03 % of the selected output range

See CALCULATION EXAMPLES OF OVERALL ACCURACY.

Temp. coefficient: ± 0.015 %/°C (± 0.008 %/°F) of I/O range at -5 to +55°C [23 to 131°F]

Response time: 0.5 sec. + 1 pulse cycle (0 – 90 %)

Line voltage effect: ± 0.1 % over voltage range

Insulation resistance: ≥ 100 M Ω with 500 V DC

Dielectric strength: 2000 V AC @1 minute (input to output to power to ground)

CALCULATION EXAMPLES OF OVERALL ACCURACY

[Example] Open collector input, 0 – 50 kHz; 1 – 5 V output.

Selected freq. range (100 kHz) \div Input span (50 kHz) \times

Accuracy (0.03 %) = 0.06 % (Input accuracy)

Selected output range (20 V) \div Output span (4 V) \times

Accuracy (0.03 %) = 0.15 % (Output accuracy)

Overall accuracy = 0.06 + 0.15 = ±0.21 %

STANDARDS & APPROVALS

CE conformity:

EMC Directive (2004/108/EC)

EMI EN 61000-6-4: 2007

EMS EN 61000-6-2: 2005

Low Voltage Directive (2006/95/EC)

EN 61010-1: 2001

Installation Category II

Pollution Degree 2

Input or output to power: Reinforced insulation (300 V)

Input to output: Basic insulation (300 V)

Approval:

UL/C-UL nonincendive Class I, Division 2,

Groups A, B, C, and D

(ANSI/ISA-12.12.01:2007, CAN/CSA-C22.2 No.213:1987)

UL/C-UL general safety requirements

(UL 61010-1:2008, CAN/CSA-C22.2 No.61010-1:1992)

EXTERNAL VIEW

FRONT VIEW (with cover open)

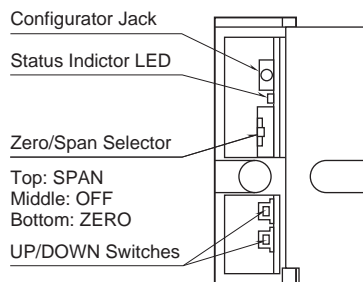

The front cover cannot be opened to 180 deg. when flush with neighboring units.

LEFT SIDE VIEW (with cover removed)

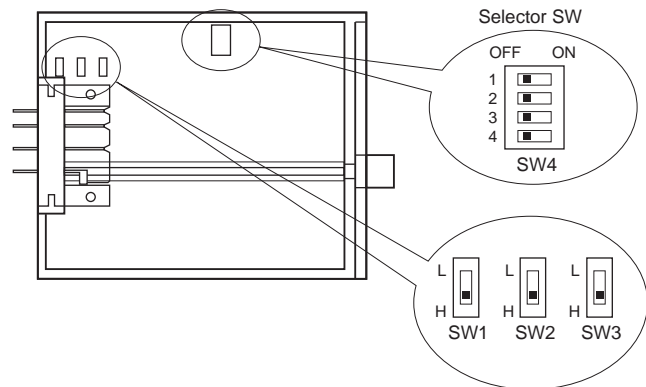

Refer to the instruction manual for detailed procedures.

DIMENSIONS unit: mm (inch)

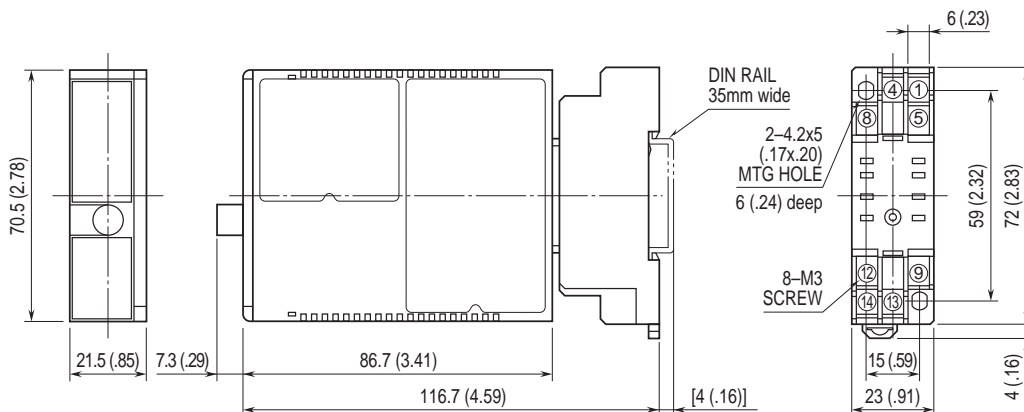

• When mounting, no extra space is needed between units.

SCHEMATIC CIRCUITRY & CONNECTION DIAGRAM

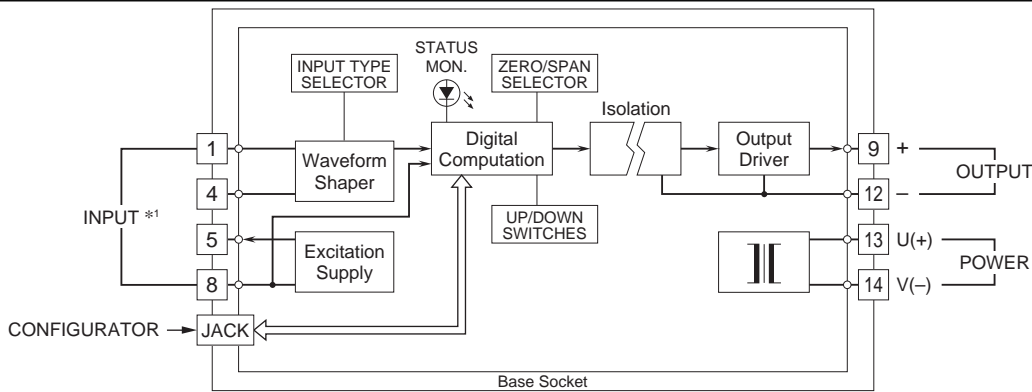

*1. Input Connection Examples

■ Open Collector or Mechanical Contact

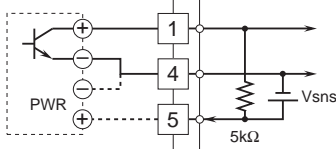

■ Voltage Pulse

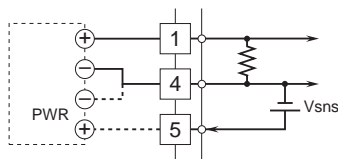

■ RS-422 Line Driver Pulse

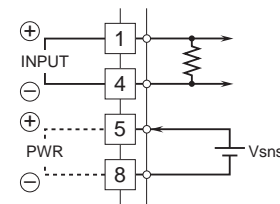

■ 2-Wire Current Pulse

• Built-in Excitation

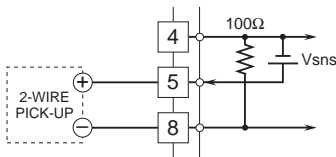

• External DC Supply

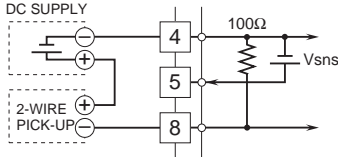

EXPLANATIONS OF TERMS

Low-end cutout:

The function where the output signal is forced to 0% below the setpoint input. Hysteresis is fixed at 1%.

[Example] Input zero frequency 0 Hz

Input span frequency 1 kHz

Low-end cutout 10 %

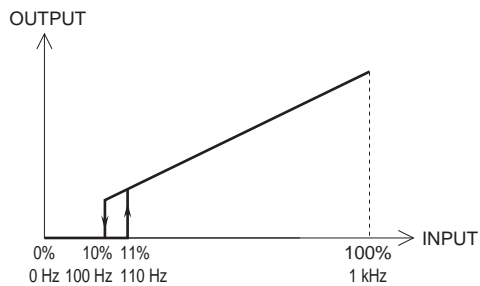

Specifications are subject to change without notice.