

Super-mini Signal Conditioners Mini-M Series

ENCODER SPEED TRANSMITTER

(PC programmable; built-in excitation)

Functions & Features

- Converts a two-phase forward and reverse rotation pulse signal with 90 degree phase difference into a forward and reverse speed signal
- Built-in excitation
- PC programmable input and output ranges
- Input pulse monitoring LED
- Direct RS-422 input
- CE marking
- UL approval

Typical Applications

- Measuring moving speed of a machine with a rotary encoder

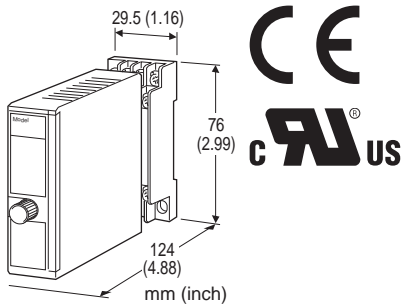

MODEL: M2XRP2-[1][2][3]-[4][5]

ORDERING INFORMATION

- Code number: M2XRP2-[1][2][3]-[4][5]
Specify a code from below for each [1] through [5].
(e.g. M2XRP2-000-M2/CE/Q)
 - Specify the specification for option code /Q
(e.g. /C01/S01)
 - Non-specified orders will be shipped at default factory settings (M2XRP2-000: Open collector input/12 V excitation/4 - 20 mA output). However, a power suffix code must be specified.
- If you specify a full code number without specific calibration ranges, the input frequency is factory set to the maximum range available for the selected input code and the output is set to the default range. Use Ordering Information Sheet (No. ESU-5059).
- Note: Must be used with its socket. NOT installable to a multi-unit installation base. (e.g. model: M2BS-16)

[1] INPUT

0: User-calibrated (Factory default: open collector, 0 - 100 kHz)

If the unit is to be factory-calibrated to a specific input type, please select from the following:

- A: Open collector
- B: Voltage pulse
- J: RS-422 line driver pulse

[2] EXCITATION

0: User-calibrated (Factory default: 12 V DC / 5 mA)

If the unit is to be factory-calibrated to a specific voltage value, please select from the following:

- 1: 5 V DC / 5 mA
- 4: 12 V DC / 5 mA

[3] OUTPUT

0: User-calibrated (Factory default: 4 - 20 mA)

If the unit is to be factory-calibrated to a specific output type, please select from the following:

Current

Z1: Range 0 - 20 mA DC

Voltage

V1: Range -2.5 - +2.5 V DC

V2: Range -10 - +10 V DC

(Configurator software is used to change output over the described range of the selected suffix code. For changing out of this range, set the Output Range Selectors inside the unit before software adjustment.)

[4] POWER INPUT

AC Power

M2: 100 - 240 V AC (Operational voltage range 85 - 264 V, 47 - 66 Hz)
(90 - 264 V for UL)

DC Power

R: 24 V DC
(Operational voltage range 24 V \pm 10 %, ripple 10 %p-p max.)
P: 110 V DC
(Operational voltage range 85 - 150 V, ripple 10 %p-p max.)
(110 V \pm 10 % for UL)

[5] OPTIONS (multiple selections)

Standards & Approvals (must be specified)

- /N: Without CE or UL
- /CE: CE marking
- /UL: UL approval, CE marking

Other Options

blank: none

/Q: Option other than the above (specify the specification)
(UL not available)

SPECIFICATIONS OF OPTION: Q (multiple selections)

COATING (For the detail, refer to M-System's web site.)

/C01: Silicone coating

/C02: Polyurethane coating

/C03: Rubber coating

TERMINAL SCREW MATERIAL

/S01: Stainless steel

RELATED PRODUCTS

- JX configurator connection kit (model: JXCON)

GENERAL SPECIFICATIONS

Construction: Plug-in

Connection: M3 screw terminals (torque 0.8 N·m)

Housing material: Flame-resistant resin (black)

Isolation: Input to output to power

Overrange output: Approx. -15 to +115 % at 1 - 5 V

Zero adjustment: -5 to +5 % (front)

Span adjustment: 95 to 105 % (front)

Configuration: Via PC Configurator Software (model:JXCON)

on the Windows PC connected to
the front jack.

Programmable features include:

- I/O type and range
- Zero and span adjustments
- Low-end cutout
- Linearization

Status indicator LED: Red LED; Flashing patterns indicate
different operating status of the transmitter.

Input monitor (PL1): Green LED blinks according to the input
phase A.

Input monitor (PL2): Green LED blinks according to the input
phase B.

Excitation adjustment: 5V or 12V DC

Configurator connection: 2.5 dia. miniature jack;
RS-232-C level

Pulse sensing: DC coupled or capacitor coupled selectable
with DIP SW

Low-end cutout: 100 msec. - 100 sec. or no cutout
programmable

INPUT SPECIFICATIONS

Excitation: Shortcircuit protection; 20 mA max. at
shortcircuit

Maximum frequency: 200 kHz

Frequency ranges:

0 - 10 mHz, 0 - 100 mHz, 0 - 1 Hz, 0 - 10 Hz, 0 - 100 Hz,
0 - 1 kHz, 0 - 10 kHz, 0 - 100 kHz

(Choose 100 kHz range to set the zero/span frequencies
lower than -100 kHz (higher than 100 kHz in the reverse
direction) or higher than 100 kHz (higher than 100 kHz in
the forward direction.))

Minimum pulse width time requirement: 2.5 μ sec.

Minimum span: 10 % of the selected frequency range

Noise filter: See table 2

■ **Open Collector**

Input requirements

EXCITATION	SENSING	OFF	ON
5 V	Approx. 5 V	≥ 200 k Ω	≤ 200 Ω
12 V	Approx. 10 V	≥ 200 k Ω	≤ 200 Ω

Amplitude: 5 - 12 V

Detecting level:

5 V excitation: 1 V

12 V excitation: 2 V

(Detecting voltage in the internal circuit.

For open collector input, be sure to re-adjust the voltage
back to 1 V (5 V excitation) or 2 V (12 V excitation) if it has
been changed for other input types.)

Detecting pulse edge: OFF to ON

If not specified, the input range is 0 Hz - 1 kHz.

■ **Voltage Pulse**

Waveform: Square or sine

Input impedance: 10 k Ω min.

Pulse amplitude: 0.1 - 30 Vp-p

Pulse amplitude Range: See table 1.

Max. voltage between input terminals: See table 1.

Sensitivity Scale: See table 1.

Detecting level: -2 - +4 V

Detecting pulse state: A pulse rise detected when the input
voltage goes above the detecting level;
a pulse sink detected when it goes below the level.

If not specified, the input range is 0 Hz - 1 kHz.

■ **RS-422 Line Driver Pulse**

Receiver: Conforms to RS-422

If not specified, the input range is 0 Hz - 1 kHz.

[Table 1]

PULSE AMPLITUDE RANGE	MAX.INPUT VOLTAGE	SENSITIVITY SCALE
10 - 30 Vp-p	30 V	1/6
5 - 10 Vp-p	10 V	1/2
1 - 5 Vp-p	5 V	1
0.1 - 1 Vp-p*	1 V	5

*Input frequency within ± 50 kHz

When the parameters have been set with DIP switches and the
PC Configurator Software (model: JXCON), a specific sensitivity
scale is applied according to the pulse amplitude setting. The
scaled input voltage is then compared to the preset detecting
level (-2.00 to +4.00 V).

With DC coupling, the scaled maximum voltage must be higher
than the detecting level and the minimum voltage must be lower
than that so that the pulse state is accurately detected. (Refer to
the instruction manual for detailed information about adjusting the
detecting level.)

[Table 2]

FREQUENCY RANGE	NOISE FILTER TYPE
0 – 10 mHz	With
0 – 100 mHz	With
0 – 1 Hz	With
0 – 10 Hz	W/O
0 – 100 Hz	W/O
0 – 1 kHz	W/O
0 – 10 kHz	W/O
0 – 100 kHz	W/O

Be sure to apply the noise filter appropriate for the selected frequency range as shown in the table above. The accuracy may not be assured if no filter is applied.

OUTPUT SPECIFICATIONS

■ DC Current

Output range: 0 – 20 mA DC

Conformance range: 0 – 23mA DC

Minimum span: 1 mA

Offset: Lower range can be any specific value within the output range provided that the minimum span is maintained.

Load resistance: Output drive 12 V max.
(e.g. 4 – 20 mA: 600 Ω [12 V / 20 mA])

If not specified, the output range is 4 – 20 mA DC.

■ DC Voltage

Code V1 (narrow spans)

Conformance range: -3 – +3 V DC

Output range: -2.5 – +2.5 V DC

Minimum span: 250 mV

Code V2 (wide spans)

Conformance range: -11.5 – +11.5 V DC

Output range: -10 – +10 V DC

Minimum span: 1 V

Offset: Lower range can be any specific value within the output range provided that the minimum span is maintained.

Load resistance: Output drive 1 mA max.
(e.g. 1 – 5 V: 5000 Ω [5 V / 1 mA])

If not specified, the output range is shown below.

V1: 0 – 1 V DC

V2: 1 – 5 V DC

INSTALLATION

Power Consumption

•AC Power input:

Approx. 4 VA at 100 V

Approx. 5 VA at 200 V

Approx. 6 VA at 264 V

•DC power input: Approx. 3 W

Operating temperature: -5 to +55°C (23 to 131°F)

Operating humidity: 30 to 90 %RH (non-condensing)

Mounting: Surface or DIN rail

Weight: 150 g (0.33 lbs)

PERFORMANCE

Accuracy: Input accuracy + output accuracy

Input accuracy: ≤ ±0.03% of the selected freq. range

Output accuracy: ≤ ±0.03% of the selected output range

The input accuracy is inversely proportional to the input span; while the output accuracy is likewise inversely proportional to the output span. With [Input Range / Input Span] ≤ 1, the input accuracy is fixed at ±0.03%.

See CALCULATION EXAMPLES OF OVERALL ACCURACY.

Temp. coefficient: ±0.015 %/°C (±0.008 %/°F) of I/O range at -5 to +55°C [23 to 131°F]

Response time: 0.5 sec. + 1 pulse cycle (0 – 90 %)

Line voltage effect: ±0.1 % over voltage range

Insulation resistance: ≥ 100 MΩ with 500 V DC

Dielectric strength: 2000 V AC @1 minute (input to output to power to ground)

CALCULATION EXAMPLES OF OVERALL ACCURACY

[Example] Open collector input, 0 – 50 kHz; 1 – 5 V output.

Selected freq. range (100 kHz) ÷ Input span (50 kHz) ×

Accuracy (0.03 %) = 0.06 % (Input accuracy)

Selected output range (20 V) ÷ Output span (4 V) ×

Accuracy (0.03 %) = 0.15 % (Output accuracy)

Overall accuracy = 0.06 + 0.15 = ±0.21 %

STANDARDS & APPROVALS

CE conformity:

EMC Directive (2004/108/EC)

EMI EN 61000-6-4: 2007

EMS EN 61000-6-2: 2005

Low Voltage Directive (2006/95/EC)

EN 61010-1: 2001

Installation Category II

Pollution Degree 2

Input or output to power: Reinforced insulation (300 V)

Input to output: Basic insulation (300 V)

Approval:

UL/C-UL nonincendive Class I, Division 2,

Groups A, B, C, and D hazardous locations

(ANSI/ISA-12.12.01:2007, CAN/CSA-C22.2 No.213:1987)

UL/C-UL general safety requirements

(UL 61010B-1:2003, CAN/CSA-C22.2 No.61010-1:1992)

EXTERNAL VIEW

FRONT VIEW (with cover open)

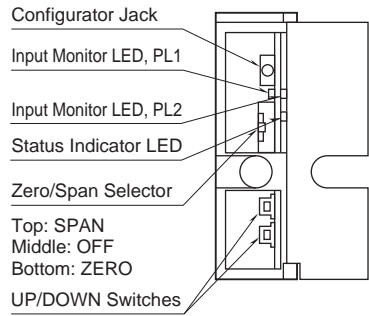

The front cover cannot be opened to 180 deg. when flush with neighboring units.

LEFT SIDE VIEW (with cover removed)

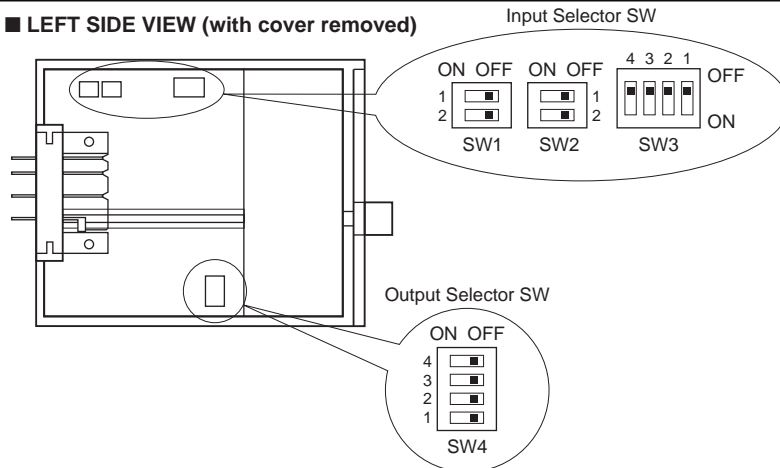

Refer to the instruction manual for detailed procedures.

OPERATION

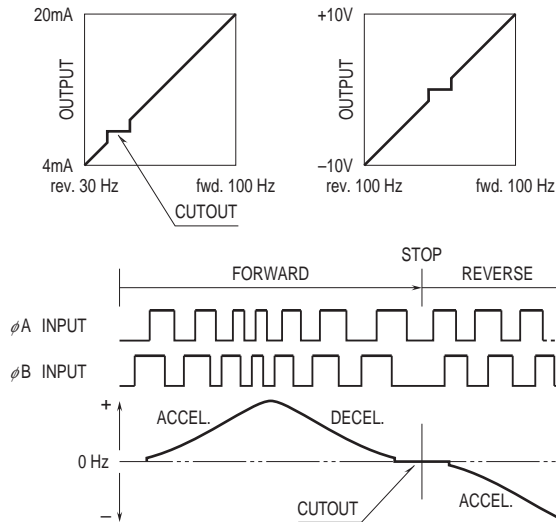

Forward Rotation: Phase A leads the Phase B by 90 degrees.
Reverse Rotation: Phase A lags behind Phase B by 90 degrees.

EXTERNAL DIMENSIONS & TERMINAL ASSIGNMENTS unit: mm (inch)

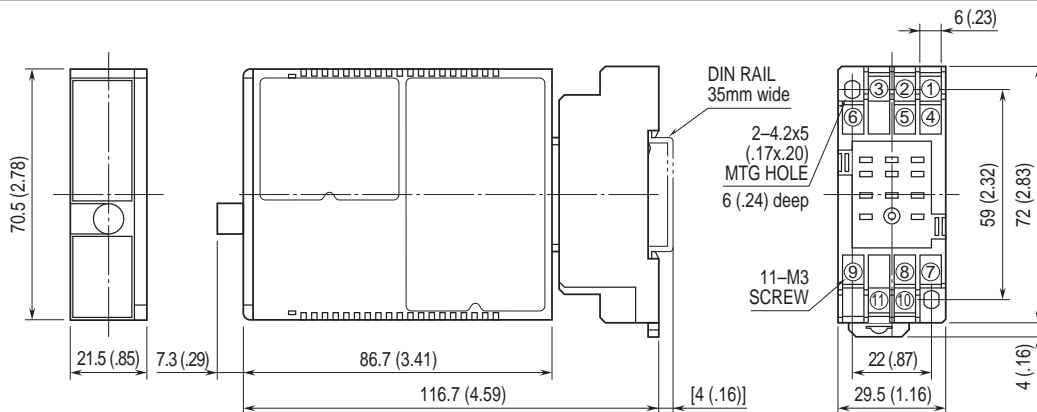

• When mounting, no extra space is needed between units.

SCHEMATIC CIRCUITRY & CONNECTION DIAGRAM

■ OPEN COLLECTOR, VOLTAGE INPUT

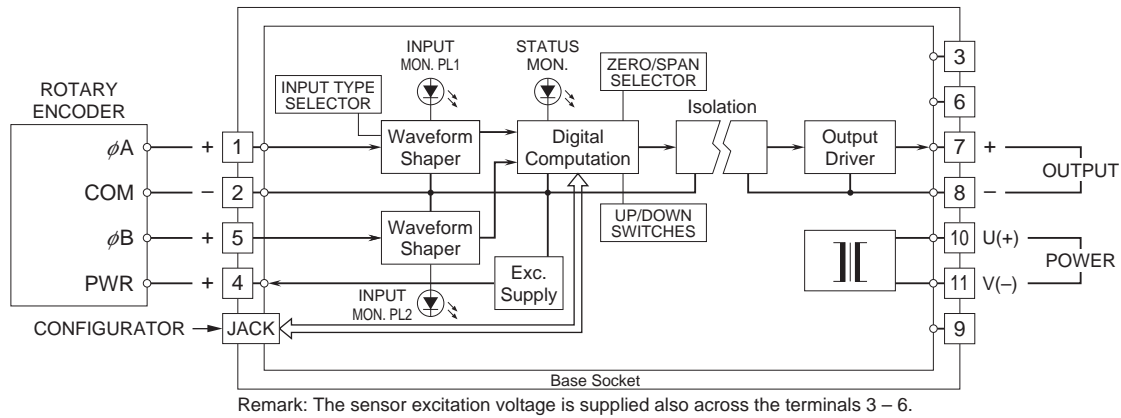

■ RS-422 LINE DRIVER INPUT

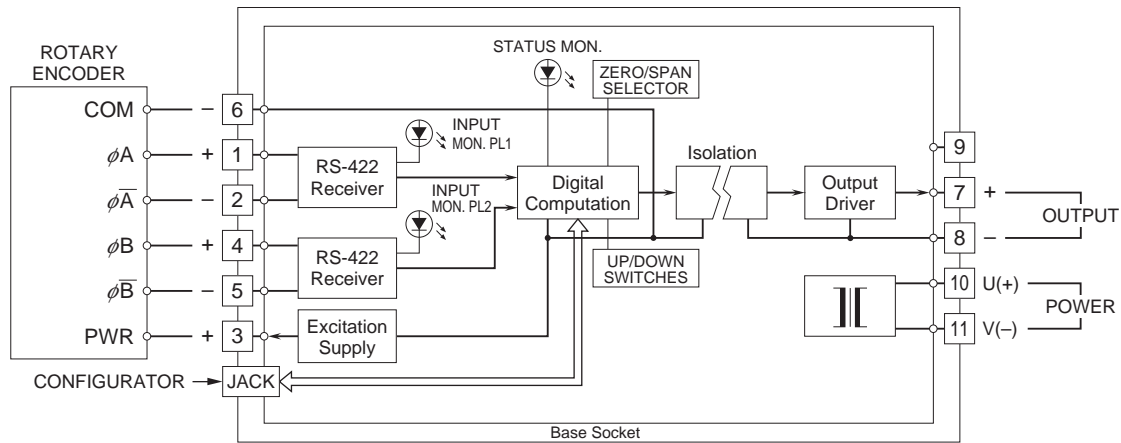

Specifications are subject to change without notice.