

SS Series Locking Wall Mounts

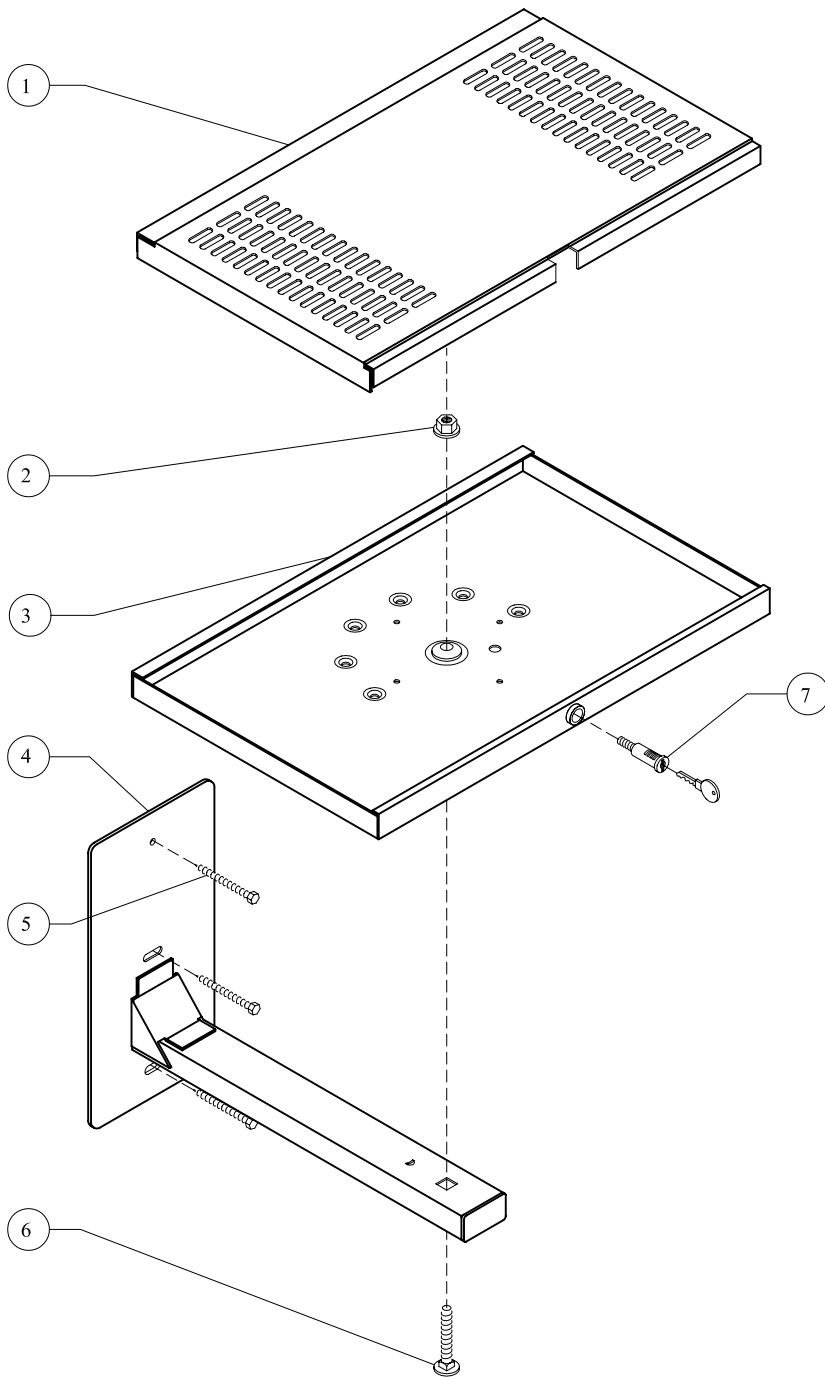

1. Locate centerline of wood wall stud. Use backplate of mounting arm (#4) as template to determine location of holes. Drill pilot holes (the minor diameter of the screws) into center of wall stud. Attach mounting arm to center of stud using wood screws provided (#5). Verify sufficient arm-to-ceiling clearance for monitor before installation. Test holding action of installation before mounting monitor.
2. Place lower plate (#3) on mounting arm, aligning hole in middle of plate with hole in mounting arm.
3. Insert carriage bolt (#6) through bottom of mounting arm and lower plate.
4. Place whiz nut (#2) on carriage bolt.
5. Turn lower plate until protrusion on mounting arm slips into one of the four holes in the swivel plate on the underside of the lower plate.
6. Tighten whiz nut.
7. Invert monitor. Position inverted upper plate (#1) on bottom of monitor with lock slot facing front of monitor. Attach monitor to upper plate with fasteners appropriate to the underside of the monitor.
8. Turn monitor right side up. Place upper plate on lower plate, guiding rear of upper plate beneath lip at back of lower plate. Slip upper plate into lower plate and pull forward until front of upper plate meets front of lower plate.
9. Place key in lock (#7) and insert lock in lock retainer. Turn key clockwise until lock is completely screwed into lock retainer, then turn key back (counterclockwise) until key is vertical. Remove key.