



EasySync Ltd

**USB2-H-5002 Hi-Speed USB to 2-Port
RS485 Adapter
Data Sheet**

Document Reference No.: ES_000020

Version 1.2

Issue Date: 2010-01-25

The USB-COM-Plus adaptors are a family of communication devices from EasySync Ltd. This model, USB2-H-5002, provides a simple method of adapting legacy serial devices with RS485 interfaces to modern USB ports by incorporating the FTDI FT2232H Hi-Speed USB bridge chip.

A power supply output of +5VDC @ up to 250mA is available on the 9-pin D-sub connectors. Indicator LEDs provide functional status.

EasySync Ltd

Unit 1, 2 Seaward Place, Centurion Business Park, Glasgow, G41 1HH, United Kingdom

Tel.: +44 (0) 141 418 0181 Fax: + 44 (0) 141 418 0110

E-Mail (Support): support@easysync.co.uk Web: <http://www.easysync.co.uk>

Neither the whole nor any part of the information contained in, or the product described in this manual, may be adapted or reproduced in any material or electronic form without the prior written consent of the copyright holder. This product and its documentation are supplied on an as-is basis and no warranty as to their suitability for any particular purpose is either made or implied. EasySync Ltd will not accept any claim for damages howsoever arising as a result of use or failure of this product. Your statutory rights are not affected. This product or any variant of it is not intended for use in any medical appliance, device or system in which the failure of the product might reasonably be expected to result in personal injury. This document provides preliminary information that may be subject to change without notice. No freedom to use patents or other intellectual property rights is implied by the publication of this document. EasySync Ltd, Unit 1, 2 Seaward Place, Centurion Business Park, Glasgow, G41 1HH, United Kingdom. Scotland Registered Number: SC224924

1	Introduction	4
1.1	Functional Description	4
1.2	LED Description.....	6
1.3	Block Diagram.....	6
1.3.1	Block description	6
1.4	Features.....	7
1.5	Performance Figures	8
1.6	Ordering Information.....	8
2	Installation.....	9
2.1	Example Applications and Configurations	9
2.2	Hardware Installation	9
2.2.1	Mounting.....	9
2.2.2	Wiring.....	10
2.3	Device Driver Installation	11
2.3.1	Microsoft Windows.....	11
2.3.2	Mac OS X, Linux, Windows CE.....	15
3	Connections.....	16
3.1	External Connectors	16
3.1.1	USB.....	16
3.1.2	RS485.....	17
4	Electrical details	18
4.1	USB	18
4.2	RS485	19
4.3	Power Output.....	19
5	Mechanical Details.....	20
5.1	Module Mechanical Dimensions.....	20
5.2	UniClip™ Mechanical Dimensions	21
6	Physical Environment Details	22
6.1	Storage	22
6.2	Operating.....	22
7	Environmental Approvals & Declarations.....	23
7.1	EMI Compatibility.....	23
7.2	Safety	23
7.3	Environmental.....	23
7.4	Reliability.....	23

7.4.1	MTTF	23
7.5	Import / Export Information.....	24
8	Troubleshooting	25
8.1	Hardware	25
8.2	Device Driver	25
8.3	Technical Support	26
9	Contact Information	27
Appendix A - List of Figures and Tables		28
Appendix B - Revision History		29

1 Introduction

1.1 Functional Description

The USB-COM-Plus adaptors are a family of communication devices. This model, is a USB to a dual interface RS485 level serial UART adaptor incorporating FTDI's FT2232H Hi-Speed USB2.0 (480Mb/s) to dual serial UART interface IC device. The FT2232H handles all the USB signaling and protocols. The adaptor provides a fast, simple way to connect devices with an RS485 interface to USB.

USB2-H-5002 is a USB to a dual-port RS485 adapter.

The integrated electronics of the USB2-H-5002 utilise the FTDI FT2232H and includes RS485 level shifters plus TXD/RXD LEDs to provide a visual indication of data traffic through the adapter.



Figure 1.1 USB2-H-5002

Flexible mounting allows the USB2-H-5002 to be used in a variety of applications, from a portable adapter to accompany a laptop to permanent installations in industrial, commercial and retail locations.

The enclosure incorporates a standard USB-Mini-B client connector for connection to an upstream host or hub port. RS485-level signals are available on two industry-standard DE-9P connectors. The maximum RS485-level data rate is 10Mbps.

The USB2-H-5002 adapter require USB device drivers, available free from <http://www.easysync.co.uk> or <http://www.easysync-ltd.com>, which are used to make the USB2-H-5002 appear as a Virtual COM Port (VCP). This allows existing serial communications software, such as HyperTerminal, to exchange data through the USB2-H-5002 to a legacy RS485 peripheral device.

Pin 9 of the D-sub connector can provide +5V power output with maximum 250mA.

1.2 LED Description

The USB2-H-5002 uses 5 LEDs to indicate a valid link as well as data traffic according to the following table:

LED Color	Function	Description	quantity
Yellow	Enumerated	ON when USB2-H-5002 is configured and ready	1
Red	TxD Activity	Flashes when data is transmitted from the USB2-H-5002 to the attached RS485 device	2
Green	RxD Activity	Flashes when data is transmitted from the attached RS485 device to the USB2-H-5002	2

Table 1.1 – LED Description

1.3 Block Diagram

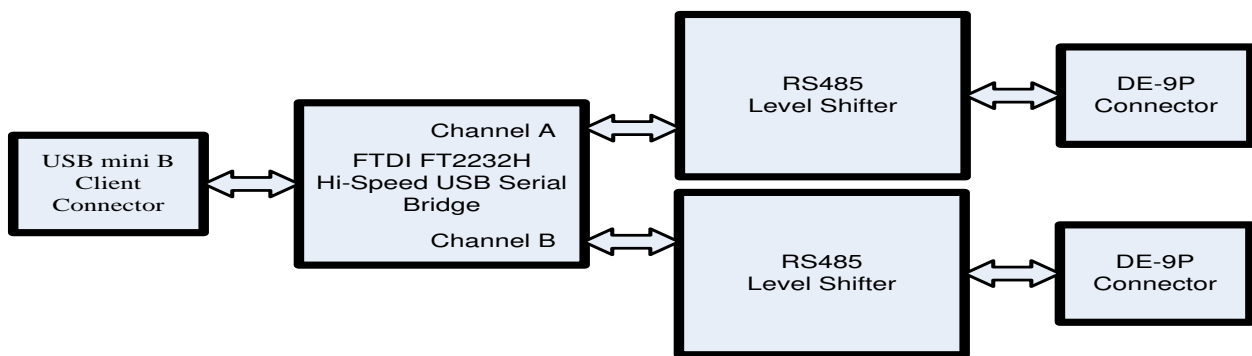

Figure 1.2 USB2-H-5002 Block Diagram

1.3.1 Block description

USB mini B Client Connector

This connector provides the interface for connection to a USB Host or Hub port. A standard “A to mini B” cable is provided, though one of a different length may also be used. The maximum cable length is 5 meters, according to the USB 2.0 specification.

FTDI FT2232H

FT2232H Hi-Speed USB2.0 (480Mb/s) is a dual serial UART interface IC device. Operating system device drivers are required in order to work with the FT2232H to provide the Virtual COM Port serial functionality.

Dual RS485 Level Shifter

The RS485 level shifter converts the signals provided by the FT2232H into the voltage levels required by RS485 devices.

DE-9P Connector (Male)

The DE-9P connector is configured in an industry standard (TIA/EIA-485) pin-out to provide connection to RS485 peripherals through standard cables. See section 3.1.2

1.4 Features

- Adds dual RS-485 serial port by connecting to a USB 2.0 Hi-Speed interface.
- Echo and non-Echo modes selection.
- Easy plug & play installation and RS-485 device connection
- Works with USB 1.1 & 2.0 Host and Hub ports
- Industry Standard FTDI chip set & device drivers for maximum compatibility
- Microsoft Windows® WHQL-certified, Mac OS X, Linux and Windows CE device drivers
- Installs as a standard Windows COM port
- COM port number can be changed to any available COM port number, to support HyperTerminal, or any other serial communications software application running in Windows
- Supports Windows Server 2008, 2003, Vista, XP, 2000, Linux, Mac OS X
- FIFO: 4k byte transmit buffer, 4k byte receive buffer
- RS-485 data signals: Data+, Data-, GND
- Powered by USB port. No external power adapter required.
- Pin 9 of DE-9P can provide +5VDC output at 250mA (total on 2 ports)
- Serial port speed up to 10Mbps
- Serial Communication Parameters
 - Parity: None, Even, Odd
 - Data bits: 7, 8
 - Flow control: X-ON/X-OFF, None
- Dual DE-9P male connector
- LEDs indicate USB Enumeration, RxD, TxD for monitoring port status & easy diagnostics
- Operating temperature of -40°C to +85°C
- USB cable of 0.9 meter included
- FCC and CE approved.

1.5 Performance Figures

Parameter	Performance
USB Interface	480Mbps USB 2.0 Hi-Speed
RS485 Interface	Standard Windows baud rates (300bps to 921.6Kbps) Custom baud rates (300bps to 10Mbps) through baud rate aliasing. See FTDI Application Note: Configuring FT232R, FT2232 and FT232BM Baud Rates

Table 1.2 - Performance Figures

1.6 Ordering Information

Part Number	Description
USB2-H-5002	USB-COM-Plus Hi-Speed USB to 2-Port RS485 Adapter

Table 1.3 - Ordering Information

2 Installation

2.1 Example Applications and Configurations

2.2 Hardware Installation

There are no switches or jumpers to configure on the USB-COM-Plus USB2-H-5002.

2.2.1 Mounting

The USB2-H-5002 is provided with two mounting options: UniClip™ Wall/DIN rail mount and rubber feet. The UniClip Wall/DIN rail mount allows the USB2-H-5002 to be permanently mounted to a wall or attached to a DIN rail. The rubber feet can be used when mobility or desktop use is desired. NOTE: The UniClip provides a permanent mounting style. The USB2-H-5002 case may be damaged if the UniClip is removed.

The following figures indicate various mounting styles.



Figure 2.1 - USB2-H-5002 with UniClip Brackets



Figure 2.2 - USB2-H-5002 with Rubber Feet

2.2.2 Wiring

A standard 0.9m USB "A" to "Mini B" cable is provided.

Insert the A-plug into an available USB Host or Hub port. Insert the Mini B-plug into the B-receptacle on the USB2-H-5002.

DTE Pin Number	Signal Name	Expected Connect Signal
1	DATA- = Transmit/Receive Data, negative polarity Also Terminator 2	DATA- Pin 2 of 120R Terminating Resistor. Only Required if the USB2-H-5002 is the first or last device in a multi-drop RS485 System, to meet RS485 Termination Requirements.
2	DATA+ = Transmit/Receive Data, positive polarity	DATA+
3	Terminator 1	Pin 1 of 120R Terminating Resistor. Only Required if the USB2-H-5002 is the first or last device in a multi-drop RS485 System, to meet RS485 Termination Requirements.
4	N/A	N/A
5	GND = signal ground	GND
6	N/A	N/A
7	echo enable terminal 1	Local echo function control. Connect to pin 8 can disable the local echo function. The local echo is enabled by default.
8	echo enable terminal 2	Local echo function control. Connect to pin7 can disable the local echo function. The local echo is enabled by default.
9	PWR = +5V DC output	PWR

Table 2.1 – RS485 DTE to DCE connection

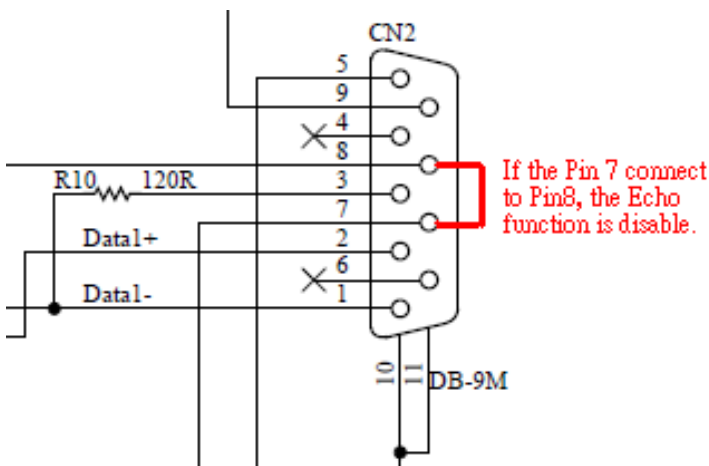

Figure 2.3 USB2-H-5002 Termination resistor and echo disable

2.3 Device Driver Installation

The USB2-H-5002 adaptor drivers are available for download from:

<http://www.easysync.co.uk> – United Kingdom site

<http://www.easysync-ltd.com> – USA site

2.3.1 Microsoft Windows

With the device drivers being Windows Hardware Quality Labs (WHQL) certified, they are also available through download directly from the Microsoft® Windows® Update service. This is the best choice when connecting the USB2-H-5002 to a computer running Windows Vista. Additional installation options are noted below:

Installation Executable on Windows XP

- 1) Login to your system as Administrator, or a user with Administrator rights.
- 2) Prior to connecting the USB2-H-5002 to the USB Host or Hub port, download the latest device driver version from the EasySync web site.
- 3) Run this executable to install the device drivers.
- 4) Connect the USB2-H-5002 to your computer. A notification will appear near the task bar indicating that new hardware has been installed and is ready for use. It is normal if this notice appears twice.

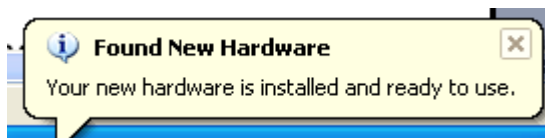

Figure 2.4 - Hardware Ready

Windows Update shown on Windows XP

You must have an active Internet connection and the Windows Update Service enabled.

- 1) Connect the USB2-H-5002 to your USB Host or Hub.
- 2) The “Found New Hardware” Wizard will appear. The first dialog should ask whether it is acceptable to use the Windows Update Service to find the device driver.



Figure 2.5 – Found New Hardware Wizard

- 3) Select one of the “Yes” choices and click “Next”.
- 4) The following screen appears:

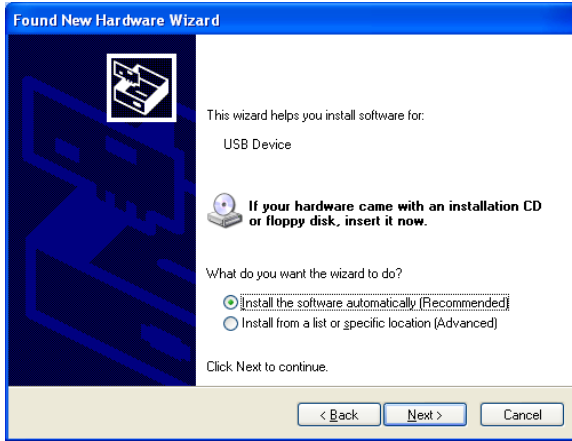

Figure 2.6 – Automatic Install

- 5) Wait while the driver is found, downloaded, and installed. This step may take a couple minutes depending on the Internet speed.
- 6) After the files are found and installed, click "Finish" to complete the installation.

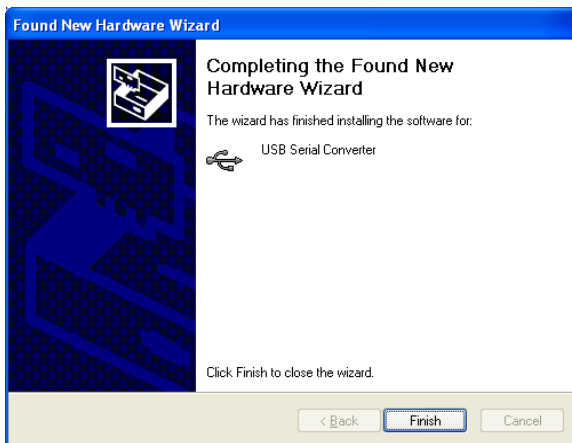

Figure 2.7 - Complete Hardware Installation

- 7) Steps 2 through 6 will repeat. The first time installs the basic USB Serial Converter in the USB device tree. The second time installs the Virtual COM Port layer in the Ports tree and assigns the COM port number.
- 8) When both portions of the device driver have been installed successfully, the following message will appear, indicating that the device is ready.

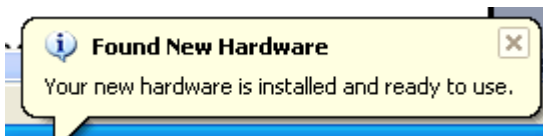

Figure 2.8 - Hardware Ready

COM Port Assignment

Next, to determine which COM port has been assigned, open the Windows Device Manager from the System Control Panel.

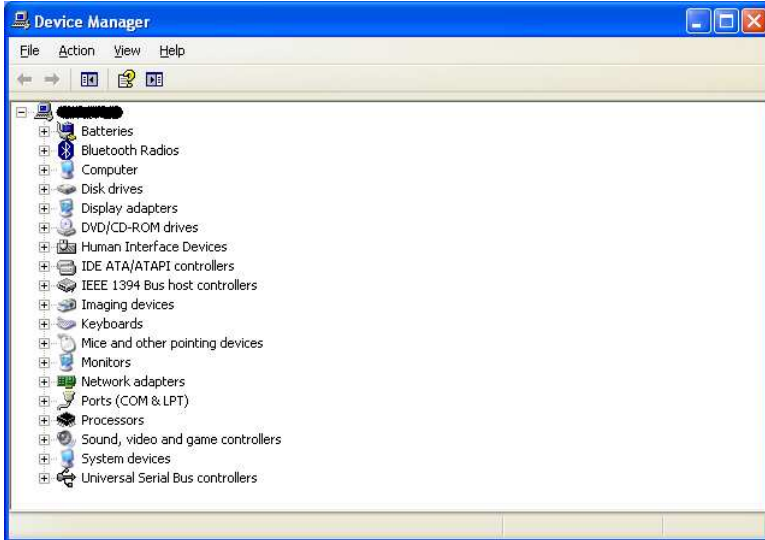

Figure 2.9 - Device Manager

Click on the Plus "+" sign next to the Ports tree to list the available COM port. You will see "EasySync USB COM Port", followed by a COMn assignment. And dual additional "EasySync USB Serial Converter A", "EasySync USB Serial Converter B".



Figure 2.10 - COM Port Assignment

To determine which COM port has been assigned to Converter A, B, the cursor point to the USB Serial Port (COM10), (COM11), then right-click on it and select "Properties", it shows their relationship to the Converter A, B.

In the figure below, the Converter A is assigned to COM10, Converter B is assigned to COM11.

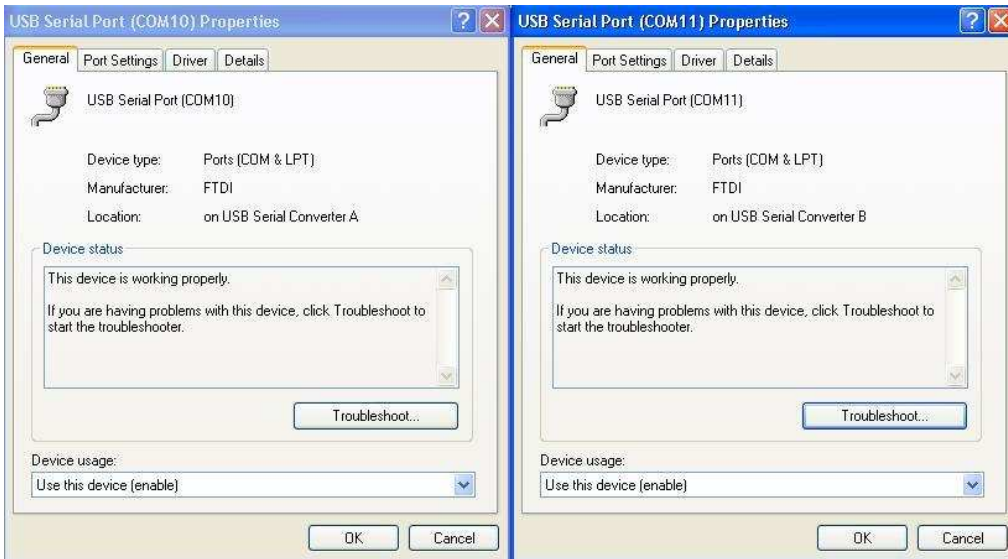

Figure 2.11 – COM Port Assignment and Properties

Use this COM port number with your application software in order to access the USB2-H-5002.

If an application requires use of a different COM port number, the assignment may be changed through the Advanced Driver Options settings.

From the above “Properties”, click on the “Port Settings” tab.



Figure 2.12 - Settings Tab

Then click on the “Advanced...” button.

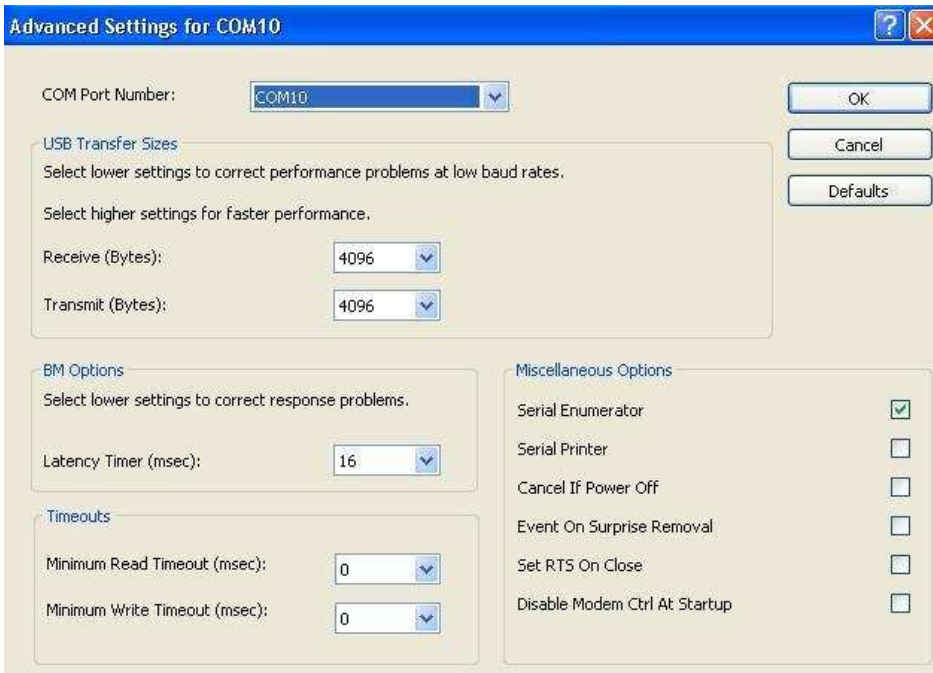

Figure 2.13 - Advanced Options

This will display the various advanced settings. Note the COM port assignment in the upper left. Clicking on the drop-down list will display the available port numbers. Select one that is not in use and click OK on each dialog box to activate the selection. Windows will remember this COM port number.

2.3.2 Mac OS X, Linux, Windows CE

Device drivers and FTDI installation guides for Mac OS X, Linux and Windows CE are available for download on the EasySync web sites. Follow the respective FTDI installation guides for the chosen operating system.

3 Connections

3.1 External Connectors

3.1.1 USB

The USB-H-5002 is a downstream USB 2.0 Device. A standard USB Series “Mini B” receptacle is mounted inside the USB-H-5002 to facilitate connection to an upstream USB Host or Hub.

Pin Number	Pin Type	Description
1	Power	VBUS – USB Power provided from upstream USB Host or Hub
2	Bidirectional	D- = USB data signal, negative polarity
3	Bidirectional	D+ = USB data signal, positive polarity
4	ID	No connected
5	Ground	GND = USB signal ground
Shield	Case Ground	Drain = typically connected to the host PC case

Table 3.1 – USB “Mini B” Receptacle Pin-Out

3.1.2 RS485

The RS485 port is configured as Data Terminal Equipment (DTE), with a 9-contact D-Sub Pin connector. Pin assignments are according to TIA/EIA-485. In addition, Pin9 of this connector can provide +5VDC to an external device with a maximum current draw of 250mA once the USB2-H-5002 has been enumerated by the system.

Pin Number	Pin Type	Description
1	Input/Output	DATA- Pin 2 of 120R Terminating Resistor. Only Required if the USB2-H-5002 is the first or last device in a multi-drop RS485 System, to meet RS485 Termination Requirements.
2	Input/Output	DATA+
3	Input	Pin 1 of 120R Terminating Resistor. Only Required if the USB2-H-5002 is the first or last device in a multi-drop RS485 System, to meet RS485 Termination Requirements.
4	N/A	N/A
5	GND = signal ground	GND
6	N/A	N/A
7	Input	Pin 7 of the local echo control. Connect to pin 8 of the echo control to disable local echo. Default is that local echo is enabled.
8	Output	Connect to pin 7 of the echo control to disable local echo. Default is that local echo is enabled.
9	PWR = +5V DC output	PWR

Table 3.2 – DE-9P RS485 Pin-Out

4 Electrical details

4.1 USB

Parameter	Description	Minimum	Typical	Maximum	Units	Conditions
USB_VCC	Input Power Voltage*	4.25	5.0*	5.25	V	*Present when USB cable is attached and USB Host or Hub powered.
I _{cc}	USB current***		30	50	mA	***Does not include power supplied to external device connected to pin 9

Table 4.1 - USB Electrical Details

4.2 RS485

Parameter	Description	Minimum	Typical	Maximum	Units	Conditions
Receiver Input						
VCM	Common-mode input voltage range	-7	+12		V	
IN	Input Current			1.0	mA	VIN = +12V
				-0.8		VIN = -7V
VTH	Differential Threshold Voltage, VTH	-0.2		+0.2	V	
VIHYST	Input Hysteresis		20		mV	
RIN	Input Resistance, RIN	12	15		kΩ	
Transmitter Output						
VOD	Differential Output Voltage, dVOD	1.5		5	V	With RL = 54Ω. CL = 50pF *
ESD Tolerance						
ESD HBM	RS485 Inputs and Outputs		±15		kV	
EN61000-4-2ContactDischarge	RS-485 Inputs and Outputs		±8		kV	
EN61000-4-2AirGapDischarge	RS-485 Inputs and Outputs		±15		kV	

Table 4.2 – RS485 Electrical Details

4.3 Power Output

The USB2-H-5002 assigns pin9 of DE-9P to provide +5V DC for an external device that requires power. The maximum allowable current that can be supplied from the USB bus is 500mA, including the circuitry of the USB2-H-5002 itself. Up to 250mA (total on 2 ports) may be used by the external devices.

Parameter	Description	Minimum	Typical	Maximum	Units	Conditions
I _o	Output Power Current	0		250	mA	USB2-H-5002

Table 4.3 - Power Output Option

5 Mechanical Details

5.1 Module Mechanical Dimensions

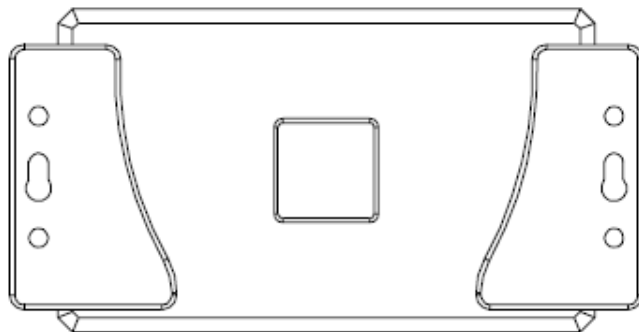
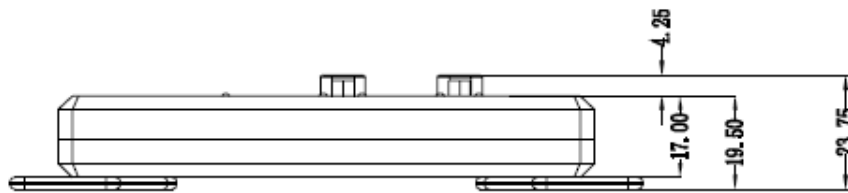
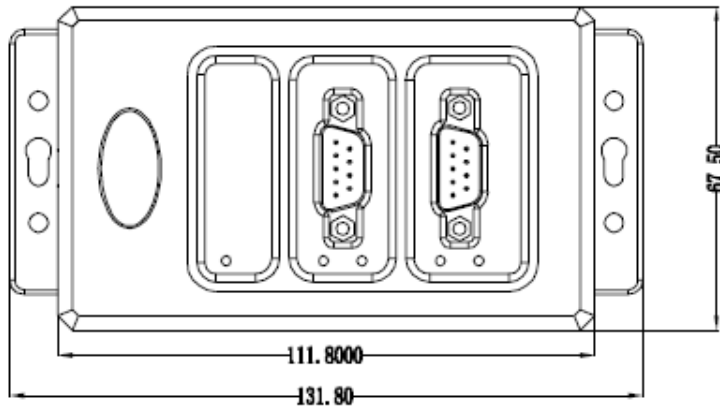

Table 5.1 - USB2-H-5002 Case Dimensions

5.2 UniClip™ Mechanical Dimensions

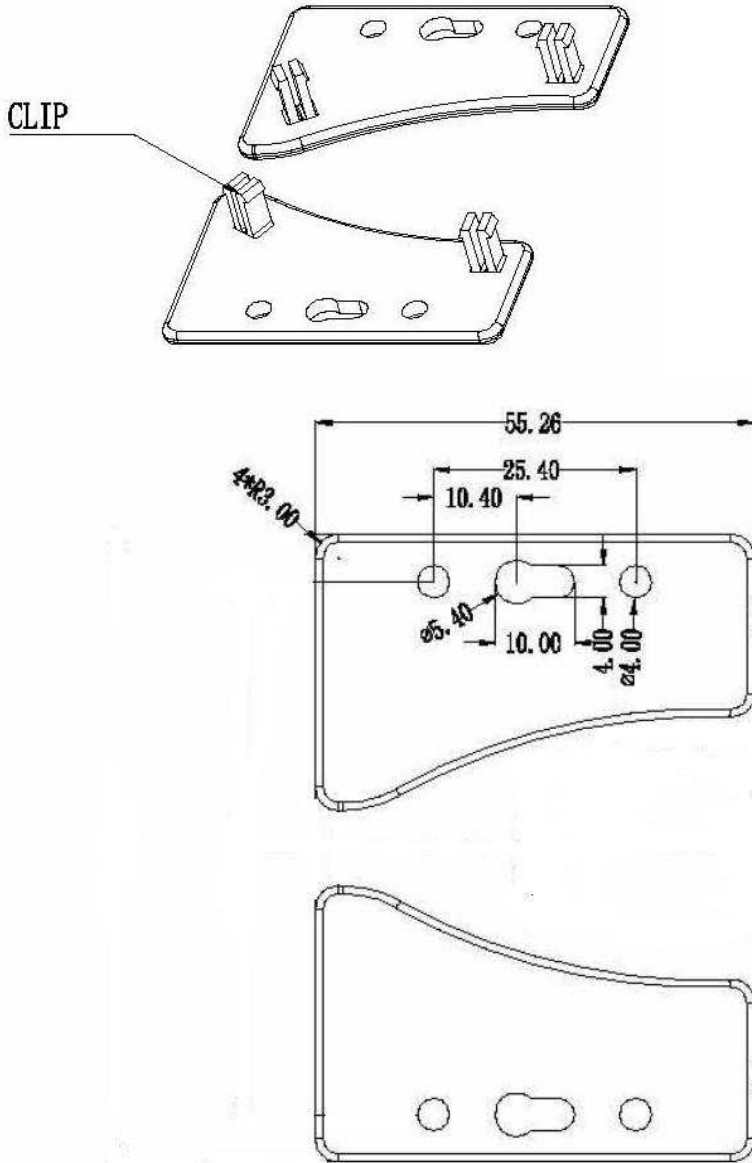

Table 5.2 - USB2-H-5002 Case Dimensions with UniClip

6 Physical Environment Details

6.1 Storage

Parameter	Description	Minimum	Typical	Maximum	Units	Conditions
T	Storage Temperature Range	-65		+150	°C	

Table 6.1 - Storage Temperature

6.2 Operating

Parameter	Description	Minimum	Typical	Maximum	Units	Conditions
T	Operating Temperature Range	-40		+85	°C	5% to 95% RH, non condensing

Table 6.2 - Operating Temperature

7 Environmental Approvals & Declarations

7.1 EMI Compatibility

FCC and CE

The USB2-H-5002 has been tested to be compliant with both FCC Part 15 Subpart B and European EMC Directive.



NOTE: This is a Class B product. In a domestic environment, this product may cause radio interference, in which case the user may be required to take adequate measures.



NOTE: This equipment has been tested and found to comply with the limits for a Class B digital device, pursuant to Part 15 of the FCC Rules. These limits are designed to provide reasonable protection against harmful interference in a residential installation. This equipment generates uses and can radiate radio frequency energy and, if not installed and used in accordance with the instructions, may cause harmful interference to radio communications. However, there is no guarantee that interference will not occur in a particular installation. If this equipment does cause harmful interference to radio or television reception, which can be determined by turning the equipment off and on, the user is encouraged to try to correct the interference by one or more of the following measures:

- Reorient or relocate the receiving antenna.
- Increase the separation between the equipment and receiver.
- Connect the equipment into an outlet on a circuit different from that to which the receiver is connected.
- Consult the dealer or an experienced radio/TV technician for help.

7.2 Safety

The USB2-H-5002 is defined as Limited Power Supply (LPS) device, with operating voltages under 60VDC.

7.3 Environmental

The USB2-H-5002 is a lead-free device that complies with the following environmental directives: RoHS, WEEE, REACH, PFOS and DecaBDE.

7.4 Reliability

The USB2-H-5002 is designed as a robust USB-Serial adapter for use in many environments. There are no user-serviceable parts. Any failure will require a replacement of the unit.

7.4.1 MTTF

The Mean Time To Failure is calculated at TBD hours.

7.5 Import / Export Information

Import / Export Information	
Country of Origin	China
Harmonized Code	TBD
Product Description	USB to RS485 Computer Adapter, Dual Ports
USA ECCN	EAR99 – No License Required

Table 7.1 - Import / Export Information

8 Troubleshooting

8.1 Hardware

Cables are the most common sources of trouble with external devices.

Check the following:

- USB cable is properly inserted at both ends
- Computer power is ON
- Computer is not in Sleep or Standby
- If a USB Hub is used, be sure it is set for "Self-Powered" operation
- If a USB Hub is used, be sure all cables are properly inserted
- If all the above are OK, the Yellow LED should be lit, indicating the device has been recognized by the USB subsystem.

RS485 cables – check the following:

- Check for specific handshake requirements of your RS485 peripheral.
- Because there are no handshake signals, ensure the application is set to "No Hardware Handshake", or equivalent.
- Test the port with a loop-back connector. Connect DATA+ to DATA+, DATA- to DATA-. Use a simple terminal program to check that data is transmitted and received.

8.2 Device Driver

Ensure the latest device driver is in use. See <http://www.easysync.co.uk> or <http://www.easysync-ltd.com>.

If other devices with FTDI chips are installed in the system, check with all manufacturers of these devices for the latest device drivers.

See the FTDI installation guides for additional details: <http://ftdichip.com/Documents/InstallGuides.htm>

Common Windows Device Driver Troubles:

- **DEVICE TIMES OUT:** The default settings of the device driver assume typical data transfers of hundred to thousands or more bytes at a given time. Some applications, such as a GPS device, only send data in short packets, often only a few bytes. If this is the case, it may be necessary to adjust the drivers buffer size and/or latency timer to smaller values. These values can be adjusted through the Advanced driver options as noted in Figure 2.13. The buffer size can be reduced to 64 bytes. The latency timer can be set as low as 2ms. A setting of 1ms will cause unnecessary USB traffic and could adversely affect data transmission.
- **ERRATIC MOUSE POINTER:** The device driver defaults to query an attached device to find out whether it is a mouse or modem, consistent with native COM port operation. Some RS485 peripherals constantly send short packets of data, causing the host system to "think" a mouse or modem has been attached. These short packets will interfere with normal mouse operation causing the pointer to jump around the screen. If this happens, disconnect the RS485 device and *uncheck the Serial Enumerator* option, also found on the Advanced driver options screen in Figure 2.13.
- **COM PORT IN USE:** Windows keeps track of all COM port assignments. If multiple EasySync products have been connected to a single system, the COM port number will increase, even if the other devices are not attached. If the higher COM port assignments are not acceptable for the application, known unused COM port numbers should be uninstalled according to the FTDI installation guide: <http://ftdichip.com/Documents/InstallGuides.htm>.

8.3 Technical Support

Technical support may be obtained from your nearest EasySync office:

United Kingdom: support@easysync.co.uk

United States: support@easysync-ltd.com

9 Contact Information

Head Office – Glasgow, UK

EasySync Limited
Unit 1, 2 Seaward Place,
Centurion Business Park
Glasgow, G41 1HH
United Kingdom
Tel: +44 (0) 141 418 0181
Fax: +44 (0) 141 418 0110

E-mail (Sales)	sales@easysync.co.uk
E-mail (Support)	support@easysync.co.uk
E-mail (General Enquiries)	admin@easysync.co.uk
Web Site URL	http://easysync.co.uk
Web Shop URL	http://easysync.co.uk

Branch Office – Hillsboro, Oregon, USA

EasySync Limited (USA)
7235 NW Evergreen Parkway, Suite 600
Hillsboro, OR 97123-5803
USA
Tel: +1 (503) 547 0909
Fax: +1 (503) 547 0990

E-Mail (Sales)	sales@easysync-ltd.com
E-Mail (Support)	support@easysync-ltd.com
E-Mail (General Inquiries)	admin@easysync-ltd.com
Web Site URL	http://easysync-ltd.com
Web Shop URL	http://easysync-ltd.com

Appendix A - List of Figures and Tables

List of Figures

Figure 1.1 USB2-H-5002	4
Figure 1.2 USB2-H-5002 Block Diagram.....	6
Figure 2.1 - USB2-H-5002 with UniClip Brackets.....	9
Figure 2.2 - USB2-H-5002 with Rubber Feet	9
Figure 2.3 USB2-H-5002 Termination resistor and echo disable.....	10
Figure 2.4 - Hardware Ready	11
Figure 2.5 – Found New Hardware Wizard.....	11
Figure 2.6 – Automatic Install.....	12
Figure 2.7 - Complete Hardware Installation	12
Figure 2.8 - Hardware Ready	12
Figure 2.9 - Device Manager	13
Figure 2.10 - COM Port Assignment	13
Figure 2.11 – COM Port Assignment and Properties	14
Figure 2.12 - Settings Tab.....	14
Figure 2.13 - Advanced Options.....	15

List of Tables

Table 1.1 – LED Description	6
Table 1.2 - Performance Figures	8
Table 1.3 - Ordering Information	8
Table 2.1 – RS485 DTE to DCE connection.....	10
Table 3.1 – USB "Mini B" Receptacle Pin-Out	16
Table 3.2 – DE-9P RS485 Pin-Out.....	17
Table 4.1 - USB Electrical Details.....	18
Table 4.2 – RS485 Electrical Details	19
Table 4.3 - Power Output Option.....	19
Table 5.1 - USB2-H-5002 Case Dimensions	20
Table 5.2 - USB2-H-5002 Case Dimensions with UniClip	21
Table 6.1 - Storage Temperature.....	22
Table 6.2 - Operating Temperature	22
Table 7.1 - Import / Export Information.....	24

Appendix B - Revision History

Version draft	First Draft	2009-07-06
Version 1.0	First Release	11 th August 2009
Version 1.1	Reduce +5V current capability	15 th September 2009
Version 1.2	Modify the description of Echo function Changed colour to black/silver	25 th January 2010