



EasySync Ltd

S1-A-7001 RS232 to 1-Port CANbus Adapter

User Guide

Document Reference No.: ES_000008

Version 1.2

Issue Date: 2010-02-23

The S1-A-7001 provides a simple method of adapting CANbus devices to RS232.

EasySync Ltd

Unit 1, 2 Seaward Place, Centurion Business Park, Glasgow, G41 1HH, United Kingdom

Tel.: +44 (0) 141 418 0181 Fax: + 44 (0) 141 418 0110

E-Mail (Support): support@easysync.co.uk Web: <http://www.easysync.co.uk>

Neither the whole nor any part of the information contained in, or the product described in this manual, may be adapted or reproduced in any material or electronic form without the prior written consent of the copyright holder. This product and its documentation are supplied on an as-is basis and no warranty as to their suitability for any particular purpose is either made or implied. EasySync Ltd will not accept any claim for damages howsoever arising as a result of use or failure of this product. Your statutory rights are not affected. This product or any variant of it is not intended for use in any medical appliance, device or system in which the failure of the product might reasonably be expected to result in personal injury. This document provides preliminary information that may be subject to change without notice. No freedom to use patents or other intellectual property rights is implied by the publication of this document. EasySync Ltd, Unit 1, 2 Seaward Place, Centurion Business Park, Glasgow, G41 1HH, United Kingdom. Scotland Registered Number: SC224924

Copyright © 2009-10 EasySync Limited

1	Introduction	4
1.1	Functional Description	4
1.2	LED Description.....	5
	Block Diagram	6
1.2.1	Block description	6
1.3	Features.....	6
1.4	Performance Figures	7
1.5	Ordering Information.....	7
2	Installation.....	8
2.1	Example Applications and Configurations	8
2.2	Hardware Installation	8
2.2.1	Mounting.....	8
2.2.2	Wiring.....	8
2.3	Firmware Update	8
3	Connections.....	9
3.1	External Connectors	9
3.1.1	RS232.....	9
3.1.2	CANbus.....	9
4	Application Programming Interfaces.....	10
4.1	ASCII commands	10
4.1.1	Help (H, h or ?).....	11
4.1.3	Set UART Baud Rate (U).....	12
4.1.4	Set CAN Channel Timing – simple (S)	13
4.1.5	Set CAN Channel Timing – advanced (s).....	14
4.1.6	Set Acceptance Mask (m)	15
4.1.7	Set Acceptance Filter (M)	16
4.1.8	Enable Time Stamp (Z)	17
4.1.9	Open CAN Channel (O).....	18
4.1.10	Open CAN Channel for Listen Only (L).....	19
4.1.11	Close CAN Channel (C).....	20
4.1.12	Echo / Synchronize (E).....	21
4.1.13	Transmit Standard CAN Frame – 11-bit ID (t)	22
4.1.14	Transmit Extended CAN Frame – 29-bit ID (T)	23
4.1.15	Get Status Flags (F).....	24
4.1.16	Get Hardware and Firmware Versions (V)	25
4.1.17	Get Serial Number (N)	26

4.1.18	Reset Microcontroller (R)	27
4.1.19	Prepare Bootloader (B).....	28
5	Electrical details	29
5.1	Power Requirements.....	29
5.2	CANbus	29
5.3	RS232	29
6	Mechanical Details.....	30
6.1	Module Mechanical Dimensions.....	30
7	Physical Environment Details	31
7.1	Storage	31
7.2	Operating	31
8	Environmental Approvals & Declarations.....	32
8.1	EMI Compatibility.....	32
8.2	Safety	32
8.3	Environmental.....	32
8.4	Reliability.....	32
8.4.1	MTTF	32
8.5	Import / Export Information.....	33
9	Troubleshooting	34
9.1	Hardware	34
	Technical Support	35
10	Contact Information	36
	Appendix A – References	37
	Appendix B - List of Figures and Tables	38
	Appendix C - Revision History	39

1 Introduction

1.1 Functional Description

The S1-A-7001 is a RS232 to CANbus adapter which operates at up to 1Mbps on both RS232 and CANbus interfaces.

Each S1-A-7001 contains a small internal electronic circuit board mounted inside of a plastic case capable of withstanding industrial temperature ranges. The integrated electronics include a Microchip PIC with the ECAN controller. LEDs give a visual indication of the CANbus status.

The S1-A-7001 requires an external power supply with an input voltage range of +6VDC to +15VDC.

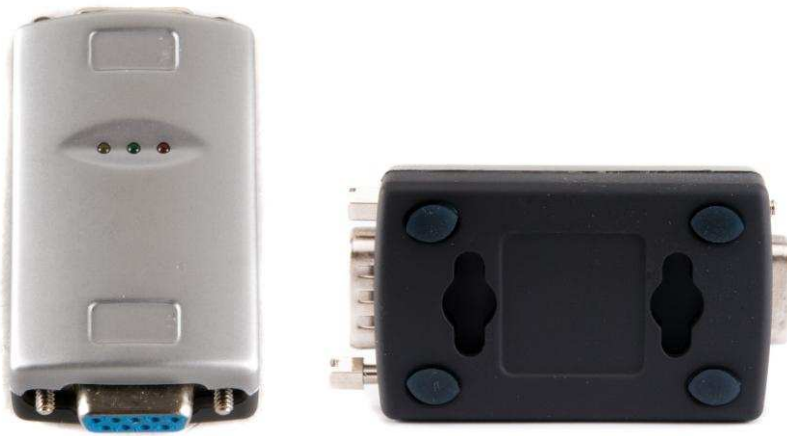

Figure 1.1 –S1-A-7001

Its small size allows the S1-A-7001 to be used in a variety of applications, from a portable adapter to accompany a laptop to permanent installations in industrial and commercial locations.

The enclosure incorporates a DE-9S connector that allows connection to an RS232 device in DTE configuration by using a straight-through cable. CANbus signals are available on an industry-standard DE-9P connector conforming to the CAN-in-Automation (CiA) DS102-2 pin-out. The maximum CANbus data rate is 1Mbps. RS232 data rates range from 2400bps to 460.8Kbps and 1Mbps.

Communications are accomplished with ASCII commands to the CAN controller. The ASCII commands are listed in [Section 4.1](#).

1.2 LED Description

The S1-A-7001 uses three LEDs to indicate a valid link as well as CANbus status. The table below uses the following LED definitions.

- ON = LED constantly lit
- OFF = LED is constantly not lit
- Blinking = 2.5Hz, alternating ON and OFF
- Single Flash = Short flash ON (200msec), followed by long off phase (1000msec)
- Double Flash = Two short flashes on (200msec) separated by short off phase (200msec), followed by long off phase (1000msec)

LED Color	Function	Description		
Yellow	Power	Power LED	State	Description
		Off	Inactive	No power is connected to the S1-A-7001
		On	Active	Power is connected to the S1-A-7001
Green	RUN	CAN Run LED	State	Description
		Blinking	PREOPERATIONAL	The device initialized
		Single flash	STOPPED	The device is in state STOPPED (Channel is Closed)
		On	OPERATIONAL	The device is in state OPERATIONAL (Channel is Open)
Red	ERR	ERR LED State	Description	Category
		Off	No error	The device is in working condition
		Blinking	Invalid Configuration	General configuration error
		Single flash	Warning limit reached	At least one of the error counters of the CAN controller has reached or exceeded the warning level (too many error frames)
On	Bus off	The CAN controller is bus off, and not involved in CANbus activities		

Table 1.1 – LED Description

Upon initial power up, system reboot or executing the (R)eset command, the RED led will blink a number of times depending on the baud rate of the RS232 port. See the "U" command in Section 4.1 for details.

Block Diagram

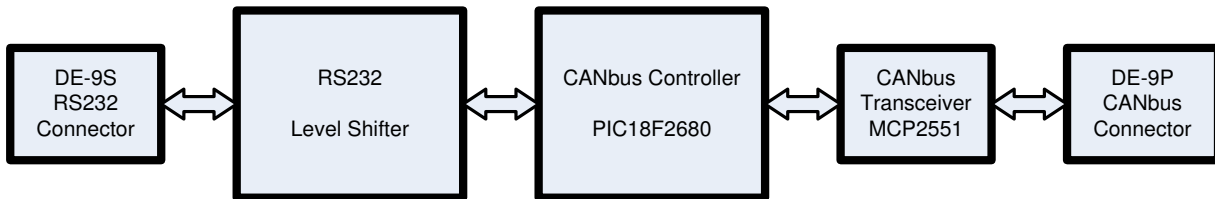

Figure 1.2 – S1-A-7001 Block Diagram

1.2.1 Block description

RS232 DE-9S Connector

This connector provides the interface for connection a RS232 device. Most PC RS232 ports or other RS232 adapters are configured for DTE. The S1-A-7001 pin connection allows use of a straight-through DE-9P to DE-9S cable. The S1-A-7001 can also be connected directly to a mating RS232 port with the integral thumb-screws.

RS232 Level Shifter

The RS232 level shifter converts the bipolar signalling of RS232 and converts it to 5V logic which is required by the CANbus Controller.

CANbus Controller

The Microchip PIC18F4680 runs firmware that converts the communication from the RS232 to CANbus protocol.

CANbus Transceiver

The Microchip MCP2551 converts logic level signals from the CANbus controller to CANbus physical signals. These signals consist of a differential pair, CAN_H and CAN_L.

DE-9P Connector (Male)

The DE-9P connector is configured in an industry standard (CiA DS102-2) pin-out to provide connection to CANbus peripherals through standard cables. See [Section 3.1.2](#).

1.3 Features

- Adds one CANbus port by connecting to RS232
- Easy installation and CANbus device connection
- Supports Windows Server 2008, 2003, Vista, XP 2000, Linux, Mac OS X and any other operating system that supports COM ports
- Wide power supply input voltage range of +6VDC to +15VDC
- CANbus speed up to 1Mbps
- CANbus connector conforms to CiA DS102-2
- LEDs indicate Initialization and CANbus status for monitoring port status & easy diagnostics
- High-temperature plastic enclosure
- Operating temperature of -40°C to +85°C

1.4 Performance Figures

Parameter	Performance
RS232 Interface	2.4Kbps, 9.6Kbps, 19.2Kbps, 38.4Kbps, 57.6Kbps (default), 115.2Kbps, 230.4Kbps, 460.8Kbps and 1.0Mbps.
CANbus Interface	10Kbps to 1Mbps

Table 1.2 – Performance Figures

1.5 Ordering Information

Part Number	Description
S1-A-7001	CAN-Plus RS232 to 1-Port CANbus Adapter

Table 1.3 – Ordering Information

2 Installation

2.1 Example Applications and Configurations

2.2 Hardware Installation

There are no switches or jumpers to configure on the S1-A-7001.

2.2.1 Mounting

The S1-A-7001 can be installed in-line with a standard RS232 DE-9P to DE-9S straight-through cable. It can also be attached directly to the back of a host computer DE-9P RS232 port.

2.2.2 Wiring

Connect the DE-9S connector to a RS232 port.

The CANbus interface is provided through a DE-9P connector as defined by the CiA DS102-2 pin-out. Bus termination is *not* provided. A CANbus network requires 120Ω termination resistors at each end as noted in Figure 2.3. Wiring to CANbus nodes through the middle of the network must ensure a short tap length.

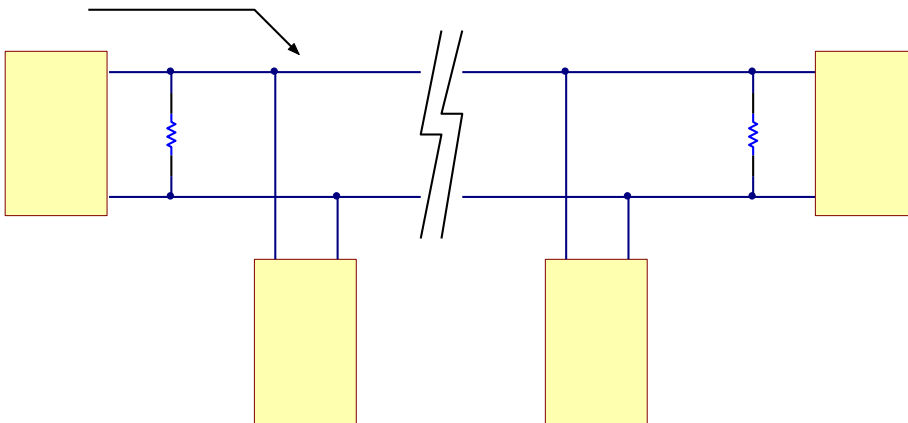

Figure 2.1 – Canbus Network

2.3 Firmware Update

The S1-A-7001 firmware can be updated for bug fixes and enhanced features. In order to update the firmware, obtain the updated firmware from the EasySync web site and follow the instructions contained in the readme file of the download.

3 Connections

3.1 External Connectors

3.1.1 RS232

The S1-A-7001 is configured to allow use of a straight-through 9-pin RS232. It can also be directly connected to a host computer port. RS232 signal names are defined in Table 3.1.

Pin Number	Pin Type	Description
2	Input	RXD = RS232 Data INPUT
3	Output	TXD = RS232 Data OUTPUT
5	Ground	GND = RS232 signal ground
7	Input	CTS = RS232 Handshake INPUT
8	Output	RTS = RS232 Handshake OUTPUT

Table 3.1 – RS232 Pin-Out

3.1.2 CANbus

The CANbus port conforms to the CiA DS102-2 pin-out through a 9-contact D-Sub Pin connector. Pin assignments are noted below:

Pin Number	Pin Type	Description
1	n/a	Not Connected
2	Bidirectional	CAN_L - CANbus low-side signal of differential pair
3	Ground	Signal Ground
4	n/a	Not Connected
5	Ground	Signal Ground
6	Ground	Signal Ground
7	Bidirectional	CAN_H – CANbus high-side signal of differential pair
8	n/a	Not Connected
9	PWR	+6V to +15V Battery Supply Voltage

Table 3.2 – DE-9P DS102-2 CANbus Pin-Out

4 Application Programming Interfaces

4.1 ASCII commands

The following ASCII commands provide a means of utilizing an interactive terminal program, or communication through a standard COM or TTY port. Unrecognized commands return the ASCII BELL character (0x07). Some useful settings for a terminal program to assist in the human readability of command responses are:

- Echo typed characters locally – the S1-A-7001 does not echo characters.
- Append line feeds to incoming carriage returns (0x0D).
- The S1-A-7001 defaults to 57.6Kbps RS232 communications. If a different RS232 bit rate is chosen, that rate will be the new default on subsequent power cycles.

The CAN messages are received at all times by default and are sent on the RS232 port immediately. The firmware version 2.2 supports sustained read of CAN messages sent 1ms apart as well as a burst of up to 100 CAN messages sent 50us apart.

4.1.1 Help (H, h or ?)

Summary

Lists available commands.

Definition

H<CR>, h<CR> or ?<CR>

Parameters

None

Remarks

Example:

?<CR>

List available commands.

Return Codes

List of Supported Commands

O - Open CAN Channel
C - Close CAN Channel
t - Transmit Standard Frame
T - Transmit Extended Frame
F - Read Status Flag
V - S1-A-7001 Version
N - Serial Number of S1-A-7001
Z - TimeStamp Option On/Off
S - Set CAN Bit Rate
s - Set BRGCON Registers
m - Set Acceptance Mask
M - Set Acceptance Filter
B - Enter Bootload Mode
L - Set Listen Mode
E - Clear Buffers and Echo Char
R - Reset S1-A-7001
U - Set UART Baud Rate
H, ? or h - Help on S1-A-7001 Commands

<CR> = OK

<BELL> = ERROR

4.1.3 Set UART Baud Rate (U)

Summary

Configure RS232 interface with a chosen baud rate. This rate is independent of the CANbus baud rate. The RS232 baud rate is stored and retained across power cycles.

Upon power-up or reset (R) of the S1-A-7001, the RED LED will flash a given number of times.

NOTE: Ensure the attached RS232 device can be configured for the new baud rate prior to using this command. Failure to do so may result in an unusable configuration. Many terminal programs do not have settings beyond 115.2Kbps. The 1.0Mbps setting *cannot* be used with a COM port set to 921.6Kbps.

Definition

Urate_selector<CR>

Parameters

LED Flash on Power-Up / Reset

rate_selector =	0 = 230.4Kbps	1
	1 = 115.2Kbps	2
	2 = 57.6Kbps (default)	3
	3 = 38.4Kbps	4
	4 = 19.2Kbps	5
	5 = 9.6Kbps	6
	6 = 2.4Kbps	7
	7 = 460.8Kbps	8
	8 = 1.0Mbps	9

Remarks

Example:

U5<CR>

Set RS232 transmission rate to 9.6Kbps

Return Codes

<CR> = OK

<BELL> = ERROR

4.1.4 Set CAN Channel Timing – simple (S)

Summary

Configure CAN interface with a pre-configured channel transmission rate.

NOTE: The CAN channel will revert to its prior state after execution. For example if the channel is Open when this command is executed, the channel will update the setting and return to the Open state.

Definition

Srate_selector<CR>

Parameters

rate_selector =	0 = 10Kbps
	1 = 20Kbps
	2 = 50Kbps
	3 = 100Kbps
	4 = 125Kbps
	5 = 250Kbps
	6 = 500Kbps
	7 = 800Kbps
	8 = 1Mbps (default)

Remarks

Example:

```
S5<CR>
```

Set CAN transmission rate to 250Kbps

Return Codes

<CR> = OK

<BELL> = ERROR

4.1.5 Set CAN Channel Timing – advanced (s)

Summary

Configure CAN interface with a custom channel transmission rate.

NOTE: The CAN channel will revert to its prior state after execution. For example if the channel is Open when this command is executed, the channel will update the setting and return to the Open state.

Definition

Saabbcc<CR>

Parameters

aa = contents of PIC 18F4680 BRGCON1 register (in hexadecimal)

bb = contents of PIC 18F4680 BRGCON2 register (in hexadecimal)

cc = contents of PIC 18F4680 BRGCON3 register (in hexadecimal)

Remarks

The S1-A-7001 utilizes a 24MHz clock for the PIC 18F4680. Use this value when referring to the PIC datasheet if a custom transmission rate different from those provided with the "S" command above is required.

Example:

```
s01BE07<CR>
```

Set CAN transmission rate to 250Kbps.

NOTE: With this command, multiple combinations of BRGCON1, BRGCON2 and BRGCON3 can yield the same bit rate.

Return Codes

<CR> = OK

<BELL> = ERROR

4.1.6 Set Acceptance Mask (m)

Summary

The Acceptance Mask, in conjunction with the Acceptance Filter (M), defines which received messages (i.e. of a specific ID or range of CAN IDs) will be passed to the RS232 interface. The Acceptance Mask value corresponds to bits within a range of valid CAN IDs for either standard or extended CAN messages.

Set Acceptance Mask (m) command should be executed *prior* to Set Acceptance Filter (M).

NOTE: The CAN channel will revert to its prior state after execution. For example if the channel is Open when this command is executed, the channel will update the setting and return to the Open state.

Definition

miii<CR> for standard 11-bit CAN messages

miiiiiiii<CR> for extended 29-bit CAN messages

Parameters

iii = standard 11-bit CAN mask (0x000 through 0x7FF)

iiiiiiii = extended 29-bit CAN mask (0x00000000 through 0x1FFFFFFF)

A value of "0" in a bit location indicates that the bit location ID value is to be *ignored* when filtering messages.

Default is to pass all frames (Acceptance Mask = 0x000 for standard messages and 0x00000000 for extended messages)

Remarks

Example

m700<CR>

Set Acceptance Mask to check bits 10, 9 and 8 against the filter. Bits 7 through 0 are ignored as "don't care". Use the Acceptance Mask in conjunction with the Acceptance Filter, defined next.

Return Codes

<CR> = OK

<BELL> = ERROR

4.1.7 Set Acceptance Filter (M)

Summary

The Acceptance Filter, in conjunction with the Acceptance Mask (m), defines which received messages (i.e. of a specific ID or range of CAN IDs) will be passed to the RS232 interface. The Acceptance Filter value corresponds to a valid CAN ID for either standard or extended CAN messages.

The Set Acceptance Mask (m) command should be executed *prior* to the Set Acceptance Filter (M) command.

NOTE: The CAN channel will revert to its prior state after execution. For example if the channel is Open when this command is executed, the channel will update the setting and return to the Open state.

Definition

Miii<CR> for standard 11-bit CAN messages

Miiiiiii<CR> for extended 29-bit CAN messages

Parameters

iii = standard 11-bit CAN ID (0x000 through 0x7FF)

iiiiiii = extended 29-bit CAN ID (0x00000000 through 0x1FFFFFFF)

Default is to pass all frames (Acceptance Filter = 0x7FF for standard messages and 0xFFFFFFFF for extended messages).

Remarks

Example

M1FF<CR>

Set Acceptance Filter to receive standard messages with the CAN ID of 0x1FF. If used in conjunction with the Acceptance Mask example above, frames of the range 0x100 through 0x1FF will be passed and all other CAN IDs blocked.

Return Codes

<CR> = OK

<BELL> = ERROR

4.1.8 Enable Time Stamp (Z)

Summary

Sets or clears time stamp on received frames. This value is persistent in EEPROM across reset or restart. Four (4) bytes are added to the end of a received frame. This value is a rolling 16-bit counter that increments once every millisecond and rolls over at 60,000mS (1 minute). Valid hex values are 0x0000 through 0xEA5F.

NOTE: The CAN channel will revert to its prior state after execution. For example if the channel is Open when this command is executed, the channel will update the setting and return to the Open state.

Definition

Zn<CR>

Parameters

- n = 0 = disable time stamp feature
- 1 = enable time stamp feature

Remarks

Default is OFF (disable time stamp)

Only use when required to change functionality.

Example:

Z1<CR>

Enable time stamp.

Return Codes

<CR> = OK

<BELL> = ERROR

4.1.9 Open CAN Channel (O)

Summary

Opens CAN channel for read/write operations. CAN channel must be initiated with selected speed (S or s) prior to use of Open.

Definition

O<CR>

Parameters

None

Remarks

Example:

O<CR>

Open CAN channel in normal communication mode.

Once the CAN channel is open, it is necessary to execute the Echo/Synchronize (E or e) command to flush the data buffers. Once the CAN channel is synchronized, received data is automatically sent from the CAN network to the controlling application.

Return Codes

<CR> = OK

<BELL> = ERROR

4.1.10 Open CAN Channel for Listen Only (L)

Summary

Opens the CAN channel in Listen Only mode. This is essentially the same as Open, although attempts to use either Transmit command (T or t) will result in an error. Listen Only mode is useful for monitoring the CAN channel without interaction from the CAN bus. CAN channel must be initiated with selected speed (S or s) prior to use of Listen.

When in Listen mode, the channel must first be Closed (C) and then opened with Open (O) prior to attempting to transmit frames.

NOTE: A minimum of three nodes are required on the CANbus network for Listen mode to function.

Definition

L<CR>

Parameters

None

Remarks

Example:

L<CR>

Open CAN channel in Listen Only mode

Received data is automatically sent from the CAN network to the controlling application.

Return Codes

<CR> = OK

<BELL> = ERROR

4.1.11 Close CAN Channel (C)

Summary

Closes the CAN channel. This command provides backward compatibility with some existing CANbus adapters.

Definition

C<CR>

Parameters

None

Remarks

Example:

C<CR>

Close CAN channel.

Return Codes

<CR> = OK

<BELL> = ERROR

4.1.12 Echo / Synchronize (E)

Summary

Clear transmit data buffers. Data buffers should be cleared immediately after opening the CAN channel to prevent erroneous as a result of sending old data in the buffer.

Definition

E<CR>

Parameters

None

Remarks

Example:

E<CR>

Clear data buffers.

Return Codes

E<CR> = OK

<BELL> = ERROR

4.1.13 Transmit Standard CAN Frame – 11-bit ID (t)

Summary

Transmits a standard CAN frame with an 11-bit ID. The CAN channel must be Open (O) prior to transmitting any messages.

Definition

tiiiidd..dd<CR>

Parameters

iii = 3-digit identifier in hex (000 through 7FF)

l = Length (number of bytes) of data message

dd = Data bytes in hex (00 through FF).

The number of bytes must match message length

Remarks

Example:

t34580123456789ABCDEF

Transmit a 11-bit ID frame with

ID = 0x345

Data = 0x01, 0x23, 0x45, 0x67, 0x89, 0xAB, 0xCD, 0xEF

Example:

t4560

Transmit an 11-bit ID frame with

ID = 0x456

Data = zero bytes (no data)

Return Codes

z<CR> = OK

<BELL> = ERROR

4.1.14 Transmit Extended CAN Frame – 29-bit ID (T)

Summary

Transmits an extended CAN frame with a 29-bit ID. The CAN channel must be Open (O) prior to transmitting any messages.

Definition

Tiiiiiiiidd..dd<CR>

Parameters

iiiiiii = 8-digit identifier in hex (00000000 through 1FFFFFFF)

l = Length (number of bytes) of data message

dd = Data bytes in hex (00 through FF).
The number of bytes must match message length

Remarks

Example:

T1234567880123456789ABCDEF

Transmit a 29-bit ID frame with

ID = 0x12345678

Data = 0x01, 0x23, 0x45, 0x67, 0x89, 0xAB, 0xCD, 0xEF

Example:

T123456780

Transmit an 11-bit ID frame with

ID = 0x12345678

Data = zero bytes (no data)

Return Codes

Z<CR> = OK

<BELL> = ERROR

4.1.15 Get Status Flags (F)

Summary

Get CANbus and controller status. A two-byte BCD number is returned to correspond to the 8-bits of the COMSTAT register of the PIC18F4680.

Definition

F<CR>

Parameters

None

Remarks

Example

F<CR>

Get CANbus status

Return Codes

xx<CR> = OK

xx = CANbus status (A bit set to "1" indicates a true condition):

- bit 0 = Flag bit 1 -or- Flag bit 2 is set
- bit 1 = Receive Warning: 127 >= Receive Error Counter > 95
- bit 2 = Transmit Warning: Transmit Error Counter > 95
- bit 3 = Receive Bus Passive: Receive Error Counter > 127
Will cause RED LED to Single Flash
- bit 4 = Transmit Bus Passive: Transmit Error Counter > 127
Will cause RED LED to Single Flash
- bit 5 = Transmit Bus-OFF: Transmit Error Counter > 255
Will cause RED LED to remain ON
- bit 6 = Receive Buffer 1 Overflow
- bit 7 = Receive Buffer 0 Overflow

<BELL> = ERROR

4.1.16 Get Hardware and Firmware Versions (V)

Summary

Get hardware and firmware version numbers of S1-A-7001. Each value consists of a two-digit, binary coded decimal (BCD) number.

Definition

V<CR>

Parameters

None

Remarks

Example

V<CR>

Get serial number

Return Codes

Vxxyy<CR> = OK

xx = hardware version

yy = firmware version

<BELL> = ERROR

4.1.17 Get Serial Number (N)

Summary

Get serial number of S1-A-7001.

Definition

N<CR>

Parameters

None

Remarks

Example

N<CR>

Get serial number

Return Codes

Nxxxx<CR> = OK

xxxx = serial number of the S1-A-7001. It is possible to have alphanumeric values.

<BELL> = ERROR

4.1.18 Reset Microcontroller (R)

Summary

Resets PIC18F4680 MCU. Configurations are preserved in EEPROM. This command is useful if the S1-A-7001 becomes unresponsive. The RED LED will flash to indicate the RS232 baud rate, followed by entering the state mentioned in [Section 1.2](#).

The RS232 baud rate set by the U command is not changed.

The CANbus data rate is reset to 1Mbps.

Definition

R<CR>

Parameters

None

Remarks

Example

R<CR>

Reset PIC18F4680

Return Codes

<CR> = OK.

<BELL> = ERROR

4.1.19 Prepare Bootloader (B)

Summary

Resets PIC18F4680 MCU into Bootloader mode. Only use this command immediately prior to loading new firmware onto the S1-A-7001.

Definition

B<CR>

Parameters

None

Remarks

Example

B<CR>

Prepare to load new firmware

Return Codes

Entering Bootloader Mode...

Boot:>

<BELL> = ERROR

5 Electrical details

5.1 Power Requirements

Parameter	Description	Minimum	Typical	Maximum	Units	Conditions
VCC	Input Power Voltage	6.0		15	V	
I _{cc}	Supply current	10	40*	100**	mA	*Normal operation **Fault condition of CANbus in constant Dominant state

Table 5.1 – Power Supply Electrical Details

5.2 CANbus

Parameter	Description	Minimum	Typical	Maximum	Units	Conditions
V _{trans}	Transmitter output voltage swing	0.5		4.5	V	See Microchip MCP2551 datasheet for complete details
V _{rec}	Receiver input voltage range	-0.3		5.3	V	See Microchip MCP2551 datasheet for complete details
	ESD HBM		± 6		KV	See Microchip MCP2551 datasheet for complete details

Table 5.2 – CANbus Electrical Details

5.3 RS232

Parameter	Description	Minimum	Typical	Maximum	Units	Conditions
V _{trans}	Transmitter output voltage swing	±5		+15	V	R _L = 3K
V _{rec}	Receiver input voltage range	-25		+25	V	
	ESD HBM		15		KV	

Table 5.3 – RS232 Electrical Details

6 Mechanical Details

6.1 Module Mechanical Dimensions

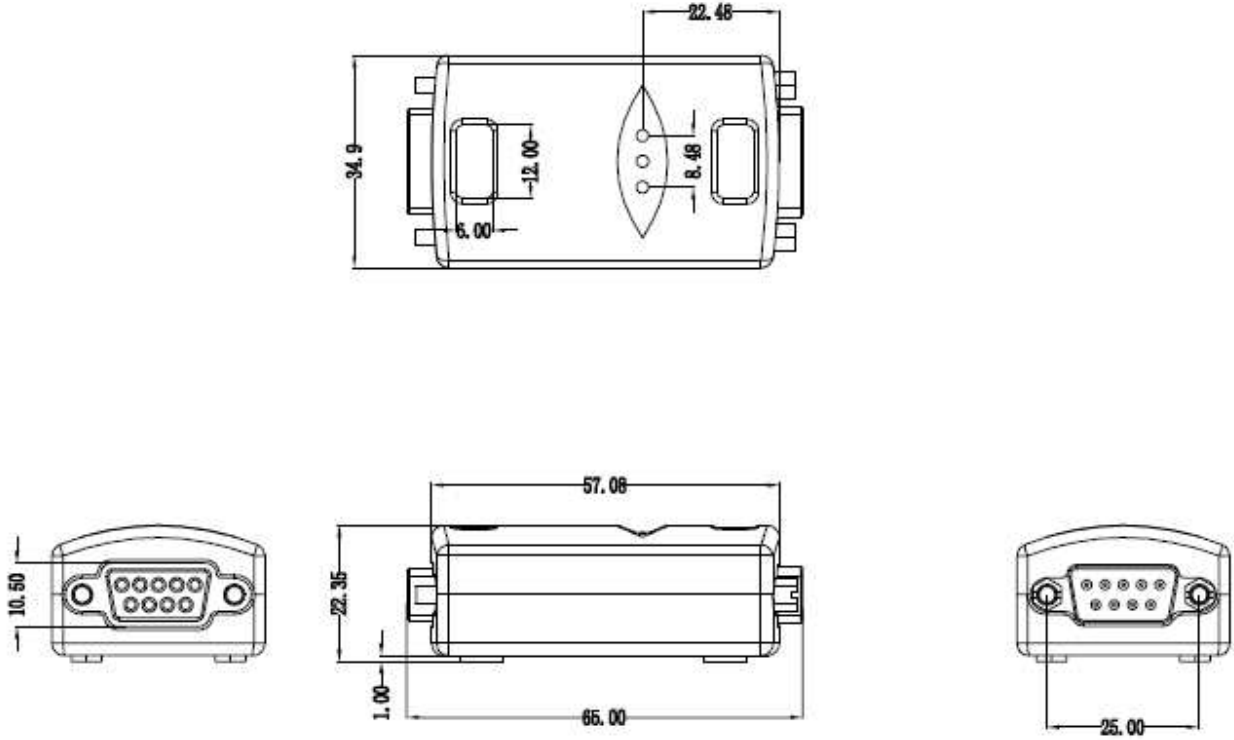

Figure 6.1 – S1-A-7001 Case Dimensions

7 Physical Environment Details

7.1 Storage

Parameter	Description	Minimum	Typical	Maximum	Units	Conditions
T	Storage Temperature Range	TBD		TBD	°C	

Table 7.1 – Storage Temperature

7.2 Operating

Parameter	Description	Minimum	Typical	Maximum	Units	Conditions
T	Operating Temperature Range	-40		+85	°C	5% to 95% RH, non condensing

Table 7.2 – Operating Temperature

8 Environmental Approvals & Declarations

8.1 EMI Compatibility

FCC and CE

The S1-A-7001 has been tested to be compliant with both FCC Part 15 Subpart B and European EMC Directive.



NOTE: This is a Class B product. In a domestic environment, this product may cause radio interference, in which case the user may be required to take adequate measures.



NOTE: This equipment has been tested and found to comply with the limits for a Class B digital device, pursuant to Part 15 of the FCC Rules. These limits are designed to provide reasonable protection against harmful interference in a residential installation. This equipment generates, uses and can radiate radio frequency energy and, if not installed and used in accordance with the instructions, may cause harmful interference to radio communications. However, there is no guarantee that interference will not occur in a particular installation. If this equipment does cause harmful interference to radio or television reception, which can be determined by turning the equipment off and on, the user is encouraged to try to correct the interference by one or more of the following measures:

- Reorient or relocate the receiving antenna.
- Increase the separation between the equipment and receiver.
- Connect the equipment into an outlet on a circuit different from that to which the receiver is connected.
- Consult the dealer or an experienced radio/TV technician for help.

8.2 Safety

The S1-A-7001 is defined as Limited Power Supply (LPS) device, with operating voltages under 60VDC..

8.3 Environmental

The S1-A-7001 is a lead-free device that complies with the following environmental directives: RoHS, WEEE, REACH, PFOS and DecaBDE.

8.4 Reliability

The S1-A-7001 is designed as a robust RS232-CANbus adapter for use in many environments. There are no user-serviceable parts. Any failure will require a replacement of the unit.

8.4.1 MTTF

The Mean Time To Failure is TBD.

8.5 Import / Export Information

Import / Export Information	
Country of Origin	China
Harmonized Code	8471.80.1000
Product Description	RS232 to CANbus Computer Adapter, Single Port
USA ECCN	EAR99 – No License Required

Table 8.1 – Import / Export Information

9 Troubleshooting

9.1 Hardware

If the Yellow LED is not lit when plugged into CANbus connector, check the following:

- All cables are properly inserted and secured
- External power supply is ON and in the range of +6VDC to +15VDC

If communication appears to be functioning to the S1-A-7001, but CAN communication is not functioning, the CANbus cables may need checked:

- Termination: The CANbus network requires 120ohm termination at the furthest points on the network. If additional termination resistors are present through the CANbus network or if one of the termination resistors is missing at one of the ends, the CANbus network will not communicate.
- Twisted Pair: The CANbus network consists of a differential pair of signals which greatly reduce noise on the signals. Failure to use twisted pair may cause erroneous communications, or cause the CANbus network to completely fail communications.
- Polarity: The CANbus network consists of a CAN_H and CAN_L signal. Care must be taken to follow the polarity. Always connect CAN_H to CAN_H, and CAN_L to CAN_L.

Ensure the CANbus network is only connected to the S1-A-7001 *after* connection to a RS232 port. See [Section 1.2](#) for default LED power-up patterns. The CANbus network can remain connected through system reboots.

Technical Support

Technical support may be obtained from your nearest EasySync office:

United Kingdom: support@easysync.co.uk

United States: support@easysync-ltd.com

10 Contact Information

Head Office – Glasgow, UK

EasySync Limited
Unit 1, 2 Seaward Place,
Centurion Business Park
Glasgow, G41 1HH
United Kingdom
Tel: +44 (0) 141 418 0181
Fax: +44 (0) 141 418 0110

E-mail (Sales)	sales@easysync.co.uk
E-mail (Support)	support@easysync.co.uk
E-mail (General Enquiries)	admin@easysync.co.uk
Web Site URL	http://easysync.co.uk
Web Shop URL	http://easysync.co.uk

Branch Office – Hillsboro, Oregon, USA

EasySync Limited (USA)
7235 NW Evergreen Parkway, Suite 600
Hillsboro, OR 97123-5803
USA
Tel: +1 (503) 547 0909
Fax: +1 (503) 547 0990

E-Mail (Sales)	sales@easysync-ltd.com
E-Mail (Support)	support@easysync-ltd.com
E-Mail (General Inquiries)	admin@easysync-ltd.com
Web Site URL	http://easysync-ltd.com
Web Shop URL	http://easysync-ltd.com

Appendix A – References

Bosch CAN Specification, Version 2.0:

<http://www.semiconductors.bosch.de/pdf/can2spec.pdf>

CAN in Automation (CiA):

www.can-cia.org

Microchip

www.microchip.com

Appendix B - List of Figures and Tables

List of Figures

Figure 1.1 – S1-A-7001	4
Figure 1.2 – S1-A-7001 Block Diagram	6
Figure 2.1 – Canbus Network	8
Figure 6.1 – S1-A-7001 Case Dimensions	30

List of Tables

Table 1.1 – LED Description	5
Table 1.2 – Performance Figures	7
Table 1.3 – Ordering Information	7
Table 3.1 – RS232 Pin-Out	9
Table 3.2 – DE-9P DS102-2 CANbus Pin-Out	9
Table 5.1 – Power Supply Electrical Details	29
Table 5.2 – CANbus Electrical Details	29
Table 5.3 – RS232 Electrical Details	29
Table 7.1 – Storage Temperature	31
Table 7.2 – Operating Temperature	31
Table 8.1 – Import / Export Information	33

Appendix C - Revision History

Version draft	Initial Draft	20 th March 2009
Version draft	2nd Draft	11 th May 2009
Version draft	3 rd Draft	18 th May 2009
Version 1.0	1 st Release	19 th May 2009
Version 1.01	Corrected Get Flags "F" command return value Corrected power input voltage range	20 th May 2009
Version 1.1	Changed "Acceptance Code" to "Acceptance Filter" throughout the document. Corrected Acceptance Mask and Acceptance Filter definitions.	9 th July 2009
Version 1.2	Changed to silver/black enclosure	23 rd Feb 2010