

# RID-50 series

## 50W Dual Output Switching Power Supply

# STONTRONICS

THE POWER TO SUPPLY

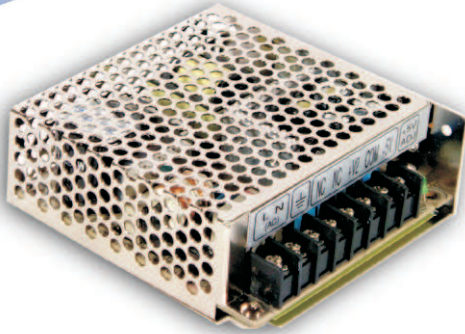

### ■ Features :

- Isolated output & GND for CH1, CH2
- Universal AC input / Full range
- Protections: Short circuit / Overload / Over voltage
- Cooling by free air convection
- LED indicator for power on
- 100% full load burn-in test
- All using 105°C long life electrolytic capacitors
- Withstand 300VAC surge input for 5 second
- High operating temperature up to 70°C
- Withstand 5G vibration test
- High efficiency, long life and high reliability
- 3 years warranty

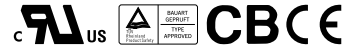

### SPECIFICATION

MODEL	RID-50A		RID-50B		
OUTPUT	OUTPUT NUMBER	CH1	CH2	CH1	CH2
	DC VOLTAGE	5V	12V	5V	24V
	RATED CURRENT	6A	2A	4A	1.4A
	CURRENT RANGE	0.3 ~ 6A	0.3 ~ 3A	0.3 ~ 6A	0.2 ~ 2A
	RATED POWER	54W		53.6W	
	RIPPLE & NOISE (max.) Note.2	80mVp-p	120mVp-p	80mVp-p	150mVp-p
	VOLTAGE ADJ. RANGE	CH1: 4.75 ~ 5.5V		CH1: 4.75 ~ 5.5V	
	VOLTAGE TOLERANCE Note.3	±2.0%	±8.0%	±2.0%	+8,-4%
	LINE REGULATION Note.4	±0.5%	±1.5%	±0.5%	±1.5%
	LOAD REGULATION Note.5	±0.5%	±5.0%	±0.5%	±5.0%
SETUP, RISE TIME	500ms, 20ms/230VAC 1200ms, 30ms/115VAC at full load				
HOLD UP TIME (Typ.)	60ms/230VAC	14ms/115VAC at full load			
INPUT	VOLTAGE RANGE	88 ~ 264VAC	125 ~ 373VDC (Withstand 300VAC surge for 5sec. Without damage)		
	FREQUENCY RANGE	47 ~ 63Hz			
	EFFICIENCY (Typ.)	80%	81%		
	AC CURRENT (Typ.)	1.3A/115VAC	0.8A/230VAC		
	INRUSH CURRENT (Typ.)	COLD START 33A/230VAC			
	LEAKAGE CURRENT	<2mA / 240VAC			
PROTECTION	OVERLOAD	110 ~ 150% rated output power Protection type : Hiccup mode, recovers automatically after fault condition is removed			
	OVER VOLTAGE	CH1: 5.75 ~ 6.75V Protection type : Hiccup mode, recovers automatically after fault condition is removed			
ENVIRONMENT	WORKING TEMP.	-25 ~ +70°C (Refer to output load derating curve)			
	WORKING HUMIDITY	20 ~ 90% RH non-condensing			
	STORAGE TEMP., HUMIDITY	-40 ~ +85°C, 10 ~ 95% RH			
	TEMP. COEFFICIENT	±0.03%/°C (0 ~ 50°C) on +5V output			
	VIBRATION	10 ~ 500Hz, 5G 10min./1cycle, period for 60min. each along X, Y, Z axes			
SAFETY & EMC (Note 6)	SAFETY STANDARDS	UL60950-1, TUV EN60950-1 approved			
	WITHSTAND VOLTAGE	I/P-O/P:3KVAC I/P-FG:1.5KVAC O/P-FG:0.5KVAC			
	ISOLATION RESISTANCE	I/P-O/P, I/P-FG, O/P-FG:100M Ohms / 500VDC / 25°C / 70% RH			
	EMI CONDUCTION & RADIATION	Compliance to EN55022 (CISPR22) Class B			
	HARMONIC CURRENT	Compliance to EN61000-3-2,-3			
	EMS IMMUNITY	Compliance to EN61000-4-2,3,4,5,6,8,11; ENV50204, EN61000-6-2 (EN50082-2), heavy industry level, criteria A			
OTHERS	MTBF	172.6Khrs min. MIL-HDBK-217F (25°C)			
	DIMENSION	99*97*36mm (L*W*H)			
	PACKING	0.41Kg; 45pcs/19.5Kg/0.9CUFT			
NOTE	<ol style="list-style-type: none"> <li>1. All parameters NOT specially mentioned are measured at 230VAC input, rated load and 25°C of ambient temperature.</li> <li>2. Ripple &amp; noise are measured at 20MHz of bandwidth by using a 12" twisted pair-wire terminated with a 0.1uf &amp; 47uf parallel capacitor.</li> <li>3. Tolerance : includes set up tolerance, line regulation and load regulation.</li> <li>4. Line regulation is measured from low line to high line at rated load.</li> <li>5. Load regulation is measured from 0% to 100% rated load.</li> <li>6. The power supply is considered a component which will be installed into a final equipment. The final equipment must be re-confirmed that it still meets EMC directives.</li> </ol>				

## Mechanical Specification

Case No. 905B Unit:mm

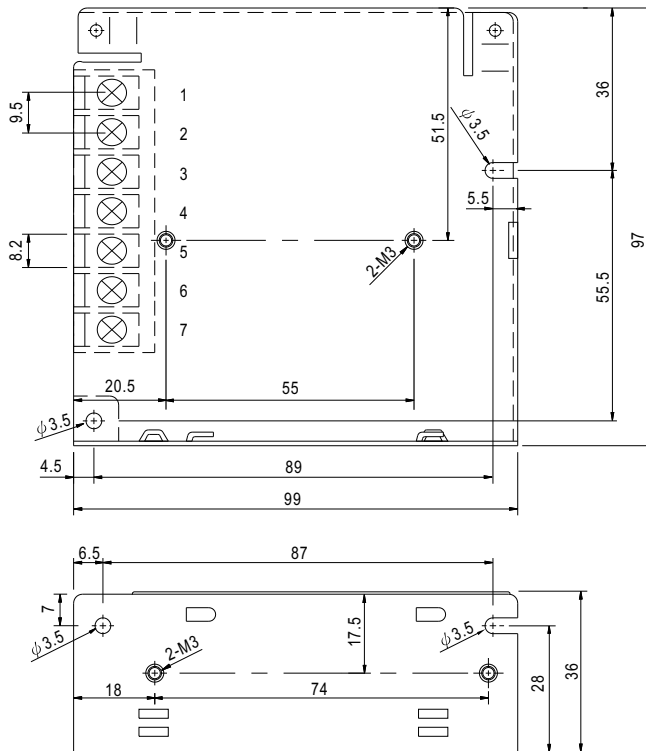

Terminal Pin No. Assignment

Pin No.	Assignment	Pin No.	Assignment
1	AC/L	5	DC OUTPUT +V2
2	AC/N	6	DC OUTPUT G1
3	FG $\equiv$	7	DC OUTPUT +V1
4	DC OUTPUT G2		

## Block Diagram

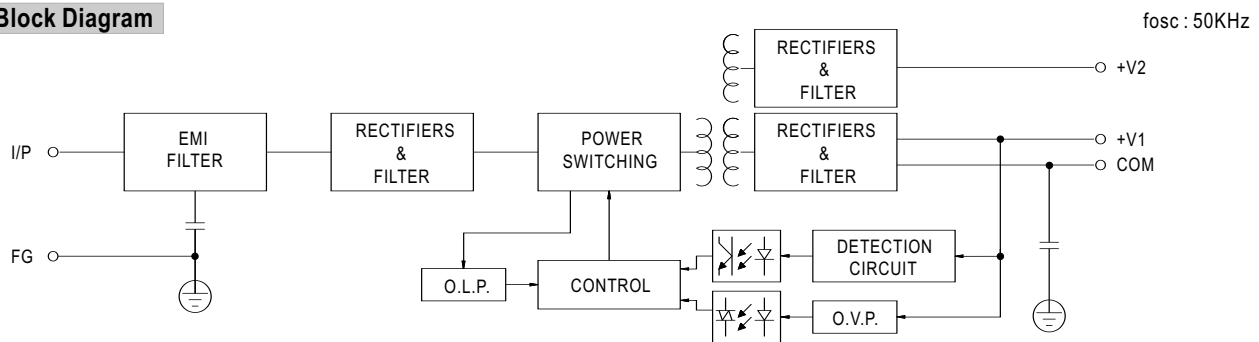

## Derating Curve

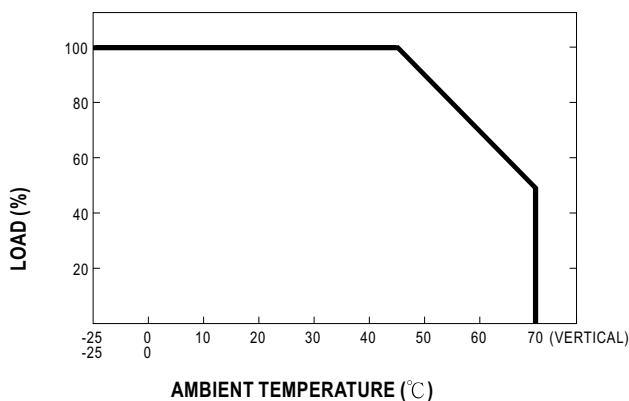

## Output Derating VS Input Voltage

