



Solving your relay requirements since 1922

Amperite Co.

(800) 752-2329

www.Amperite.com

HDOD Series Delay-On-Dropout Time Delay Relay

- Solid state CMOS digital circuitry
- True delay on dropout: Timing cycle after power removal
- DPDT (2 form C) isolated 4 ampere relay contacts
- Built-in timing adjust potentiometer
- Numerous models from 0.1 seconds to hours



Timing Mode

Upon the application of input voltage the relay immediately energizes. The timing cycle begins when input voltage is removed. When the timing cycle is complete, the relay will de-energize



TIMING DIAGRAM:



CONTACT INFORMATION

- Arrangement: 2 form C (DPDT)
- Contact material: Gold Clad Silver Alloy
- Rating: Maximum Switching Power - 1000 VA, 90W
- (Resistive); Maximum Switching Voltage - 250V AC, 48V DC
- Maximum Switching Current - 4 Amperes
- Nominal Switching Capacity - 4A 250V AC, 3A 30V DC
- UL/CSA Rating - 4 A 1/20 HP 125, 250V AC, 3A 30V DC
- Expected Life @ 25°C
 - Mechanical: 100 Million operations
 - Electrical 100,000 operation at 4A 250V AC
 - 200,000 operations at 3A 30V DC



ENVIRONMENTAL INFORMATION

temperature Range: Ambient: - 40°C to 65°C (-40° to +149°F)



OUTLINE DIMENSIONS

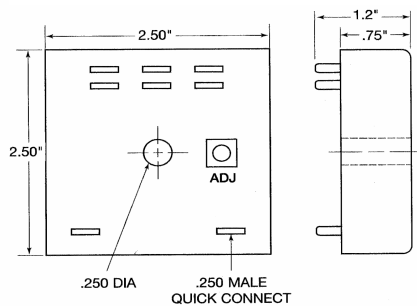



Solving your relay requirements since 1922

Amperite Co.

(800) 752-2329

www.Amperite.com



Timing Specifications

Fixed timing: 0.1 seconds to hour, tolerance 5%
consult factory for availability.

Adjustable Timing Ranges: .1 to 1 sec; 1 to 10 sec;
10 to 100 sec; 1 to 10 min; 10 to 100 min.

Availability of long delay time depends upon voltage;
consult factory for details.



INITIAL DIELECTRIC STRENGTH:

Between open contacts: 750V RMS

Between adjacent contacts: 1000V RMS

Between contacts & coil: 1500V RMS



INPUT INFORMATION

Voltage: 12, 24, 48, 120 volts AC or DC

Custom voltages are available

Power requirements: 2 VA or Watts

Transient: protection: 1 Joule MOV

Polarity protection DC units



INPUT VOLTAGES & LIMITS:

Nominal	Minimum	Maximum
10V	11V	15V
24V	20V	28V
48V	20V	28V
110V	41V	55V
120V	95V	125V



WRING DIAGRAM

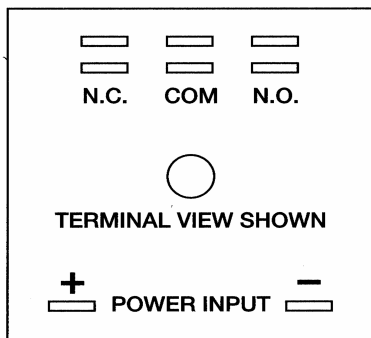

MECHANICAL INFORMATION

Termination: 1/4 inch quick-connect male terminals

Enclosure: 2 1/2 by 3/4 inch, epoxy sealed

Single 1/4 inch hole flat panel mounting.



Solving your relay requirements since 1922

Amperite Co.

(800) 752-2329
www.Amperite.com



Ordering Information

Definition of a part number for the Amperite

HDOD Series Time Delay Relay

Example:

120 A 1 - 10 M HDOD
↑ ↑ ↑ ↑ ↑ ↑
A B C D E F

- A: Denotes nominal input voltage. Voltages: 12, 24 and 120V AC; 12, 24, 48, and 110V DC.
- B: Denotes type of input power: A = AC, D = DC
- C & D: Denotes timing range if knob adjustability. See Standard ranges. For fixed units specify a single number. Costume timing available.
- E: Denotes unit of time delay: S = seconds; M = minutes
H = hours
- F: Denotes Amperite HDOD Series DPDT 4 ampere delay-on-dropout TDR.