



**MICROCHIP**

---

**MRF89XAM8A**  
**Data Sheet**

868 MHz Ultra-Low Power  
Sub-GHz Transceiver Module

---

**Note the following details of the code protection feature on Microchip devices:**

- Microchip products meet the specification contained in their particular Microchip Data Sheet.
- Microchip believes that its family of products is one of the most secure families of its kind on the market today, when used in the intended manner and under normal conditions.
- There are dishonest and possibly illegal methods used to breach the code protection feature. All of these methods, to our knowledge, require using the Microchip products in a manner outside the operating specifications contained in Microchip's Data Sheets. Most likely, the person doing so is engaged in theft of intellectual property.
- Microchip is willing to work with the customer who is concerned about the integrity of their code.
- Neither Microchip nor any other semiconductor manufacturer can guarantee the security of their code. Code protection does not mean that we are guaranteeing the product as "unbreakable."

Code protection is constantly evolving. We at Microchip are committed to continuously improving the code protection features of our products. Attempts to break Microchip's code protection feature may be a violation of the Digital Millennium Copyright Act. If such acts allow unauthorized access to your software or other copyrighted work, you may have a right to sue for relief under that Act.

---

Information contained in this publication regarding device applications and the like is provided only for your convenience and may be superseded by updates. It is your responsibility to ensure that your application meets with your specifications. MICROCHIP MAKES NO REPRESENTATIONS OR WARRANTIES OF ANY KIND WHETHER EXPRESS OR IMPLIED, WRITTEN OR ORAL, STATUTORY OR OTHERWISE, RELATED TO THE INFORMATION, INCLUDING BUT NOT LIMITED TO ITS CONDITION, QUALITY, PERFORMANCE, MERCHANTABILITY OR FITNESS FOR PURPOSE. Microchip disclaims all liability arising from this information and its use. Use of Microchip devices in life support and/or safety applications is entirely at the buyer's risk, and the buyer agrees to defend, indemnify and hold harmless Microchip from any and all damages, claims, suits, or expenses resulting from such use. No licenses are conveyed, implicitly or otherwise, under any Microchip intellectual property rights.

**Trademarks**

The Microchip name and logo, the Microchip logo, dsPIC, KEELOQ, KEELOQ logo, MPLAB, PIC, PICmicro, PICSTART, PIC<sup>32</sup> logo, rPIC and UNI/O are registered trademarks of Microchip Technology Incorporated in the U.S.A. and other countries.


FilterLab, Hampshire, HI-TECH C, Linear Active Thermistor, MXDEV, MXLAB, SEEVAL and The Embedded Control Solutions Company are registered trademarks of Microchip Technology Incorporated in the U.S.A.

Analog-for-the-Digital Age, Application Maestro, CodeGuard, dsPICDEM, dsPICDEM.net, dsPICworks, dsSPEAK, ECAN, ECONOMONITOR, FanSense, HI-TIDE, In-Circuit Serial Programming, ICSP, Mindi, MiWi, MPASM, MPLAB Certified logo, MPLIB, MPLINK, mTouch, Octopus, Omniscient Code Generation, PICC, PICC-18, PICDEM, PICDEM.net, PICKit, PICtail, REAL ICE, rLAB, Select Mode, Total Endurance, TSHARC, UniWinDriver, WiperLock and ZENA are trademarks of Microchip Technology Incorporated in the U.S.A. and other countries.

SQTP is a service mark of Microchip Technology Incorporated in the U.S.A.

All other trademarks mentioned herein are property of their respective companies.

© 2010, Microchip Technology Incorporated, Printed in the U.S.A., All Rights Reserved.

 Printed on recycled paper.

ISBN: 978-1-60932-637-1

*Microchip received ISO/TS-16949:2002 certification for its worldwide headquarters, design and wafer fabrication facilities in Chandler and Tempe, Arizona; Gresham, Oregon and design centers in California and India. The Company's quality system processes and procedures are for its PIC<sup>®</sup> MCUs and dsPIC<sup>®</sup> DSCs, KEELOQ<sup>®</sup> code hopping devices, Serial EEPROMs, microperipherals, nonvolatile memory and analog products. In addition, Microchip's quality system for the design and manufacture of development systems is ISO 9001:2000 certified.*

**QUALITY MANAGEMENT SYSTEM  
CERTIFIED BY DNV  
== ISO/TS 16949:2002 ==**

## 868 MHz Ultra-Low Power Sub-GHz Transceiver Module

### Features

- Module designed from the MRF89XA integrated ultra low-power, sub-GHz transceiver IC.
- Supports proprietary sub-GHz wireless protocols
- Simple, SPI Interface with Interrupts
- Small size: 0.7" x 1.1" (17.8 mm x 27.9 mm), surface mountable
- Integrated crystal, internal voltage regulator, matching circuitry and Printed Circuit Board (PCB) antenna
- Easy integration into final product: minimize product development, quicker time to market
- Compatible with Microchip's Microcontroller families (PIC16, PIC18, PIC24, dsPIC33 and PIC32)
- Conforms to the following ETSI standards:
  - EN 300 220-2 V2.3.1 (2001–02)
  - EN 301 489-3 V1.4.1 (2002–08)

### Operational

- Operating voltage: 2.1–3.6V (3.3V typical)
- Temperature range: -40°C to +85°C Industrial
- Low-current consumption:
  - Rx mode: 3 mA (typical)
  - Tx mode: 25 mA at +10 dBm (typical)
  - Sleep: 0.1  $\mu$ A (typical)

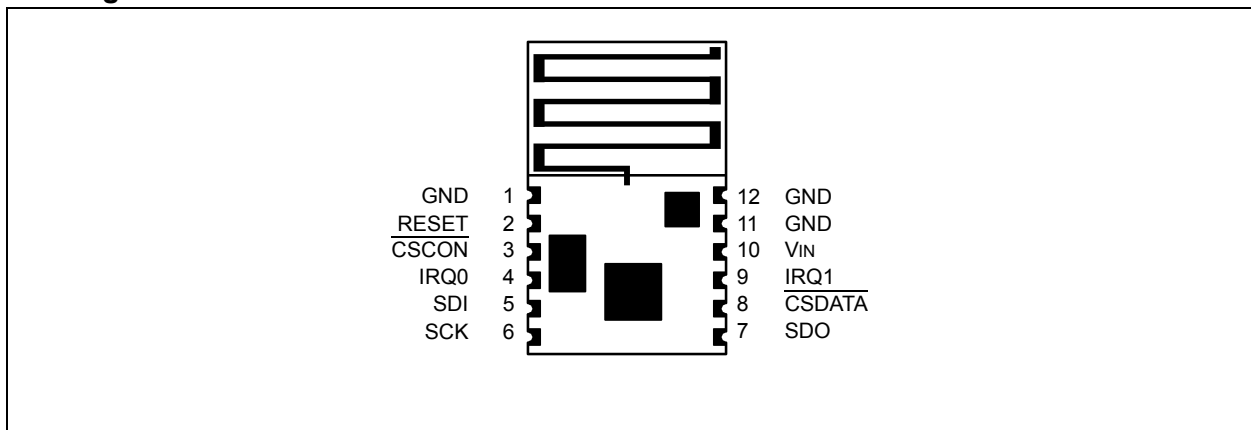
### RF/Analog Features

- 863–870 MHz operation
- Modulation: FSK and OOK
- Data rate (to conform to ETSI standards):
  - FSK: 40 kbps
  - OOK: 16 kbps
- Reception sensitivity
  - FSK: -107 dBm (typical) at 25 kbps
  - OOK: -113 dBm (typical) at 2 kbps
- +10 dBm typical output power with 21 dB Tx power control range

### Media Access Controller (MAC)/Baseband Features

- Packet handling features with data whitening and automatic CRC generation
- Incoming sync word (pattern) recognition
- Built-in bit synchronizer for incoming data, and clock synchronization and recovery
- 64-byte transmit/receive FIFO with preload in stand-by mode
- Supports Manchester encoding/decoding techniques

### Pin diagram



# MRF89XAM8A

---

## Table of Contents

.0	Device Overview .....	3
2.0	Circuit Description .....	9
3.0	Regulatory Approval .....	19
4.0	Electrical Characteristics .....	21
	Appendix A: Revision History .....	27
	The Microchip Web Site .....	29
	Customer Change Notification Service .....	29
	Customer Support .....	29
	Reader Response .....	30
	Product Identification System .....	31

## TO OUR VALUED CUSTOMERS

It is our intention to provide our valued customers with the best documentation possible to ensure successful use of your Microchip products. To this end, we will continue to improve our publications to better suit your needs. Our publications will be refined and enhanced as new volumes and updates are introduced.

If you have any questions or comments regarding this publication, please contact the Marketing Communications Department via E-mail at [docerrors@microchip.com](mailto:docerrors@microchip.com) or fax the **Reader Response Form** in the back of this data sheet to (480) 792-4150. We welcome your feedback.

### Most Current Data Sheet

To obtain the most up-to-date version of this data sheet, please register at our Worldwide Web site at:

<http://www.microchip.com>

You can determine the version of a data sheet by examining its literature number found on the bottom outside corner of any page. The last character of the literature number is the version number, (e.g., DS30000A is version A of document DS30000).

### Errata

An errata sheet, describing minor operational differences from the data sheet and recommended workarounds, may exist for current devices. As device/documentation issues become known to us, we will publish an errata sheet. The errata will specify the revision of silicon and revision of document to which it applies.

To determine if an errata sheet exists for a particular device, please check with one of the following:

- Microchip's Worldwide Web site; <http://www.microchip.com>
- Your local Microchip sales office (see last page)

When contacting a sales office, please specify which device, revision of silicon and data sheet (include literature number) you are using.

### Customer Notification System

Register on our web site at [www.microchip.com](http://www.microchip.com) to receive the most current information on all of our products.

## 1.0 DEVICE OVERVIEW

The MRF89XAM8A is an ultra-low power sub-GHz surface mount transceiver module with integrated crystal, internal voltage regulator, matching circuitry and PCB antenna. The MRF89XAM8A module operates in the European 863–870 MHz frequency band and is ETSI compliant. The integrated module design frees the integrator from the extensive RF and antenna design, and regulatory compliance testing, allowing quicker time to market.

The MRF89XAM8A module is compatible with Microchip's MiWi™ Development Environment software stacks. The software stacks are available as a free download, including source code, from the Microchip's web site <http://www.microchip.com/wireless>.

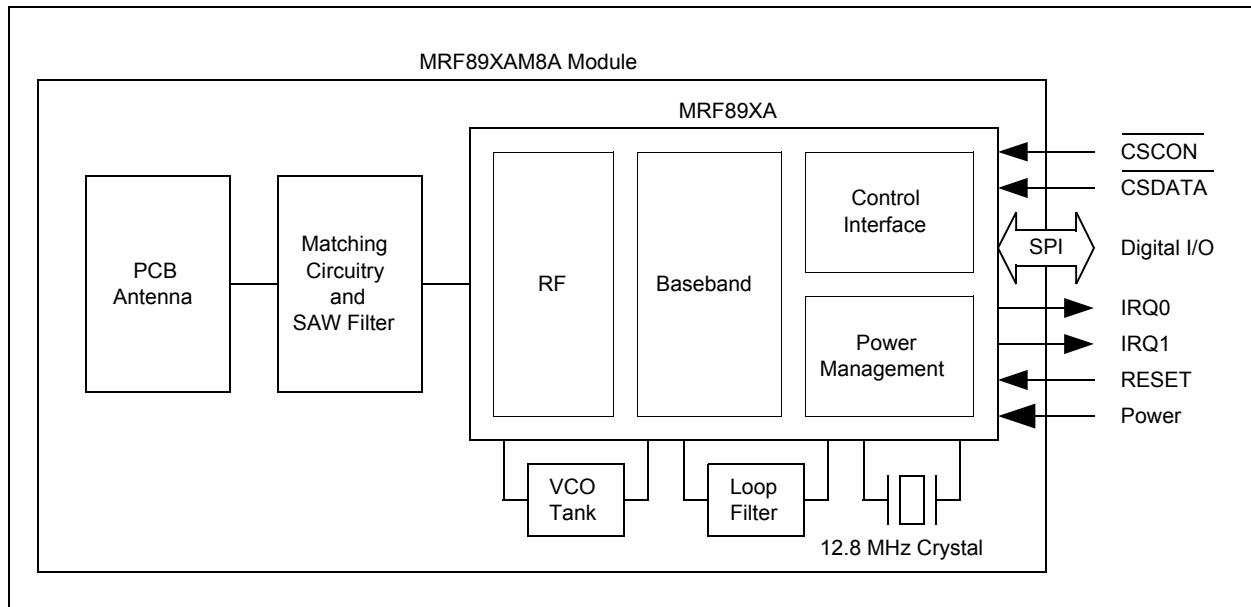
The MRF89XAM8A module has been tested and conforms to EN 300 220-2 V2.3.1 (2001–02) and EN 301 489-3 V1.4.1 (2002–08) European Standards. The module tests can be applied toward final product certification and Declaration of Conformity (DoC). To maintain conformance, refer to module settings in [Section 1.3, Operation](#). Additional testing may be required depending on the end application.

## 1.1 Interface description

The simplified block diagram of the MRF89XAM8A module is illustrated in [Figure 1-1](#). The module is based on the Microchip Technology MRF89XA ultra-low power sub-GHz transceiver Integrated Circuit (IC). The module interfaces to many popular Microchip PIC® microcontrollers through a 3-wire serial SPI interface, two chip selects (configuration and data), two interrupts Interrupt Request 0 (IRQ0) and Interrupt Request 1 (IRQ1), Reset, power and ground as illustrated in [Figure 1-2](#). [Table 1-1](#) provides the related pin descriptions.

Serial communication and module configuration are documented in the “*MRF89XA Ultra-Low Power, Integrated Sub-GHz Transceiver*” (DS70622) Data Sheet. Refer to the “*MRF89XA Data Sheet*” for specific serial interface protocol and general register definitions. Also, see [Section 1.3, Operation](#) for specific register settings that are unique to the MRF89XAM8A module operation to maintain regulatory compliance.

**FIGURE 1-1: MRF89XAM8A BLOCK DIAGRAM**

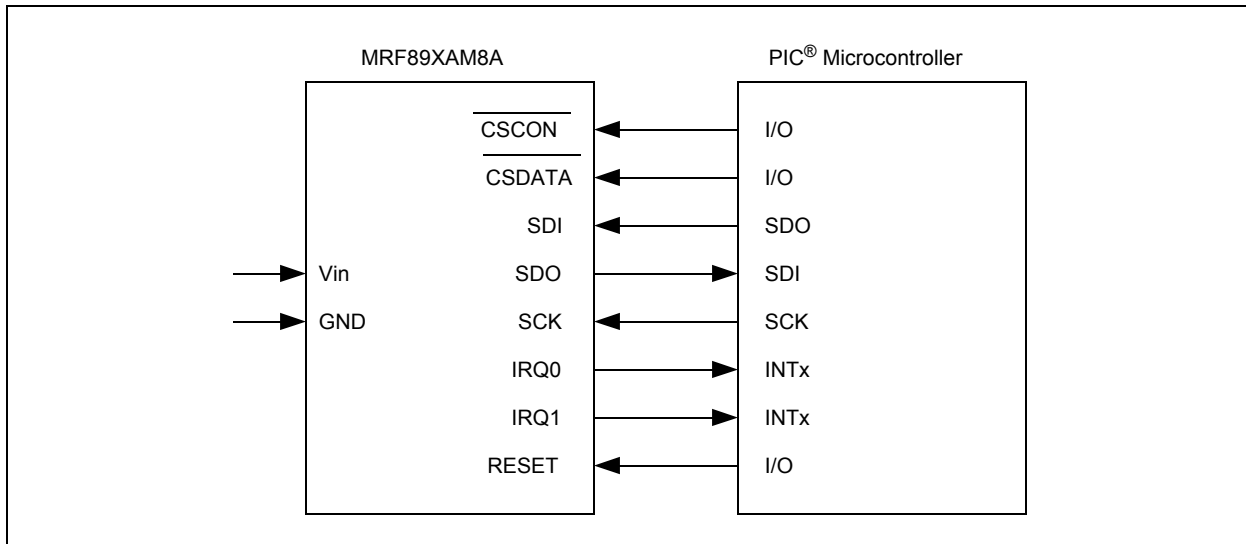


# MRF89XAM8A

**TABLE 1-1: PIN DESCRIPTION**

Pin	Symbol	Type	Description
1	GND	Power	Ground
2	RESET	DI	Reset Pin
3	CSCON	DI	Serial Interface Configure Chip Select
4	IRQ0	DO	Interrupt Request Output
5	SDI	DI	Serial Interface Data Input
6	SCK	DI	Serial Interface Clock
7	SDO	DO	Serial Interface Data Output
8	CSDATA	DI	Serial Interface Data Chip Select
9	IRQ1	DO	Interrupt Request Output
10	Vin	Power	Power Supply
11	GND	Power	Ground
12	GND	Power	Ground

**FIGURE 1-2: MICROCONTROLLER TO MRF89XAM8A INTERFACE**

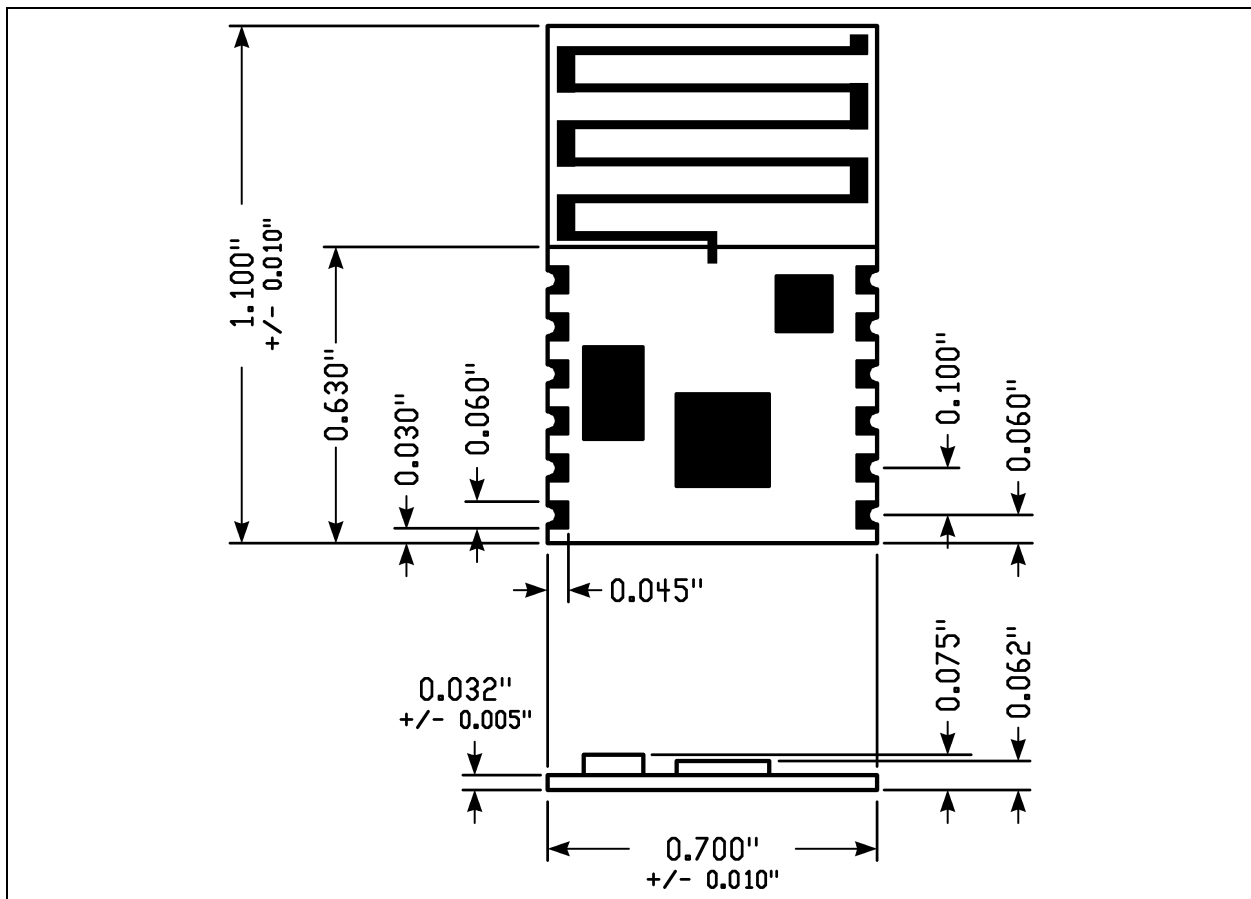


## 1.2 Mounting Details

The MRF89XAM8A is a surface mountable module, the module dimensions are illustrated in Figure 1-3. The module PCB is 0.032" thick with castellated mounting holes on the edge. Figure 1-4 is the recommended host PCB footprint for the MRF89XAM8A.

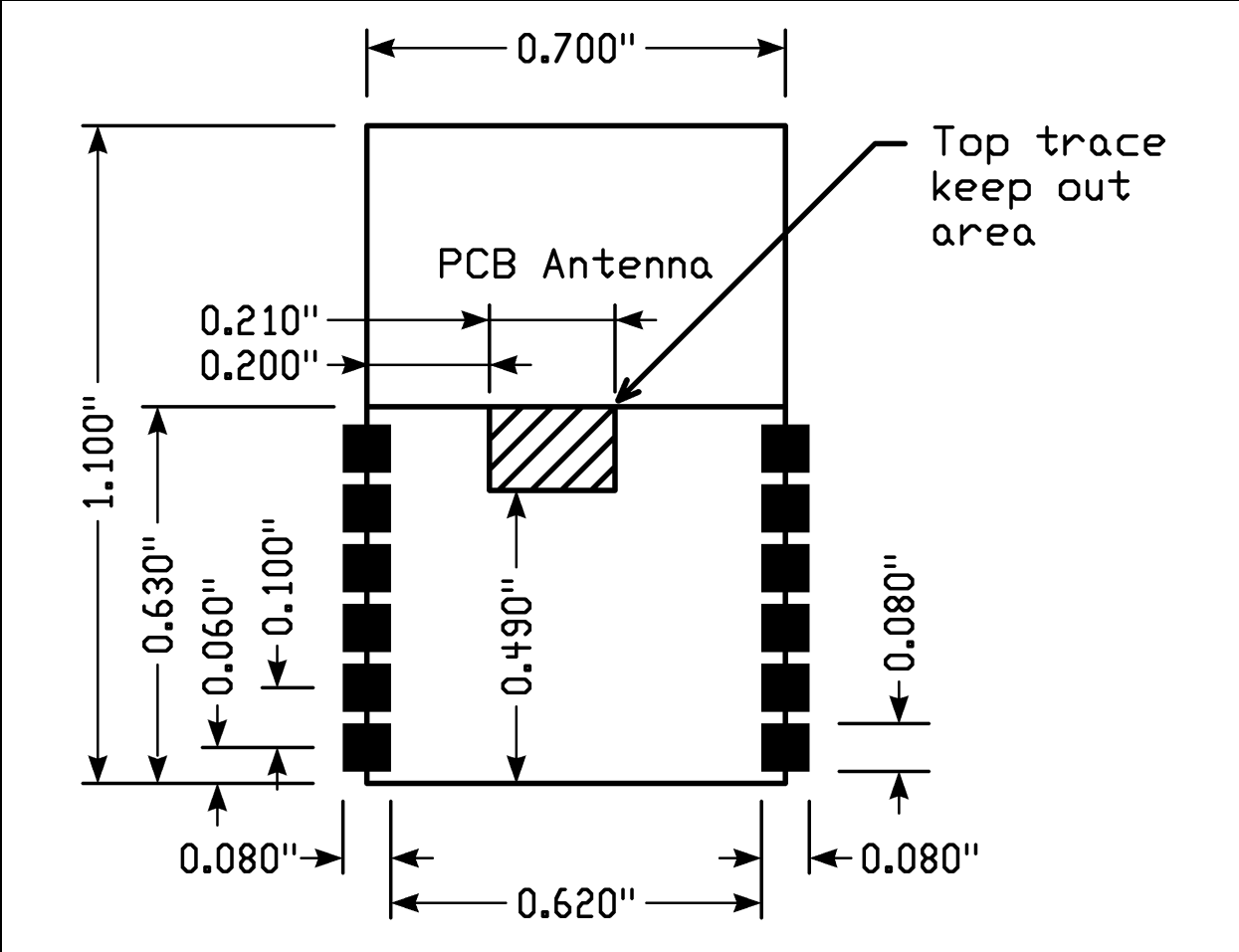
The MRF89XAM8A has an integrated PCB antenna. For the best performance, follow the mounting details as illustrated in Figure 1-5. It is recommended that the module be mounted on the edge of the host PCB and an area around the antenna, approximately 3.4" (8.6 cm), be kept clear of metal objects for best performance. A host PCB ground plane around the MRF89XAM8A acts as a counterpoise to the PCB antenna. Extend the host PCB top copper ground plane under and to the left and right side of the module at least 0.4 inches (1 cm) for best antenna performance.

**FIGURE 1-3: MODULE DETAILS**



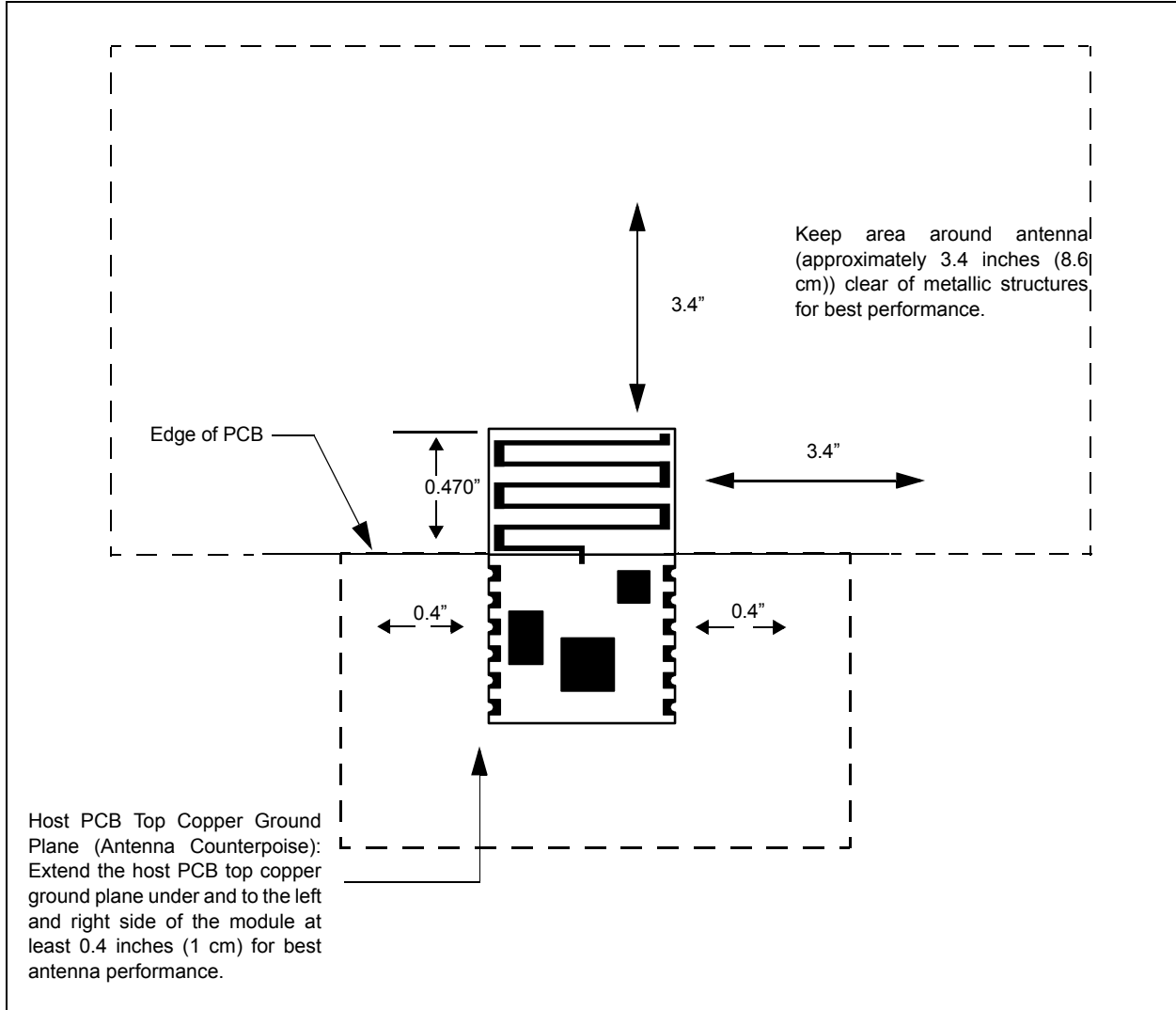
# MRF89XAM8A

FIGURE 1-4: RECOMMENDED PCB FOOTPRINT





**FIGURE 1-5: MOUNTING DETAILS**



# MRF89XAM8A

---

## 1.3 Operation

The MRF89XAM8A module is based on the Microchip Technology MRF89XA ultra-low power, integrated ISM band sub-GHz transceiver IC. Serial communication and module configuration are documented in the “MRF89XA Ultra-Low Power, Integrated ISM Band Sub-GHz Transceiver Data Sheet” (DS70622).

This section emphasizes operational settings that are unique to the MRF89XAM8A module design that must be followed in order for the module to conform to the tested European standards summarized in [Section 3.0, Regulatory Approval](#).

<p><b>Note:</b> To maintain conformance to tested ETSI standards, the module shall not be modified and settings in <a href="#">Section 1.3, Operation</a> must be observed.</p>
---

### 1.3.1 RESET

Pin 2 of the module, RESET, enables an external reset of the MRF89XA IC. RESET is connected to the TEST8 pin of the MRF89XA IC. During normal operations of the MRF89XAM8A, the RESET pin should be held in a high impedance state. For more information on assertion of the RESET pin, refer to “[Section 3.1.2 Manual Reset](#)” of “[MRF89XA Data Sheet](#)” (DS70622).

### 1.3.2 CRYSTAL FREQUENCY

When calculating frequency deviation, bit rate, receiver bandwidth, and PLL R, P and S values, use crystal frequency  $f_{xtal} = 12.8$  MHz.

### 1.3.3 CLOCK OUTPUT (CLKOUT)

The CLKOUT pin 19 of the MRF89XA IC is not used on the module. Ensure that the CLKOUT signal is disabled to minimize current consumption.

### 1.3.4 FREQUENCY SHIFT KEYING MODULATION (FSK)

The following settings must be followed for FSK modulation mode to conform to the European standards summarized in [Section 3.0, Regulatory Approval](#).

- Bit Rate Maximum Setting: 40 kbps
- Frequency Deviation Maximum Setting: 40 kHz
- Transmit Bandwidth Maximum Setting: 125 kHz
- Lower Frequency Setting: 863.5 MHz
- Upper Frequency Setting: 869.5 MHz

### 1.3.5 ON-OFF KEYING MODULATION (OOK)

The following settings must be followed for OOK modulation mode to conform to the European standards summarized in [Section 3.0, Regulatory Approval](#).

- Bit Rate Maximum Setting: 16 kbps
- Frequency Deviation Maximum Setting: 80 kHz
- Transmit Bandwidth Maximum Setting: 125 kHz
- Lower Frequency Setting: 863.5 MHz
- Upper Frequency Setting: 869.5 MHz

## 2.0 CIRCUIT DESCRIPTION

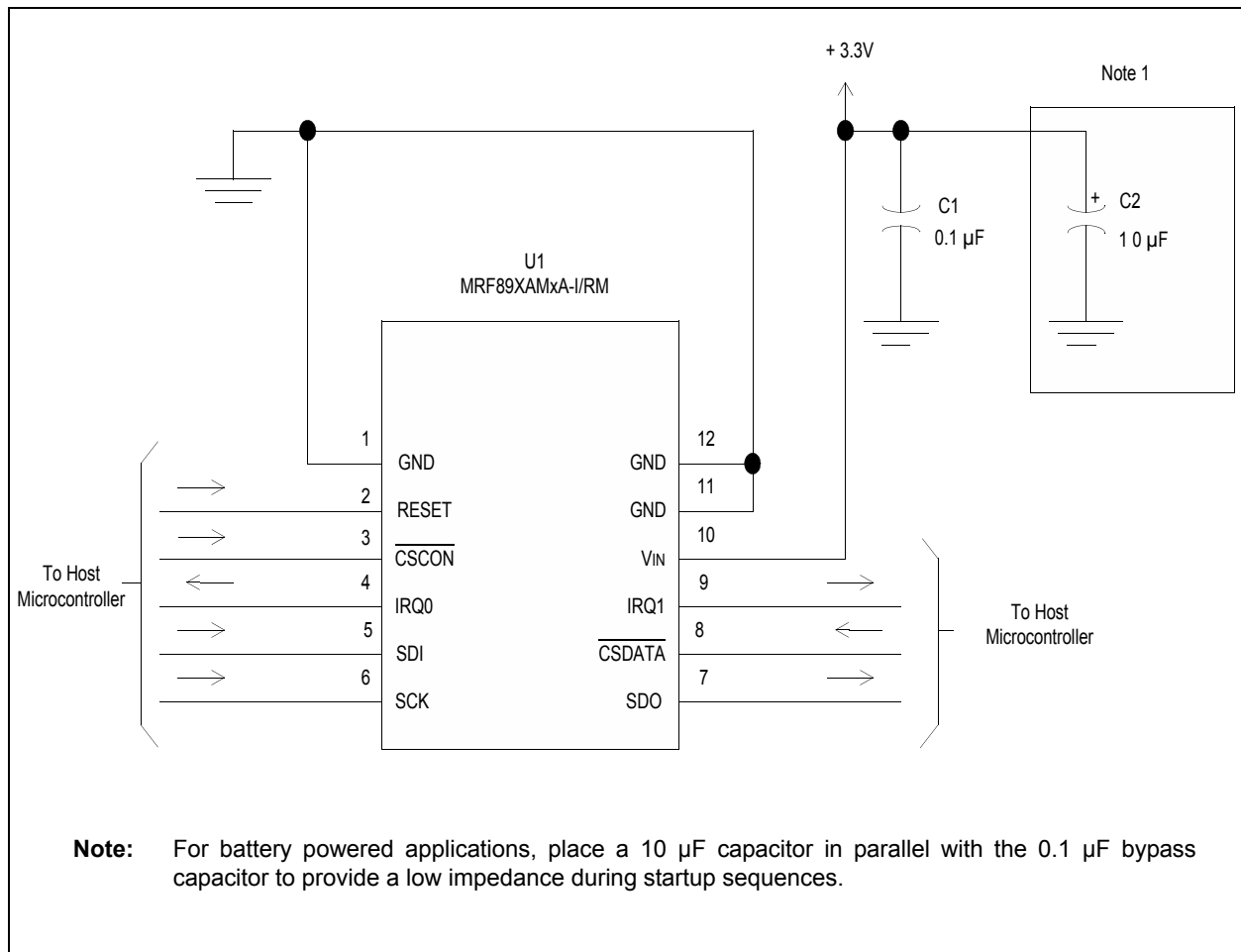
The MRF89XAM8A module interfaces to Microchip's PIC16, PIC18, PIC24, dsPIC33 and PIC32 microcontrollers with a minimum of external components through digital only connections. An example application schematic is illustrated in Figure 2-1.

Figure 2-2 illustrates the MRF89XAM8A schematics. Table 2-1 details the Bill of Materials (BOM).

## 2.1 Module Schematic

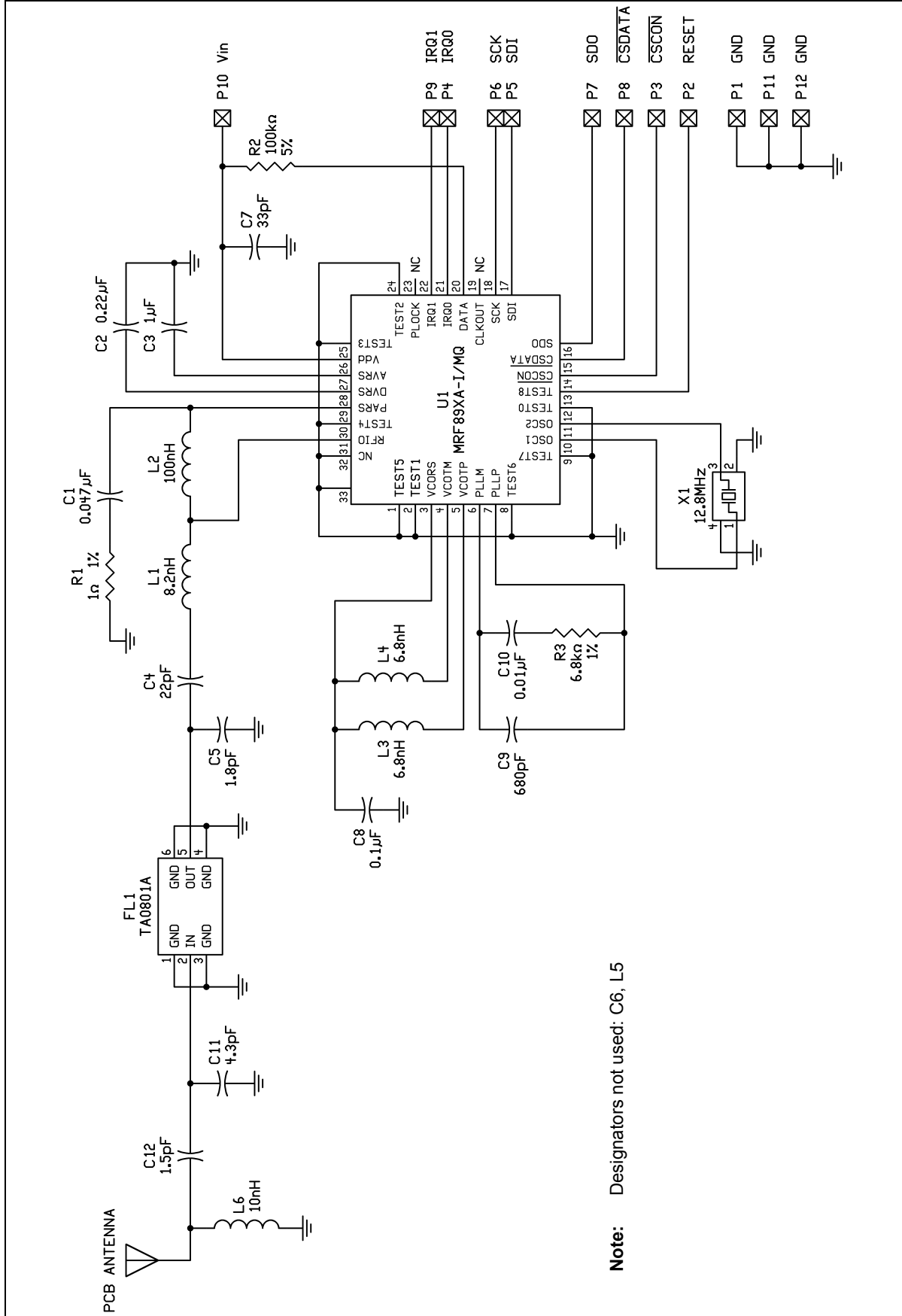
The MRF89XAM8A module is based on the Microchip Technology MRF89XA Ultra-Low Power, Integrated ISM Band sub-GHz Transceiver IC. The serial I/O (CSCON, CSDATA, SCK, SDO and SDI), RESET, IRQ0 and IRQ1 pins are brought to the module pins. Crystal X1 is a 12.8 MHz crystal with a frequency tolerance of  $\pm 10$  ppm at 25°C. The RFIO output is matched to the SAW filter FL1 and further matched to the PCB trace antenna.

**FIGURE 2-1: MRF89XAM8A APPLICATION SCHEMATIC**



# MRF89XAM8A

FIGURE 2-2: MRF89XAM8A SCHEMATIC



# MRF89XAM8A

**TABLE 2-1: MRF89XAM8A BILL OF MATERIALS**

Designator	Value	Description	Manufacturer	Part Number
C1	0.047 $\mu$ F	Capacitor, Ceramic, 10V, $\pm$ 10%, X7R, SMT 0402	Murata	GRM155R71A473KA01D
C2	0.22 $\mu$ F	Capacitor, Ceramic, 16V, $\pm$ 10%, X7R, SMT 0402	Murata	GRM155R71C224KA12D
C3	1 $\mu$ F	Capacitor, Ceramic, 6.3V, $\pm$ 10%, X5R, SMT 0603	Murata	GRM188R60J105KA01D
C4	22 pF	Capacitor, Ceramic, 50V, $\pm$ 5%, UHI-Q NP0, SMT 0402	Johanson Technology	500R07S220JV4
C5	1.8 pF	Capacitor, Ceramic, 50V, $\pm$ 0.1 pF, UHI-Q NP0, SMT 0402	Johanson Technology	500R07S1R8BV4
C6	—	Designator not used	—	—
C7	33 pF	Capacitor, Ceramic, 50V, $\pm$ 5%, C0G, SMT 0402	Murata	GRM1555C1H330JZ01D
C8	0.1 $\mu$ F	Capacitor, Ceramic, 16V, $\pm$ 10%, X7R, SMT 0402	Murata	GRM155R71C104KA88D
C9	680 pF	Capacitor, Ceramic, 50V, $\pm$ 5%, C0G, SMT 0402	Murata	GRM1555C1H681JA01D
C10	0.01 $\mu$ F	Capacitor, Ceramic, 16V, $\pm$ 10%, X7R, SMT 0402	Murata	GRM155R71C103KA01D
C11	4.3 pF	Capacitor, Ceramic, 50V, $\pm$ 0.1 pF, UHI-Q NP0, SMT 0402	Johanson Technology	500R07S4R3BV4
C12	1.5 pF	Capacitor, Ceramic, 50V, $\pm$ 0.1 pF, UHI-Q NP0, SMT 0402	Johanson Technology	500R07S1R5BV4
FL1	TA0801A	Filter, SAW, 863–870 MHz	Tai-saw Technology	TA0801A
L1	8.2 nH	Inductor, Ceramic, $\pm$ 5%, SMT 0402	Johanson Technology	L-07C8N2JV6T
L2	100 nH	Inductor, Ceramic, $\pm$ 5%, SMT 0402	Johanson Technology	L-07CR10JV6T
L3	6.8 nH	Inductor, Wirewound, $\pm$ 5%, SMT 0402	Johanson Technology	L-07W6N8JV4T
L4	6.8 nH	Inductor, Wirewound, $\pm$ 5%, SMT 0402	Johanson Technology	L-07W6N8JV4T
L5	—	Designator not used	—	—
L6	10 nH	Inductor, Ceramic, $\pm$ 5%, SMT 0402	Johanson Technology	L-07C10NV6T
R1	1 $\Omega$	Resistor, 1%, $\pm$ 100 ppm/ $^{\circ}$ C, SMT 0402	Vishay/Dale	CRCW04021R00FKE D
R2	100K $\Omega$	Resistor, 5%, $\pm$ 100 ppm/ $^{\circ}$ C, SMT 0402	Yageo	RC0402JR-07100KL
R3	6.8K $\Omega$	Resistor, 1%, $\pm$ 100 ppm/ $^{\circ}$ C, SMT 0402	Yageo	RC0402FR-076K8L
U1	MRF89XA	Transceiver, Ultra-Low Power, Integrated sub-GHz	Microchip Technology	MRF89XA-I/MQ
X1	12.8 MHz	Crystal, $\pm$ 10 ppm, 15 pF, ESR 100 ohms, SMT 5 x 3.2mm	Abracon	ABM3B-155-12.800M Hz-T

# MRF89XAM8A

## 2.2 Printed Circuit Board

The MRF89XAM8A module PCB is constructed with high temperature FR4 material, 4 layers and 0.032 inches thick. These layers are shown in Figure 2-3 through Figure 2-8. The stack up of the PCB is shown in Figure 2-9

FIGURE 2-3: TOP SILK SCREEN

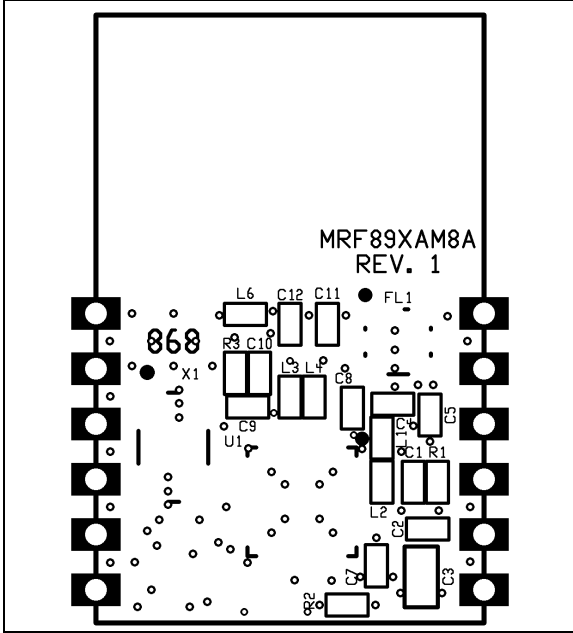


FIGURE 2-4: TOP COPPER

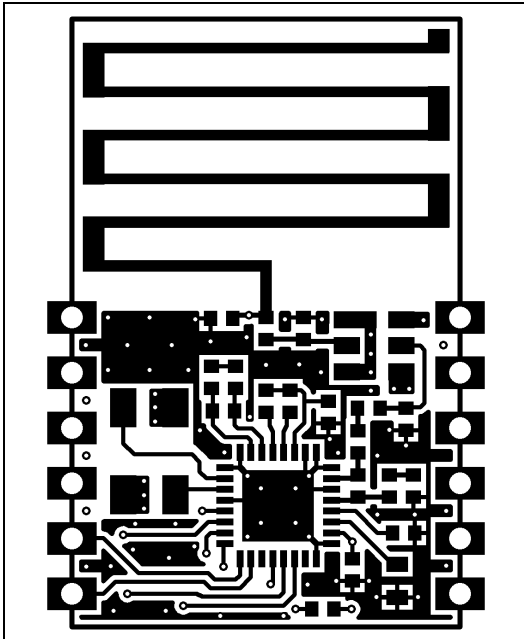


FIGURE 2-5: LAYER 2 — GROUND PLANE

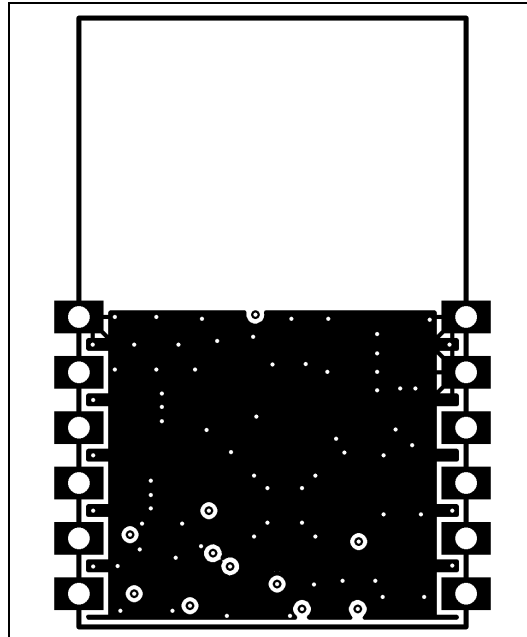


FIGURE 2-6: LAYER 3 — POWER PLANE

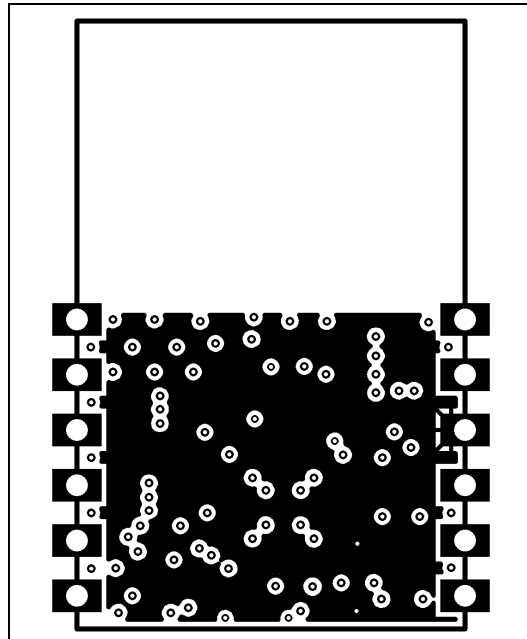


FIGURE 2-7: BOTTOM COPPER

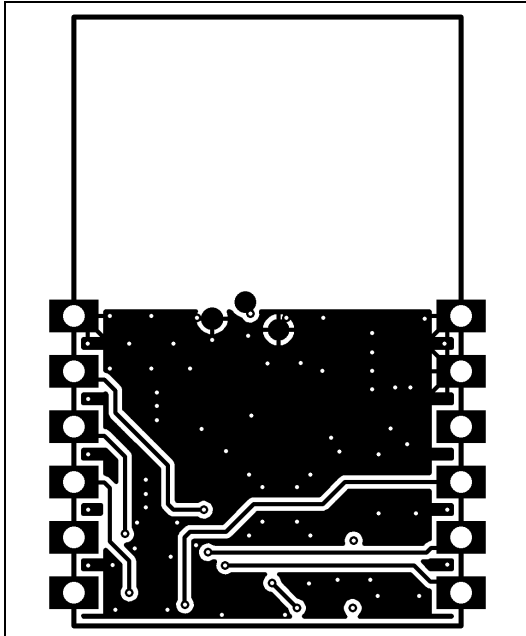
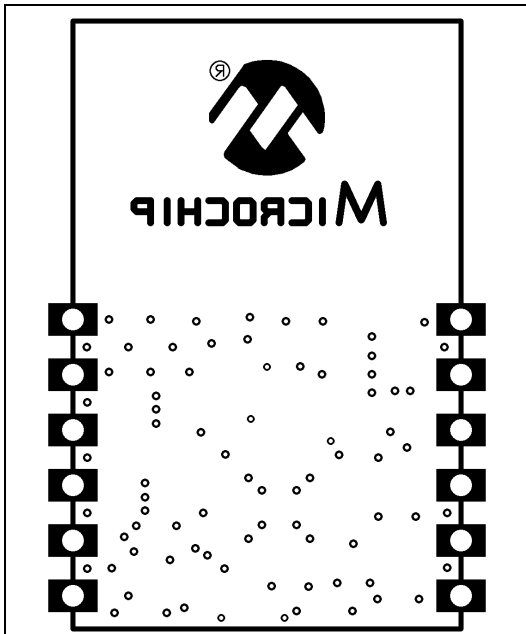
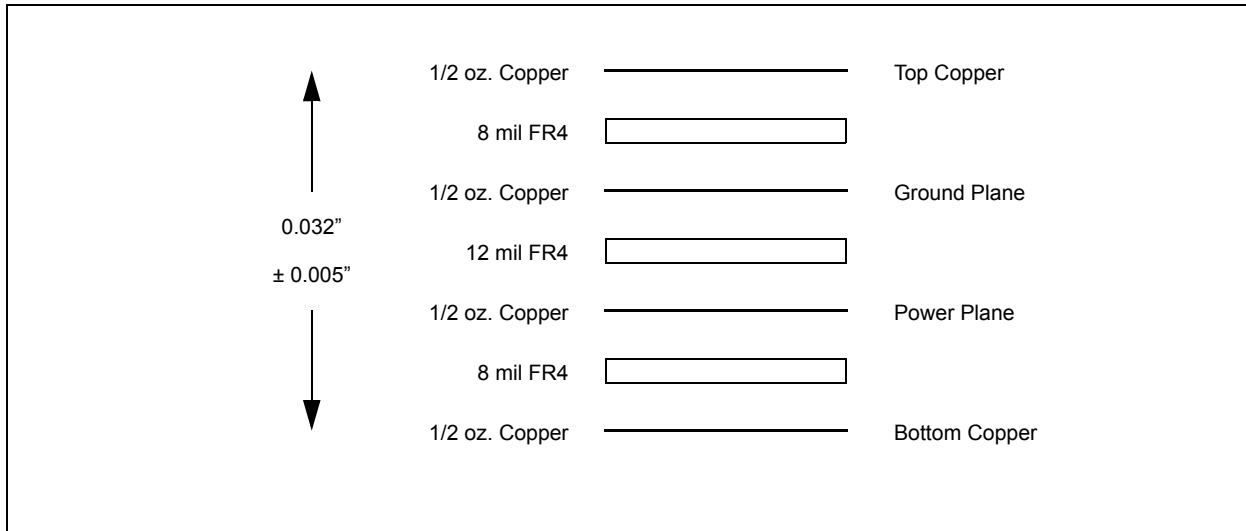


FIGURE 2-8: BOTTOM SILK SCREEN



# MRF89XAM8A

**FIGURE 2-9: PCB LAYER STACK UP**

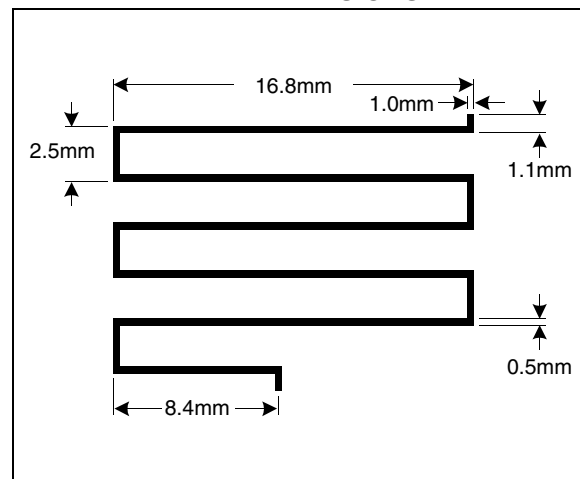


## 2.3 PCB Antenna

The PCB antenna is fabricated on the top copper trace. [Figure 2-10](#) illustrates the trace dimensions. The layers below the antenna have no copper traces. The ground and power planes under the components serve as a counterpoise to the PCB antenna. Additional ground plane on the host PCB will substantially enhance the performance of the module. For best performance, place the module on the host PCB by following the recommendations given in the [Section 1.2, Mounting Details](#).

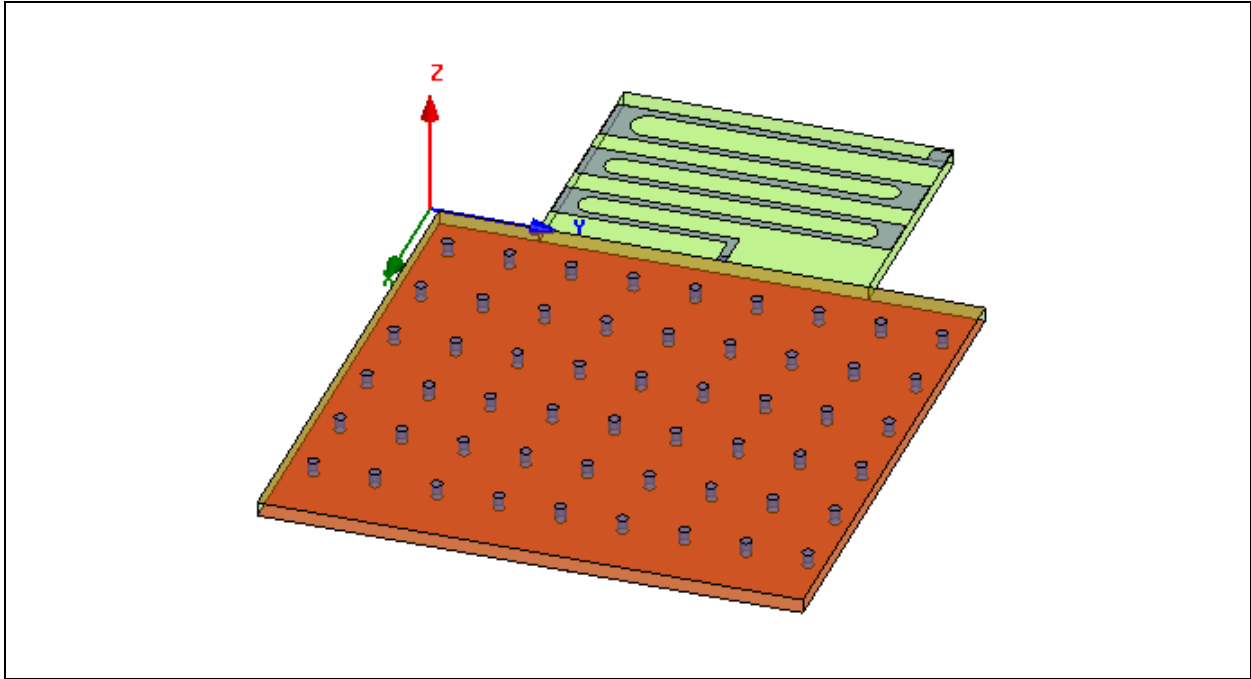
The PCB antenna was designed and simulated using Ansoft Designer® and HFSS™ 3D full-wave solver software by ANSYS Inc. ([www.ansoft.com](http://www.ansoft.com)). The goal of the design was to create a compact, low-cost antenna with the best radiation pattern. [Figure 2-11](#) illustrates the simulation drawing and [Figure 2-12](#) and [Figure 2-13](#) illustrates the 2D and 3D radiation patterns. As shown by the radiation patterns, the performance of the antenna is dependant upon the orientation of the module. [Figure 2-14](#) illustrates the impedance simulation and [Figure 2-15](#) illustrates the simulated PCB antenna VSWR. The discrete matching circuitry matches the impedance of the antenna with the SAW filter and MRF89XA transceiver IC.

**FIGURE 2-10: PCB ANTENNA DIMENSIONS**

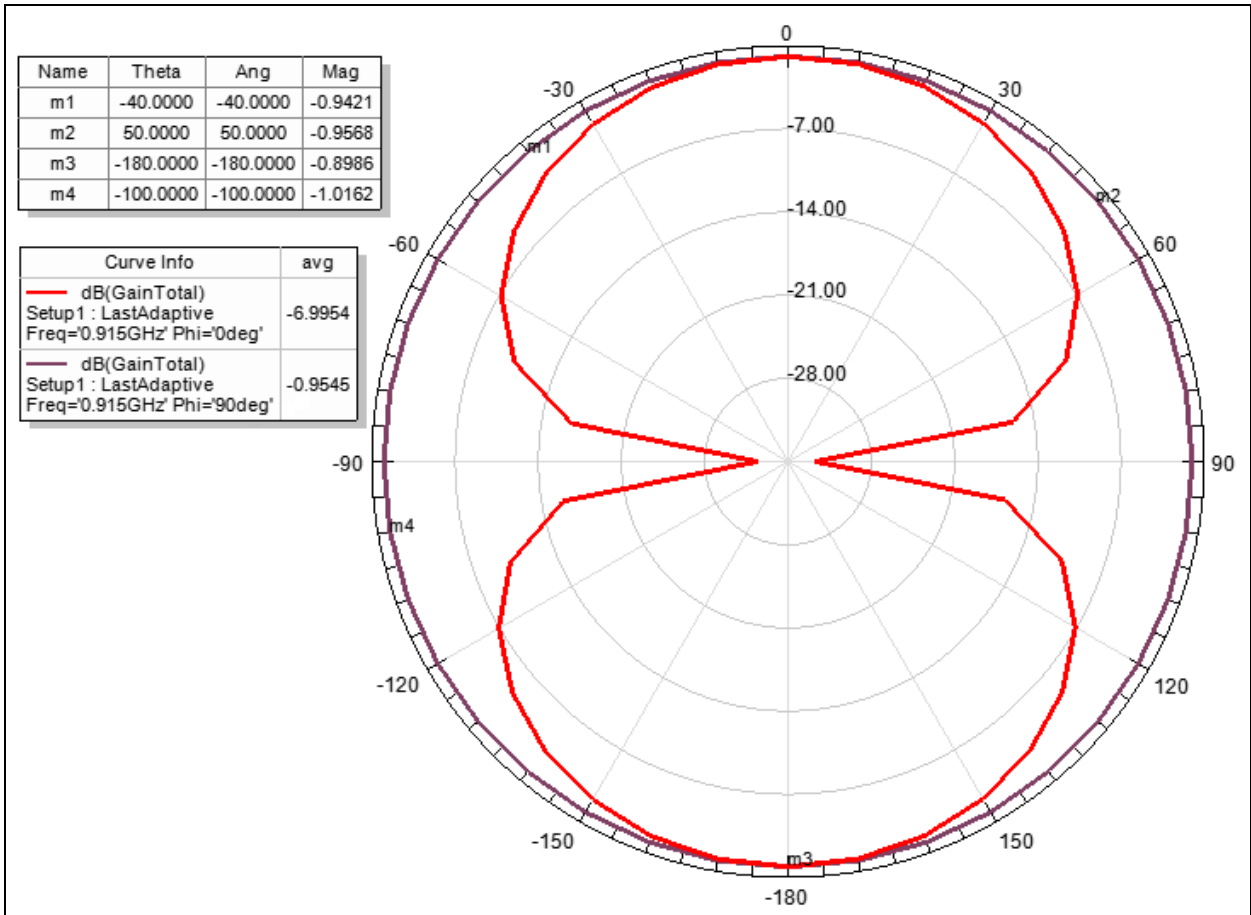




**FIGURE 2-11: PCB ANTENNA SIMULATION DRAWING**



**FIGURE 2-12: SIMULATED 2D RADIATION PATTERN**



# MRF89XAM8A

FIGURE 2-13: SIMULATED 3D RADIATION PATTERN

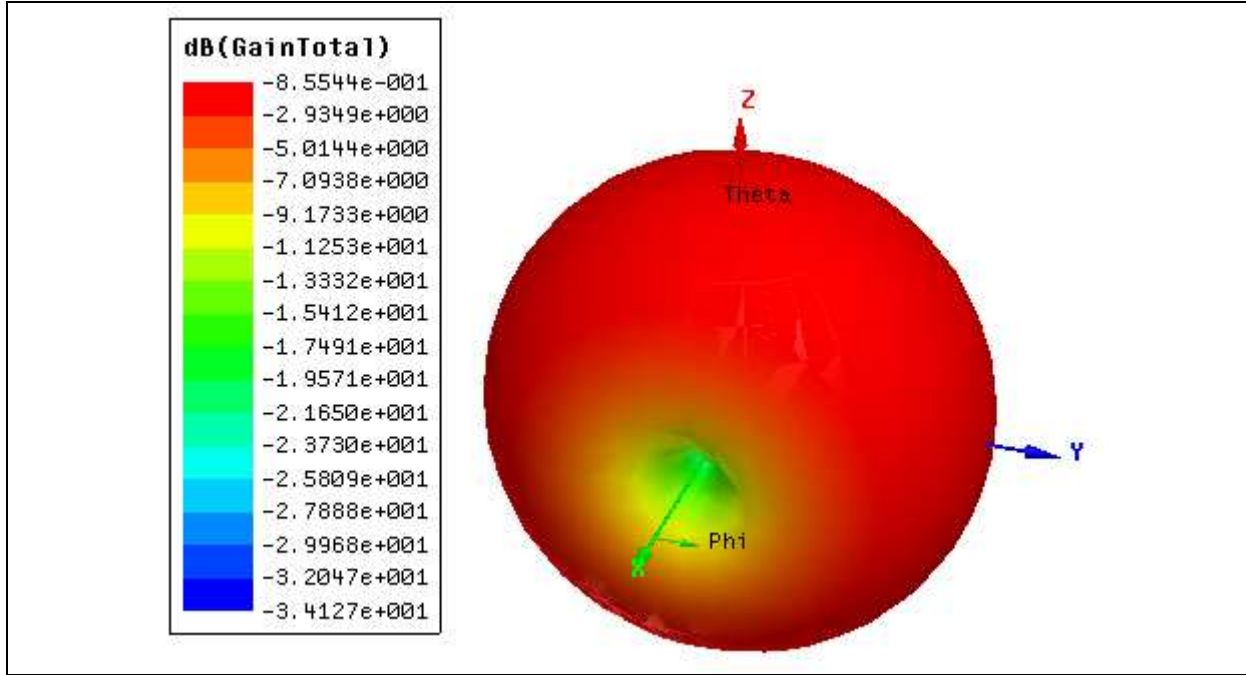
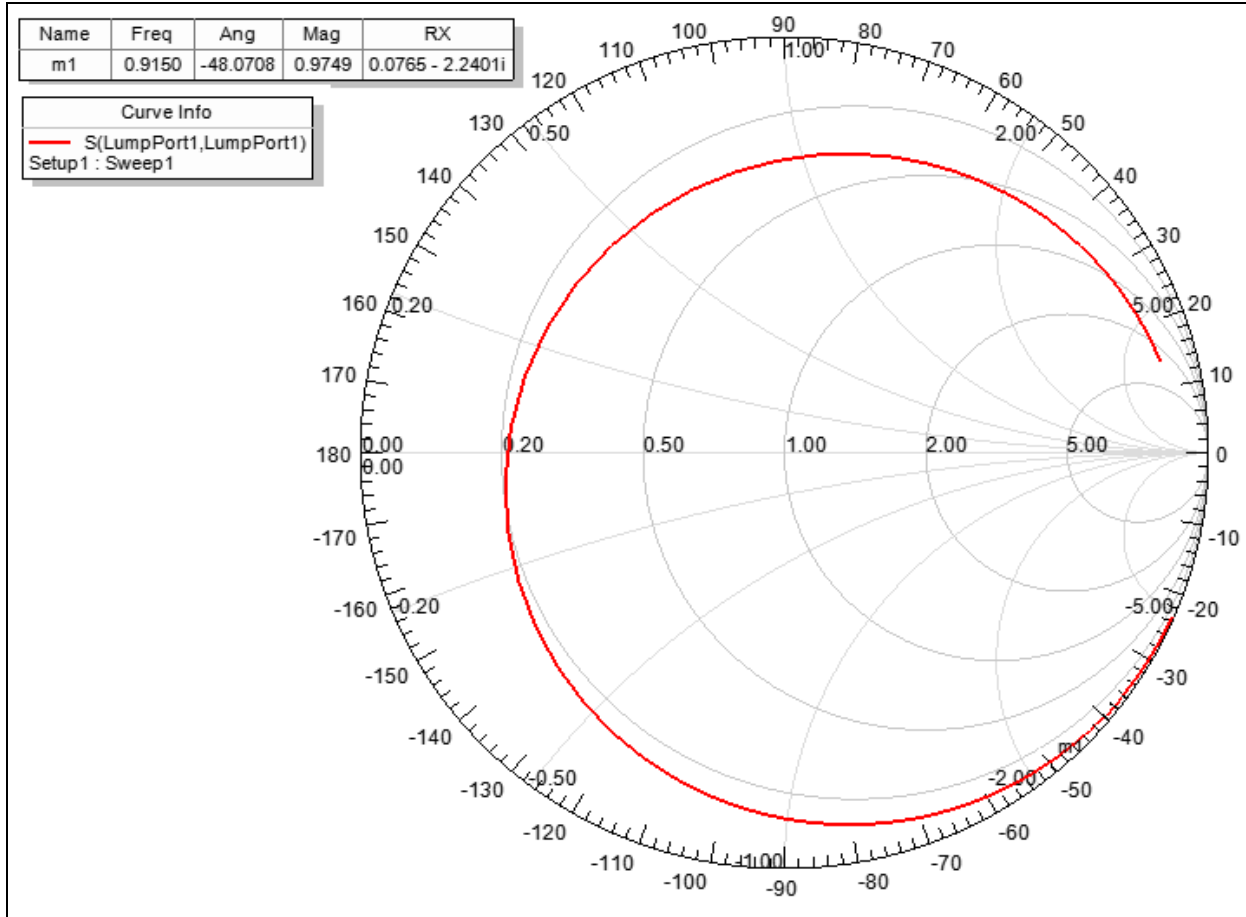
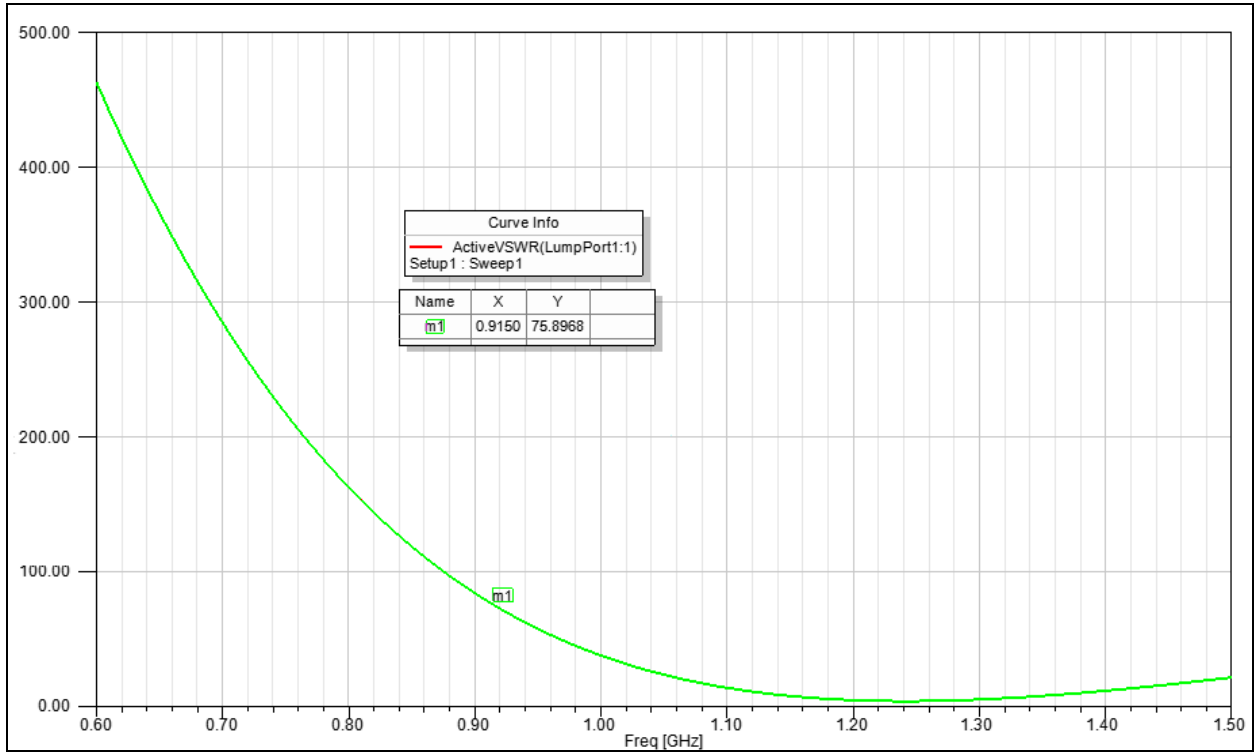


FIGURE 2-14: SIMULATED PCB ANTENNA IMPEDANCE



**FIGURE 2-15: SIMULATED PCB ANTENNA VSWR**



# MRF89XAM8A

---

NOTES:

## 3.0 REGULATORY APPROVAL

### 3.1 Europe

The MRF89XAM8A module conforms to the emission and immunity standards summarized in [Table 3-1](#). The module tests can be applied toward final product certification and DoC.

**Note:** To maintain conformance tested ETSI standards, the module shall not be modified and settings in [Section 1.3, Operation](#) must be observed.

The European Standards do not provide a modular approval similar to the USA (FCC) and Canada (IC). However, the completed compliance testing can be used as part of the customer's application for product certification. The module test report data can be included in the customer's product test plan and can significantly lower customer's certification burden.

Depending on the end application, additional testing may be required. The integrator is responsible for testing the end product for any additional compliance requirements that become necessary with this module installed (for example, digital device emission, PC peripheral requirements and so on) in the specific country where end device is marketed.

#### 3.1.1 HELPFUL WEB SITES

A helpful document that can be used as a starting point in understanding the use of Short Range Devices (SRD) in Europe is the European Radio Communications Committee (ERC) Recommendation 70-03 E, can be downloaded from the following websites:

- European Radio Communications Office (ERO): <http://www.ero.dk>.
- Radio and Telecommunications Terminal Equipment (R&TTE): [http://ec.europa.eu/enterprise/rtte/index\\_en.htm](http://ec.europa.eu/enterprise/rtte/index_en.htm)
- European Conference of Postal and Telecommunications Administrations (CEPT): <http://www.cept.org/>
- European Telecommunications Standards Institute (ETSI): <http://www.etsi.org/>

**TABLE 3-1: EMISSIONS AND IMMUNITY STANDARDS TESTED**

Specification			Test Method
<b>Emission Standards</b>			
EN 300 220-2 V2.3.1 (2001-02)	7.1.2	Frequency error and drift	5.1.3.1
EN 300 220-2 V2.3.1 (2001-02)	7.3.2	Effective Radiated Power	5.1.3.3
EN 300 220-2 V2.3.1 (2001-02)	7.5.2	Transient power	5.1.3.4
EN 300 220-2 V2.3.1 (2001-02)	7.7.2	Modulation bandwidth	5.1.3.6
EN 300 220-2 V2.3.1 (2001-02)	—	Unwanted emissions on the spurious domain	5.1.3.7
EN 300 220-2 V2.3.1 (2001-02)	8.6.4	Receiver spurious radiation	5.1.4.6
<b>Immunity Standards</b>			
EN 301 489-3 V1.4.1 (2002-08)	—	Conducted emissions	EN 55022:2007
EN 301 489-3 V1.4.1 (2002-08)	—	Radiated emissions	EN 55022:2007
EN 301 489-3 V1.4.1 (2002-08)	—	Radiated immunity	EN 61000-4-3

# MRF89XAM8A

---

NOTES:

## 4.0 ELECTRICAL CHARACTERISTICS

### Absolute Maximum Ratings

Ambient temperature under bias .....	-40°C to +85°C
Storage temperature .....	-55°C to +125°C
Voltage on VIN with respect to VSS .....	-0.3V to 6V
Voltage on any combined digital and analog pin with respect to VSS (except VIN) .....	-0.3V to (VIN + 0.3V)
Input current into pin (except VIN and VSS) .....	-25 mA to 25 mA
Electrostatic discharge with human body model .....	1000V

**NOTICE:** Stresses above those listed under “Absolute Maximum Ratings” may cause permanent damage to the device. This is a stress rating only and functional operation of the device at those or any other conditions above those indicated in the operation listings of this specification is not implied. Exposure to maximum rating conditions for extended periods may affect device reliability.

# MRF89XAM8A

**TABLE 4-1: RECOMMENDED OPERATING CONDITIONS**

Parameter	Min	Typ	Max	Unit	Condition
Ambient Operating Temperature	-40	—	+85	°C	—
Supply Voltage for RF, Analog and Digital Circuits	2.1	—	3.6	V	—
Supply Voltage for Digital I/O	2.1	—	3.6	V	—
Input High Voltage ( $V_{IH}$ )	$0.5 * V_{IN}$	—	$V_{IN} + 0.3$	V	—
Input Low Voltage ( $V_{IL}$ )	-0.3V	—	$0.2 * V_{IN}$	V	—
AC Peak Voltage on Open Collector Outputs (IO) <sup>(1)</sup>	$V_{IN} - 1.5$	—	$V_{IN} + 1.5$	V	—

**Note 1:** At minimum,  $V_{IN} - 1.5V$  should not be lower than 1.8V.

**TABLE 4-2: CURRENT CONSUMPTION**

Symbol	Chip Mode	Min	Typ	Max	Unit	Condition
IDDSL	Sleep	—	0.1	2	μA	Sleep clock disabled, all blocks disabled
IDDST	Idle	—	65	80	μA	Oscillator and baseband enabled
IDDFS	Frequency Synthesizer	—	1.3	1.7	mA	Frequency synthesizer running
IDDTX	Tx	—	25 16	30 21	mA mA	Output power = +10 dBm Output power = +1 dBm <sup>(1)</sup>
IDDRX	Rx	—	3.0	3.5	mA	—

**Note 1:** Guaranteed by design and characterization.

**TABLE 4-3: DIGITAL I/O PIN INPUT SPECIFICATIONS<sup>(1)</sup>**

Symbol	Characteristic	Min	Typ	Max	Unit	Condition
$V_{IL}$	Input Low Voltage	—	—	$0.2 * V_{IN}$	V	—
$V_{IH}$	Input High Voltage	$0.8 * V_{IN}$	—	—	V	—
$I_{IL}$	Input Low Leakage Current <sup>(2)</sup>	-0.5	—	0.5	μA	$V_{IL} = 0V$
$I_{IH}$	Input High Leakage Current	-0.5	—	0.5	μA	$V_{IH} = V_{IN}, V_{IN} = 3.7$
$V_{OL}$	Digital Low Output Voltage	—	—	$0.1 * V_{IN}$	—	$I_{OL} = 1 mA$
$V_{OH}$	Digital Low Output	$0.9 * V_{IN}$	—	—	V	$I_{OH} = -1 mA$

**Note 1:** Measurement Conditions:  $T_A = 25^\circ C$ ,  $V_{IN} = 3.3V$ , Crystal Frequency = 12.8 MHz, unless otherwise specified.

**2:** Negative current is defined as the current sourced by the pin.



**TABLE 4-4: PLL PARAMETERS AC CHARACTERISTICS<sup>(1)</sup>**

Symbol	Parameter	Min	Typ	Max	Unit	Condition
FRO	Frequency Ranges	863	—	870	MHz	
BRFSK	Bit Rate (FSK)	1.56	—	40	kbps	NRZ
BROOK	Bit Rate (OOK)	1.56	—	16	kbps	NRZ
FDFSK	Frequency Deviation (FSK)	33	50	200	kHz	—
FXTAL	Crystal Oscillator Frequency	9	12.8	—	MHz	—
FSSTP	Frequency Synthesizer Step	—	2	—	kHz	Variable, depending on the frequency
TSOSC	Oscillator Wake-up Time	—	1.5	5	ms	From Sleep mode <sup>(1)</sup>
TSFS	Frequency Synthesizer Wake-up Time; at most, 10 kHz away from the target	—	500	800	μs	From Stand-by mode
TSHOP	Frequency Synthesizer Hop Time; at most, 10 kHz away from the target	—	180	—	μs	200 kHz step
		—	200	—	μs	1 MHz step
		—	250	—	μs	5 MHz step
		—	260	—	μs	7 MHz step
		—	290	—	μs	12 MHz step
		—	320	—	μs	20 MHz step
		—	340	—	μs	27 MHz step

**Note 1:** Guaranteed by design and characterization.

# MRF89XAM8A

**TABLE 4-5: RECEIVER AC CHARACTERISTICS<sup>(1)</sup>**

Symbol	Parameter	Min	Typ	Max	Unit	Condition
RSF	Sensitivity (FSK)	—	-107	—	dBm	869 MHz, BR = 25 kbps, $f_{dev} = 50$ kHz, $f_c = 100$ kHz
		—	-103	—	dBm	869 MHz, BR = 66.7 kbps, $f_{dev} = 100$ kHz, $f_c = 200$ kHz
RSO	Sensitivity (OOK)	—	-113	—	dBm	869 MHz, 2 kbps NRZ $f_c - f_o = 50$ kHz, $f_o = 50$ kHz
		—	-106	—	dBm	869 MHz, 16.7 kbps NRZ $f_c - f_o = 100$ kHz, $f_o = 100$ kHz
CCR	Co-Channel Rejection	—	-12	—	dBc	Modulation as wanted signal
ACR	Adjacent Channel Rejection	—	27	—	dB	Offset = 300 kHz, unwanted tone is not modulated
		—	52	—	dB	Offset = 600 kHz, unwanted tone is not modulated
		—	57	—	dB	Offset = 1.2 MHz, unwanted tone is not modulated
BI	Blocking Immunity	—	-48	—	dBm	Offset = 1 MHz, unmodulated
		—	-37	—	dBm	Offset = 2 MHz, unmodulated, no SAW
		—	-33	—	dBm	Offset = 10 MHz, unmodulated, no SAW
RXBWF	Receiver Bandwidth in FSK Mode <sup>(2)</sup>	50	—	250	kHz	Single side BW, Polyphase Off
RXBWU	Receiver Bandwidth in OOK Mode <sup>(2)</sup>	50	—	400	kHz	Single side BW, Polyphase On
ITP3	Input Third Order Intercept Point	—	-28	—	dBm	Interferers at 1 MHz and 1.950 MHz offset
TSRWF	Receiver Wake-up Time	—	280	500	μs	From FS to Rx ready
TSRWS	Receiver Wake-up Time	—	600	900	μs	From Stand-by to Rx ready
TSRHOP	Receiver Hop Time from Rx Ready to Rx Ready with a Frequency Hop	—	400	—	μs	200 kHz step
		—	400	—	μs	1 MHz step
		—	460	—	μs	5 MHz step
		—	480	—	μs	7 MHz step
		—	520	—	μs	12 MHz step
		—	550	—	μs	20 MHz step
		—	600	—	μs	27 MHz step
RSSIST	RSSI Sampling Time	—	—	$1/f_{dev}$	s	From Rx ready
RSSTDR	RSSI Dynamic Range	—	70	—	dB	Ranging from sensitivity

**Note 1:** Guaranteed by design and characterization.

**2:** This reflects the whole receiver bandwidth, as described by conditions for active and passive filters.

**TABLE 4-6: TRANSMITTER AC CHARACTERISTICS<sup>(1)</sup>**

Symbol	Description	Min	Typ	Max	Unit	Condition
RFOP	RF Output Power, Programmable with 8 Steps of typ. 3 dB	—	+12.5	—	dBm	Maximum power setting
		—	-8.5	—	dBm	Minimum power setting
PN	Phase Noise	—	-112	—	dBc/Hz	Measured with a 600 kHz offset at the transmitter output
TXSP	Transmitted Spurious	—	—	-47	dBc	At any offset between 200 kHz and 600 kHz, unmodulated carrier, $f_{dev} = 50$ kHz
Tx2	Second Harmonic	—	—	-40	dBm	No modulation, see Note <sup>(2)</sup>
Tx3	Third Harmonic					
Tx4	Fourth Harmonic					
Txn	Harmonics above Tx4					
FSKDEV	FSK Deviation	±33	±55	±200	kHz	Programmable
TSTWF	Transmitter Wake-up Time	—	120	500	µs	From FS to Tx ready
TSTWS	Transmitter Wake-up Time	—	600	900	µs	From Stand-by to Tx ready

**Note 1:** Guaranteed by design and characterization.

**Note 2:** Transmitter in-circuit performance with SAW filter and crystal.

# MRF89XAM8A

## 4.1 Timing Specification and Diagram

TABLE 4-7: SPI TIMING SPECIFICATION<sup>(1,2)</sup>

Parameter	Min	Typ	Max	Unit	Condition
SPI Configure Clock Frequency	—	—	6	MHz	—
SPI Data Clock Frequency	—	—	1	MHz	—
Data Hold and Setup Time	2	—	—	μs	—
SDI Setup Time for SPI Configure	250	—	—	ns	—
SDI Setup Time for SPI Data	312	—	—	ns	—
CSCON Low to SCK Rising Edge; SCK Falling Edge to CSCON High	500	—	—	ns	—
CSDATA Low to SCK Rising Edge; SCK Falling Edge to CSDATA High	625	—	—	ns	—
CSCON Rising to Falling Edge	500	—	—	ns	—
CSDATA Rising to Falling Edge	625	—	—	ns	—

**Note 1:** Typical Values:  $T_A = 25^\circ\text{C}$ ,  $V_{IN} = 3.3\text{V}$ , Crystal Frequency = 12.8 MHz, unless otherwise specified.

**2:** Negative current is defined as the current sourced by the pin.

## APPENDIX A: REVISION HISTORY

### Revision A (November 2010)

This is the Initial release of the document.

# MRF89XAM8A

---

NOTES:

## THE MICROCHIP WEB SITE

Microchip provides online support via our WWW site at [www.microchip.com](http://www.microchip.com). This web site is used as a means to make files and information easily available to customers. Accessible by using your favorite Internet browser, the web site contains the following information:

- **Product Support** – Data sheets and errata, application notes and sample programs, design resources, user's guides and hardware support documents, latest software releases and archived software
- **General Technical Support** – Frequently Asked Questions (FAQ), technical support requests, online discussion groups, Microchip consultant program member listing
- **Business of Microchip** – Product selector and ordering guides, latest Microchip press releases, listing of seminars and events, listings of Microchip sales offices, distributors and factory representatives

## CUSTOMER CHANGE NOTIFICATION SERVICE

Microchip's customer notification service helps keep customers current on Microchip products. Subscribers will receive e-mail notification whenever there are changes, updates, revisions or errata related to a specified product family or development tool of interest.

To register, access the Microchip web site at [www.microchip.com](http://www.microchip.com), click on Customer Change Notification and follow the registration instructions.

## CUSTOMER SUPPORT

Users of Microchip products can receive assistance through several channels:

- Distributor or Representative
- Local Sales Office
- Field Application Engineer (FAE)
- Technical Support
- Development Systems Information Line

Customers should contact their distributor, representative or field application engineer (FAE) for support. Local sales offices are also available to help customers. A listing of sales offices and locations is included in the back of this document.

**Technical support is available through the web site at: <http://support.microchip.com>**

# MRF89XAM8A

---

---

## READER RESPONSE

It is our intention to provide you with the best documentation possible to ensure successful use of your Microchip product. If you wish to provide your comments on organization, clarity, subject matter, and ways in which our documentation can better serve you, please FAX your comments to the Technical Publications Manager at (480) 792-4150.

Please list the following information, and use this outline to provide us with your comments about this document.

TO: Technical Publications Manager Total Pages Sent \_\_\_\_\_

RE: Reader Response

From: Name \_\_\_\_\_

Company \_\_\_\_\_

Address \_\_\_\_\_

City / State / ZIP / Country \_\_\_\_\_

Telephone: (\_\_\_\_\_) \_\_\_\_\_ - \_\_\_\_\_ FAX: (\_\_\_\_\_) \_\_\_\_\_ - \_\_\_\_\_

Application (optional):

Would you like a reply?  Y  N

Device: MRF89XAM8A

Literature Number: DS70651A

Questions:

1. What are the best features of this document?

\_\_\_\_\_  
\_\_\_\_\_

2. How does this document meet your hardware and software development needs?

\_\_\_\_\_  
\_\_\_\_\_

3. Do you find the organization of this document easy to follow? If not, why?

\_\_\_\_\_  
\_\_\_\_\_

4. What additions to the document do you think would enhance the structure and subject?

\_\_\_\_\_  
\_\_\_\_\_

5. What deletions from the document could be made without affecting the overall usefulness?

\_\_\_\_\_  
\_\_\_\_\_

6. Is there any incorrect or misleading information (what and where)?

\_\_\_\_\_  
\_\_\_\_\_

7. How would you improve this document?

\_\_\_\_\_  
\_\_\_\_\_



## PRODUCT IDENTIFICATION SYSTEM

To order or obtain information, for example, on pricing or delivery, refer to the factory or the listed sales office.

<table style="margin: auto; border: none;"> <tr> <td style="text-align: center; padding: 5px;"><u>PART NO.</u></td> <td style="text-align: center; padding: 5px;"><u>M</u></td> <td style="text-align: center; padding: 5px;"><u>X</u></td> <td style="text-align: center; padding: 5px;"><u>I</u></td> <td style="text-align: center; padding: 5px;"><u>-X</u></td> </tr> <tr> <td style="text-align: center; padding: 5px;"> </td> <td style="text-align: center; padding: 5px;"> </td> <td style="text-align: center; padding: 5px;"> </td> <td style="text-align: center; padding: 5px;"> </td> <td style="text-align: center; padding: 5px;"> </td> </tr> <tr> <td style="text-align: center; padding: 5px;">Device</td> <td style="text-align: center; padding: 5px;">Module</td> <td style="text-align: center; padding: 5px;">Module Type</td> <td style="text-align: center; padding: 5px;">Tape and Reel</td> <td style="text-align: center; padding: 5px;">Temperature Range</td> </tr> </table> <table style="width: 100%; border: none;"> <tr> <td style="width: 15%; padding: 5px;">Device</td> <td style="padding: 5px;">MRF89XAM8A-I/RM: Ultra Low-Power, Integrated ISM Band Sub-GHz Transceiver module</td> </tr> <tr> <td style="padding: 5px;">Temperature Range</td> <td style="padding: 5px;">I = -40°C to +85°C (Industrial)</td> </tr> </table>	<u>PART NO.</u>	<u>M</u>	<u>X</u>	<u>I</u>	<u>-X</u>						Device	Module	Module Type	Tape and Reel	Temperature Range	Device	MRF89XAM8A-I/RM: Ultra Low-Power, Integrated ISM Band Sub-GHz Transceiver module	Temperature Range	I = -40°C to +85°C (Industrial)	<p><b>Example:</b></p> <ul style="list-style-type: none"> <li>a) MRF89XAM8A-I/RM: Industrial temperature tray.</li> <li>b) MRF89XAM8AT-I/RM: Industrial temperature tape and reel,</li> </ul>
<u>PART NO.</u>	<u>M</u>	<u>X</u>	<u>I</u>	<u>-X</u>																
Device	Module	Module Type	Tape and Reel	Temperature Range																
Device	MRF89XAM8A-I/RM: Ultra Low-Power, Integrated ISM Band Sub-GHz Transceiver module																			
Temperature Range	I = -40°C to +85°C (Industrial)																			



# MICROCHIP

## Worldwide Sales and Service

### AMERICAS

**Corporate Office**  
2355 West Chandler Blvd.  
Chandler, AZ 85224-6199  
Tel: 480-792-7200  
Fax: 480-792-7277  
Technical Support:  
<http://support.microchip.com>  
Web Address:  
[www.microchip.com](http://www.microchip.com)

**Atlanta**  
Duluth, GA  
Tel: 678-957-9614  
Fax: 678-957-1455

**Boston**  
Westborough, MA  
Tel: 774-760-0087  
Fax: 774-760-0088

**Chicago**  
Itasca, IL  
Tel: 630-285-0071  
Fax: 630-285-0075

**Cleveland**  
Independence, OH  
Tel: 216-447-0464  
Fax: 216-447-0643

**Dallas**  
Addison, TX  
Tel: 972-818-7423  
Fax: 972-818-2924

**Detroit**  
Farmington Hills, MI  
Tel: 248-538-2250  
Fax: 248-538-2260

**Kokomo**  
Kokomo, IN  
Tel: 765-864-8360  
Fax: 765-864-8387

**Los Angeles**  
Mission Viejo, CA  
Tel: 949-462-9523  
Fax: 949-462-9608

**Santa Clara**  
Santa Clara, CA  
Tel: 408-961-6444  
Fax: 408-961-6445

**Toronto**  
Mississauga, Ontario,  
Canada  
Tel: 905-673-0699  
Fax: 905-673-6509

### ASIA/PACIFIC

**Asia Pacific Office**  
Suites 3707-14, 37th Floor  
Tower 6, The Gateway  
Harbour City, Kowloon  
Hong Kong  
Tel: 852-2401-1200  
Fax: 852-2401-3431

**Australia - Sydney**  
Tel: 61-2-9868-6733  
Fax: 61-2-9868-6755

**China - Beijing**  
Tel: 86-10-8528-2100  
Fax: 86-10-8528-2104

**China - Chengdu**  
Tel: 86-28-8665-5511  
Fax: 86-28-8665-7889

**China - Chongqing**  
Tel: 86-23-8980-9588  
Fax: 86-23-8980-9500

**China - Hong Kong SAR**  
Tel: 852-2401-1200  
Fax: 852-2401-3431

**China - Nanjing**  
Tel: 86-25-8473-2460  
Fax: 86-25-8473-2470

**China - Qingdao**  
Tel: 86-532-8502-7355  
Fax: 86-532-8502-7205

**China - Shanghai**  
Tel: 86-21-5407-5533  
Fax: 86-21-5407-5066

**China - Shenyang**  
Tel: 86-24-2334-2829  
Fax: 86-24-2334-2393

**China - Shenzhen**  
Tel: 86-755-8203-2660  
Fax: 86-755-8203-1760

**China - Wuhan**  
Tel: 86-27-5980-5300  
Fax: 86-27-5980-5118

**China - Xian**  
Tel: 86-29-8833-7252  
Fax: 86-29-8833-7256

**China - Xiamen**  
Tel: 86-592-2388138  
Fax: 86-592-2388130

**China - Zhuhai**  
Tel: 86-756-3210040  
Fax: 86-756-3210049

### ASIA/PACIFIC

**India - Bangalore**  
Tel: 91-80-3090-4444  
Fax: 91-80-3090-4123

**India - New Delhi**  
Tel: 91-11-4160-8631  
Fax: 91-11-4160-8632

**India - Pune**  
Tel: 91-20-2566-1512  
Fax: 91-20-2566-1513

**Japan - Yokohama**  
Tel: 81-45-471- 6166  
Fax: 81-45-471-6122

**Korea - Daegu**  
Tel: 82-53-744-4301  
Fax: 82-53-744-4302

**Korea - Seoul**  
Tel: 82-2-554-7200  
Fax: 82-2-558-5932 or  
82-2-558-5934

**Malaysia - Kuala Lumpur**  
Tel: 60-3-6201-9857  
Fax: 60-3-6201-9859

**Malaysia - Penang**  
Tel: 60-4-227-8870  
Fax: 60-4-227-4068

**Philippines - Manila**  
Tel: 63-2-634-9065  
Fax: 63-2-634-9069

**Singapore**  
Tel: 65-6334-8870  
Fax: 65-6334-8850

**Taiwan - Hsin Chu**  
Tel: 886-3-6578-300  
Fax: 886-3-6578-370

**Taiwan - Kaohsiung**  
Tel: 886-7-213-7830  
Fax: 886-7-330-9305

**Taiwan - Taipei**  
Tel: 886-2-2500-6610  
Fax: 886-2-2508-0102

**Thailand - Bangkok**  
Tel: 66-2-694-1351  
Fax: 66-2-694-1350

### EUROPE

**Austria - Wels**  
Tel: 43-7242-2244-39  
Fax: 43-7242-2244-393

**Denmark - Copenhagen**  
Tel: 45-4450-2828  
Fax: 45-4485-2829

**France - Paris**  
Tel: 33-1-69-53-63-20  
Fax: 33-1-69-30-90-79

**Germany - Munich**  
Tel: 49-89-627-144-0  
Fax: 49-89-627-144-44

**Italy - Milan**  
Tel: 39-0331-742611  
Fax: 39-0331-466781

**Netherlands - Drunen**  
Tel: 31-416-690399  
Fax: 31-416-690340

**Spain - Madrid**  
Tel: 34-91-708-08-90  
Fax: 34-91-708-08-91

**UK - Wokingham**  
Tel: 44-118-921-5869  
Fax: 44-118-921-5820

08/04/10