

# Customer Information Sheet

DRAWING No.: M90-3102R10SL-3P

SHEET 2 OF 2

IF IN DOUBT - ASK

©

THIRD ANGLE PROJECTION

NOT TO SCALE

ALL DIMENSIONS IN mm

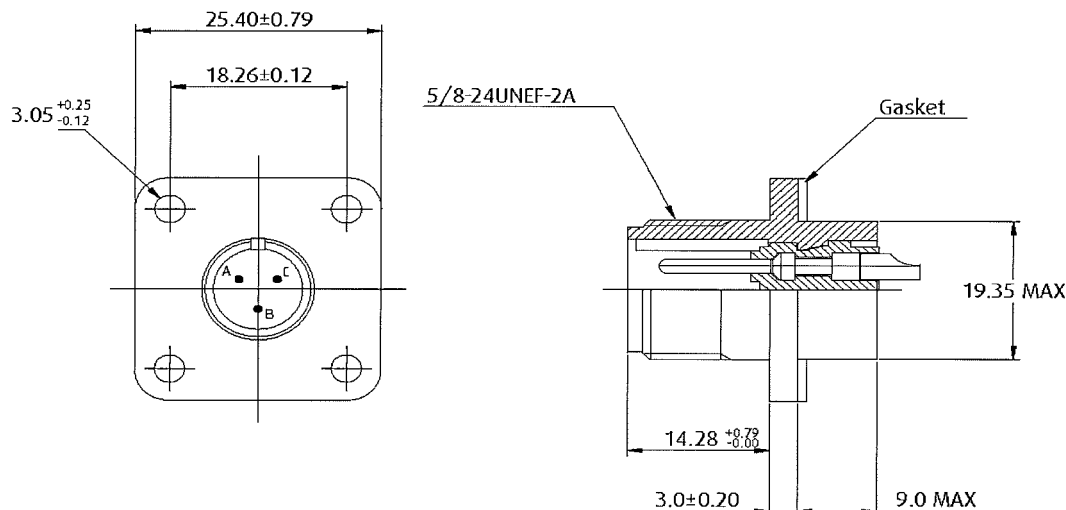

**SPECIFICATIONS:**

**MATERIAL:**

SHELL = ALUMINIUM ALLOY

INSULATOR = POLYCHLOROPRENE

GROMMET = POLYCHLOROPRENE

CONTACT = COPPER ALLOY

**FINISH:**

SHELL = ZINC WITH BLACK CHROMATE COATING

CONTACT = SILVER

**ELECTRICAL:**

CURRENT RATING = 13 AMPS

VOLTAGE RATING = 500V AC, 700V DC

INSULATION RESISTANCE = 5,000 MΩ MIN

**ENVIRONMENTAL:**

TEMPERATURE RANGE = -55°C TO +125°C

VIBRATION = 10 - 500Hz (10G) PER MIL-STD-1344, Method 2005

SALT SPRAY = 48 HRS, 5% SALT SOLUTION, PER MIL-STD-1344 Method 1001

HUMIDITY = 95±3%, 71±2°C, 14 DAYS

**MECHANICAL:**

COUPLING : THREADED

POLARISATION : SINGLE KEY/ KEYWAY

CONTACT TYPE : SOLDER

CONTACT ARRANGEMENT : 3 CONTACTS

DURABILITY : 500 OPERATIONS

**NOTES:**

1. PRODUCT IS RoHS COMPLIANT
2. PRODUCT IS PACKED IN BAGS.
3. RECOMMENDED WIRE SIZE 16-22 AWG.

RA	3	15.01.09	10228
NAME	ISS.	DATE	C/NOTE
APPROVED <i>[Signature]</i>			
CHECKED: <i>[Signature]</i>			
DRAWN: M. G. PLESTED			
CUSTOMER REF:			
ASSEMBLY DRG:			

# HARWIN

THIS INFORMATION AND ANY INFORMATION OR DESCRIPTIVE MATTER SET OUT HEREON ARE CONFIDENTIAL AND COPYRIGHT PROPERTY OF THE HARWIN GROUP AND MUST NOT BE DISCLOSED, LOANED, COPIED OR USED FOR MANUFACTURING, TENDERING OR FOR ANY OTHER PURPOSE WITHOUT THEIR WRITTEN PERMISSION

**TOLERANCES**

X. = ±1mm

X.X = ±0.25mm

X.XX = ±0.10mm

X.XXX = ±0.01mm

ANGLES = ±5°

UNLESS STATED

**MATERIAL:**

SEE ABOVE

**FINISH:**

SEE ABOVE

**S/AREA:**

**TITLE:**

PANEL MOUNT -  
3 PIN CONTACTS

**DRAWING NUMBER:**

**M90-3102R10SL-3P**

SHT

2

OF

2

HARWIN USA

TEL: 603 893 5376

FAX: 603 893 5396

mis@harwin.com

HARWIN Europe (UK)

TEL: 023 9231 4545

FAX: 023 9231 4590

mis@harwin.co.uk

HARWIN Asia

TEL: +65 6 779 4909

FAX: +65 6 779 3868

mis@harwin.com.sg

# Customer Information Sheet

DRAWING No.: M90-3102R10SL-4P

SHEET 2 OF 2

IF IN DOUBT - ASK

©

THIRD ANGLE PROJECTION

NOT TO SCALE

ALL DIMENSIONS IN mm

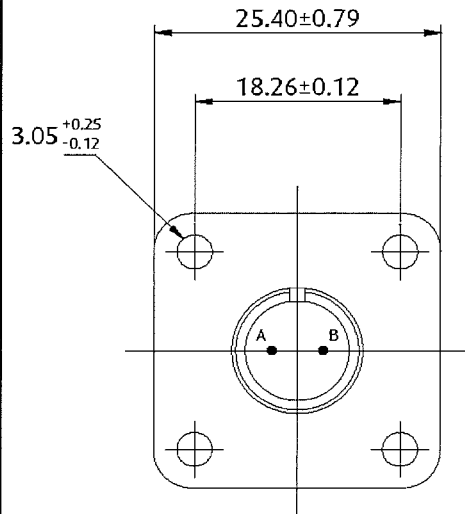

Front of pin insert

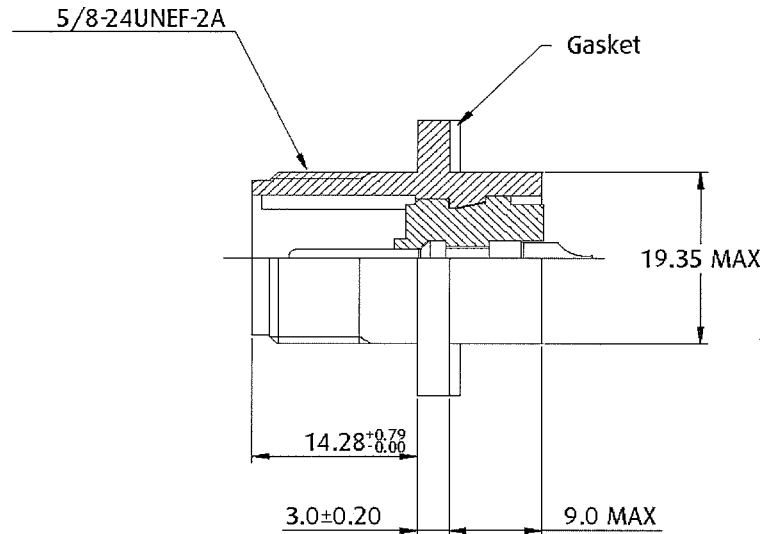

**SPECIFICATIONS:**

**MATERIAL:**

SHELL = ALUMINIUM ALLOY

INSULATOR = POLYCHLOROPRENE

GROMMET = POLYCHLOROPRENE

CONTACT = COPPER ALLOY

**FINISH:**

SHELL = ZINC WITH BLACK CHROMATE COATING

CONTACT = SILVER

**ELECTRICAL:**

CURRENT RATING = 13 AMPS

VOLTAGE RATING = 500V AC, 700V DC

INSULATION RESISTANCE = 5,000 MΩ MIN

**ENVIRONMENTAL:**

TEMPERATURE RANGE = -55°C TO +125°C

VIBRATION = 10 - 500Hz (10G) PER MIL-STD-1344, Method 2005

SALT SPRAY = 48 HRS, 5% SALT SOLUTION, PER MIL-STD-1344 Method 1001

HUMIDITY = 95±3%, 71±2°C, 14 DAYS

**MECHANICAL:**

COUPLING : THREADED

POLARISATION : SINGLE KEY/ KEYWAY

CONTACT TYPE : SOLDER

CONTACT ARRANGEMENT : 2 CONTACTS

DURABILITY : 500 OPERATIONS

**NOTES:**

1. PRODUCT IS RoHS COMPLIANT
2. PRODUCT IS PACKED IN BAGS
3. RECOMMENDED WIRE SIZE 16-22 AWG.

RA	3	15.01.09	10228
NAME	ISS.	DATE	C/NOTE
APPROVED <i>[Signature]</i>			
CHECKED: <i>[Signature]</i>			
DRAWN:		M.G.PLESTED	
CUSTOMER REF:			
ASSEMBLY DRG:			

## HARWIN

HARWIN USA  
TEL: 603 893 5376  
FAX: 603 893 5396  
mis@harwin.com

HARWIN Europe (UK)  
TEL: 023 9231 4545  
FAX: 023 9231 4590  
mis@harwin.co.uk

HARWIN Asia  
TEL: +65 6 779 4909  
FAX: +65 6 779 3868  
mis@harwin.com.sg

THIS INFORMATION AND ANY INFORMATION OR DESCRIPTIVE MATTER SET OUT HEREON ARE CONFIDENTIAL AND COPYRIGHT PROPERTY OF THE HARWIN GROUP AND MUST NOT BE DISCLOSED, LOANED, COPIED OR USED FOR MANUFACTURING, TENDERING OR FOR ANY OTHER PURPOSE WITHOUT THEIR WRITTEN PERMISSION.

**TOLERANCES**  
X. = ±1mm  
X.X = ±0.25mm  
X.XX = ±0.10mm  
X.XXX = ±0.01mm  
**ANGLES = ±5°**  
**UNLESS STATED**

**MATERIAL:**  
SEE ABOVE  
**FINISH:**  
SEE ABOVE  
**S/AREA:**

**TITLE:**  
PANEL MOUNT -  
2 PIN CONTACTS

**DRAWING NUMBER:**  
M90-3102R10SL-4P

SHT  
2  
OF  
2

# Customer Information Sheet

DRAWING No.: M90-3102R12S-3P

SHEET 2 OF 2

IF IN DOUBT - ASK

(C)

NOT TO SCALE

THIRD ANGLE PROJECTION

ALL DIMENSIONS IN mm

**SPECIFICATIONS:**

**MATERIAL:**

SHELL: ALUMINIUM ALLOY  
 INSULATOR: NITRILE BUTADIENE RUBBER  
 GROMMET: NITRILE BUTADIENE RUBBER  
 CONTACT COPPER ALLOY

**FINISH:**

SHELL: ZINC PLATED WITH BLACK CHROMATE COATING  
 CONTACT: SILVER

**ELECTRICAL:**

CURRENT RATING: 13 AMPS  
 VOLTAGE RATING: 500V AC, 700V DC  
 INSULATION RESISTANCE: 5,000 MΩ MIN

**MECHANICAL:**

COUPLING: THREADED  
 POLARISATION: SINGLE KEY/KEYWAY  
 CONTACT TYPE: SOLDER  
 CONTACT ARRANGEMENT: 2 CONTACTS  
 DURABILITY: 500 CYCLES

**ENVIRONMENTAL:**

TEMPERATURE RANGE: -55°C TO -125°C  
 VIBRATION: 10-500Hz(10G), PER MIL-STD-1344, METHOD 2005  
 SALT SPRAY: 48HRS. SALT SOLUTION 5%, PER MIL-1344, METHOD 1001  
 HUMIDITY: RELATIVE HUMIDITY 95±3%, 71°C±2°C, 14 DAYS

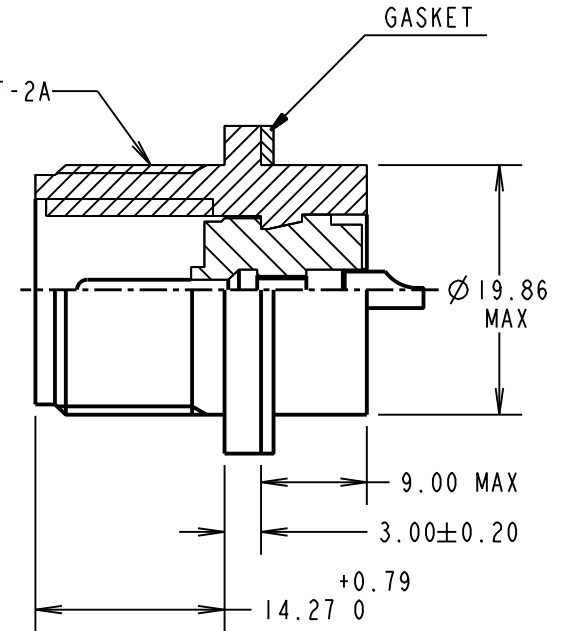
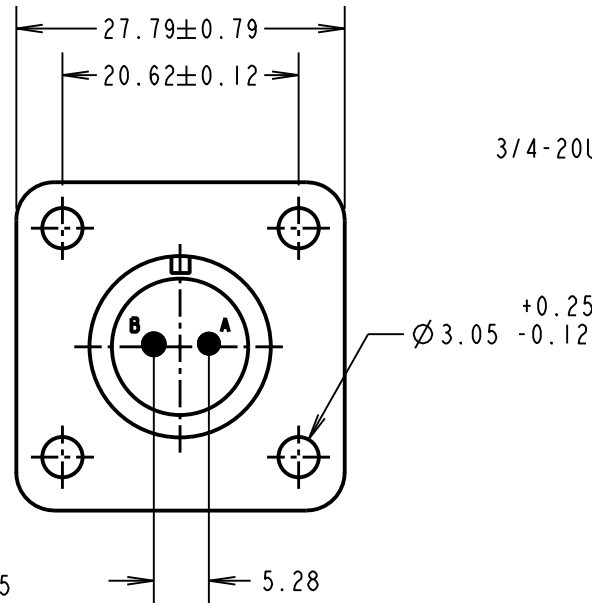

RA	3	12.08.10	10900
NAME	ISS.	DATE	C/NOTE
APPROVED:		R. ADDE	
CHECKED:		M.G. PLESTED	
DRAWN:		R. ADDE	
CUSTOMER REF.:			
ASSEMBLY DRG:			

**NOTES:**

1. PRODUCT IS RoHS COMPLIANT
2. PRODUCT IS PACKED IN BAGS.
3. RECOMMENDED WIRE SIZE 16-22 AWG.

**HARWIN**

HARWIN USA TEL: 603 893 5376 FAX: 603 893 5396 mis@harwin.com	HARWIN Europe (UK) TEL: 023 9231 4545 FAX: 023 9231 4590 mis@harwin.co.uk	HARWIN Asia TEL: +65 6 779 4909 FAX: +65 6 779 3868 mis@harwin.com.sg
--	--	--

THIS DRAWING AND ANY INFORMATION OR DESCRIPTIVE MATTER SET OUT HEREON ARE CONFIDENTIAL AND COPYRIGHT PROPERTY OF THE HARWIN GROUP AND MUST NOT BE DISCLOSED, LOANED, COPIED OR USED FOR MANUFACTURING, TENDERING OR FOR ANY OTHER PURPOSE WITHOUT THEIR WRITTEN PERMISSION.

**TOLERANCES**  
 X. = ±1mm  
 X.X = ±0.25mm  
 X.XX = ±0.10mm  
 X.XXX = ±0.01mm  
 ANGLES = ±5°  
 UNLESS STATED

**MATERIAL:**  
 SEE ABOVE  
**FINISH:**  
**S/AREA:** mm<sup>2</sup>

**TITLE:**  
 CABLE CONNECTOR-  
 2 PIN CONTACTS  
**DRAWING NUMBER:**  
 M90-3102R12S-3P  
 SHT 2 OF 2

# Customer Information Sheet

DRAWING No.: M90-3102R14S-2P

SHEET 2 OF 2

IF IN DOUBT - ASK

©

THIRD ANGLE PROJECTION

NOT TO SCALE

ALL DIMENSIONS IN mm

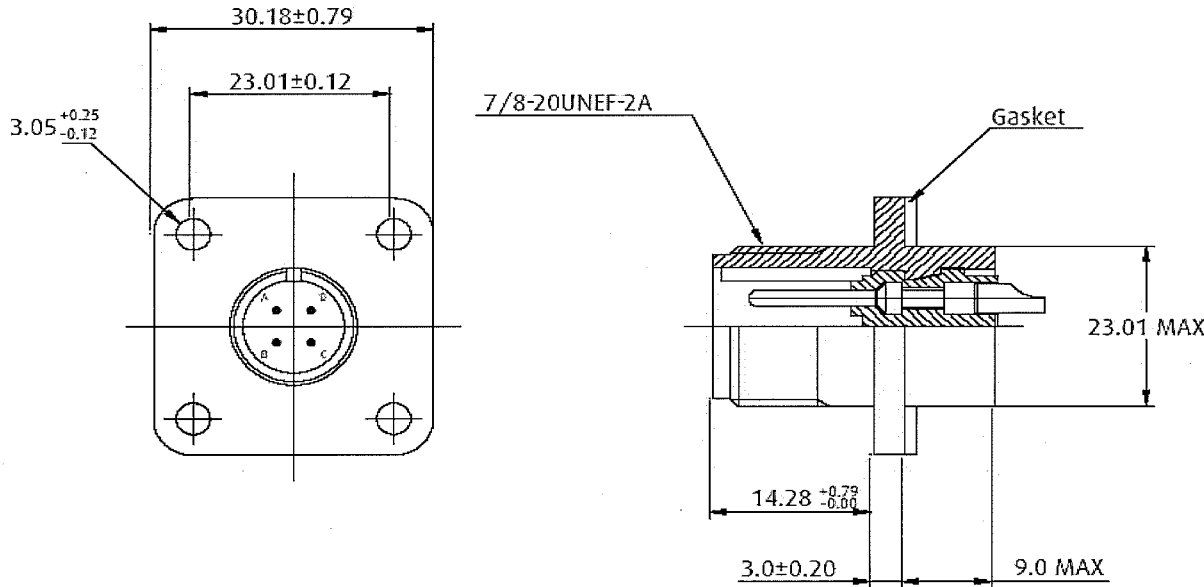

**NOTES:**

1. PRODUCT IS RoHS COMPLIANT
2. PRODUCT IS PACKED IN BAGS
3. RECOMMENDED WIRE SIZE 16-22 AWG.

**SPECIFICATIONS:**

**MATERIAL:**

SHELL = ALUMINIUM ALLOY  
 INSULATOR = POLYCHLOROPRENE  
 GROMMET = POLYCHLOROPRENE  
 CONTACT = COPPER ALLOY

**FINISH:**

SHELL = ZINC WITH BLACK CHROMATE COATING  
 CONTACT = SILVER

**ELECTRICAL:**

CURRENT RATING = 13 AMPS  
 VOLTAGE RATING = 200V AC, 250V DC  
 INSULATION RESISTANCE = 5,000 MΩ MIN

**ENVIRONMENTAL:**

TEMPERATURE RANGE = -55°C TO +125°C  
 VIBRATION = 10 - 500Hz (10G) PER MIL-STD-1344, Method 2005  
 SALT SPRAY = 48 HRS, 5% SALT SOLUTION, PER MIL-STD-1344  
 Method 1001

HUMIDITY = 95±3%, 71±2°C, 14 DAYS

**MECHANICAL:**

COUPLING : THREADED  
 POLARISATION : SINGLE KEY/ KEYWAY  
 CONTACT TYPE : SOLDER  
 CONTACT ARRANGEMENT : 4 CONTACTS  
 DURABILITY : 500 OPERATIONS

RA	4	15.01.09	10228
NAME	ISS.	DATE	C/NOTE
APPROVED <i>[Signature]</i>			
CHECKED: <i>[Signature]</i>			
DRAWN:		M.G.PLESTED	
CUSTOMER REF:			
ASSEMBLY DRG:			

## HARWIN

THIS INFORMATION AND ANY INFORMATION OR DESCRIPTIVE MATTER SET OUT HEREON ARE CONFIDENTIAL AND COPYRIGHT PROPERTY OF THE HARWIN GROUP AND MUST NOT BE DISCLOSED, LOANED, COPIED OR USED FOR MANUFACTURING, TENDERING OR FOR ANY OTHER PURPOSE WITHOUT THEIR WRITTEN PERMISSION.

**TOLERANCES**

X. = ±1mm  
 X.X = ±0.25mm  
 X.XX = ±0.10mm  
 X.XXX = ±0.01mm  
 ANGLES = ±5°  
 UNLESS STATED

**MATERIAL:**

SEE ABOVE

**FINISH:**

SEE ABOVE

**S/AREA:**

**TITLE:**

PANEL MOUNT -  
4 PIN CONTACTS

**DRAWING NUMBER:**

**M90-3102R14S-2P**

**SHT**

2

**OF**

2

**HARWIN USA**

TEL: 603 893 5376  
 FAX: 603 893 5396  
 mis@harwin.com

**HARWIN Europe (UK)**

TEL: 023 9231 4545  
 FAX: 023 9231 4590  
 mis@harwin.co.uk

**HARWIN Asia**

TEL: +65 6 779 4909  
 FAX: +65 6 779 3868  
 mis@harwin.com.sg

# Customer Information Sheet

DRAWING No.: M90-3102R14S-6P

SHEET 2 OF 2

IF IN DOUBT - ASK

©

THIRD ANGLE PROJECTION

NOT TO SCALE

ALL DIMENSIONS IN mm

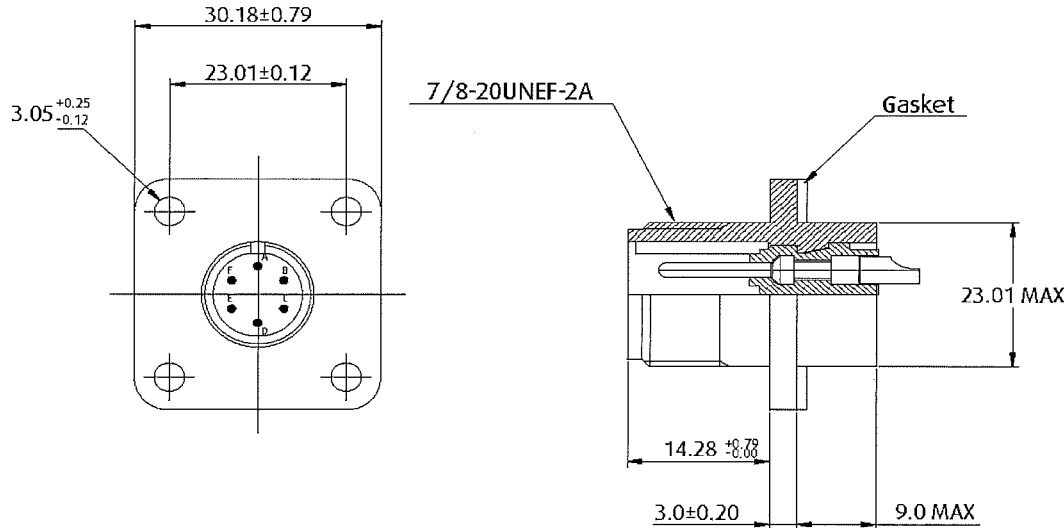

**SPECIFICATIONS:**

**MATERIAL:**

SHELL = ALUMINIUM ALLOY

INSULATOR = POLYCHLOROPRENE

GROMMET = POLYCHLOROPRENE

CONTACT = COPPER ALLOY

**FINISH:**

SHELL = ZINC WITH BLACK CHROMATE COATING

CONTACT = SILVER

**ELECTRICAL:**

CURRENT RATING = 13 AMPS

VOLTAGE RATING = 200V AC, 250V DC

INSULATION RESISTANCE = 5,000 MΩ MIN

**ENVIRONMENTAL:**

TEMPERATURE RANGE = -55°C TO +125°C

VIBRATION = 10 - 500Hz (10G) PER MIL-STD-1344, Method 2005

SALT SPRAY = 48 HRS, 5% SALT SOLUTION, PER MIL-STD-1344 Method 1001

HUMIDITY = 95±3%, 71±2°C, 14 DAYS

**MECHANICAL:**

COUPLING : THREADED

POLARISATION : SINGLE KEY/ KEYWAY

CONTACT TYPE : SOLDER

CONTACT ARRANGEMENT : 6 CONTACTS

DURABILITY : 500 OPERATIONS

**NOTES:**

1. PRODUCT IS RoHS COMPLIANT
2. PRODUCT IS PACKED IN BAGS
3. RECOMMENDED WIRE SIZE 16-22 AWG.

RA	4	15.01.09	10228
NAME	ISS.	DATE	C/NOTE
APPROVED <i>[Signature]</i>			
CHECKED: <i>[Signature]</i>			
DRAWN: M.G.PLESTED			
CUSTOMER REF:			
ASSEMBLY DRG:			

## HARWIN

THIS INFORMATION AND ANY INFORMATION OR DESCRIPTIVE MATTER SET OUT HEREON ARE CONFIDENTIAL AND COPYRIGHT PROPERTY OF THE HARWIN GROUP AND MUST NOT BE DISCLOSED, LOANED, COPIED OR USED FOR MANUFACTURING, TENDERING OR FOR ANY OTHER PURPOSE WITHOUT THEIR WRITTEN PERMISSION.

**TOLERANCES**

X. = ±1mm

X.X = ±0.25mm

X.XX = ±0.10mm

X.XXX = ±0.01mm

ANGLES = ±5°

UNLESS STATED

**MATERIAL:**

SEE ABOVE

**FINISH:**

SEE ABOVE

**S/AREA:**

**TITLE:**

PANEL MOUNT -  
6 PIN CONTACTS

**DRAWING NUMBER:**

**M90-3102R14S-6P**

**SHT**

2

OF

2

HARWIN USA

TEL: 603 893 5376

FAX: 603 893 5396

mis@harwin.com

HARWIN Europe (UK)

TEL: 023 9231 4545

FAX: 023 9231 4590

mis@harwin.co.uk

HARWIN Asia

TEL: +65 6 779 4909

FAX: +65 6 779 3868

mis@harwin.com.sg