

## 1.8V Low-Power Open-Drain Output Comparator

### Features:

- Propagation Delay at 1.8V<sub>DD</sub>:
  - 56 ns (typical) High-to-Low
- Low Quiescent Current: 100  $\mu$ A (typical)
- Input Offset Voltage:  $\pm 3$  mV (typical)
- Rail-to-Rail Input: V<sub>SS</sub> - 0.3V to V<sub>DD</sub> + 0.3V
- Open-Drain Output
- Wide Supply Voltage Range: 1.8V to 5.5V
- Available in Single, Dual and Quad
- Packages: SC70, SOT-23-5, SOIC, MSOP, TSSOP

### Typical Applications:

- Laptop Computers
- Mobile Phones
- Hand-held Electronics
- RC Timers
- Alarm and Monitoring Circuits
- Window Comparators
- Multi-vibrators

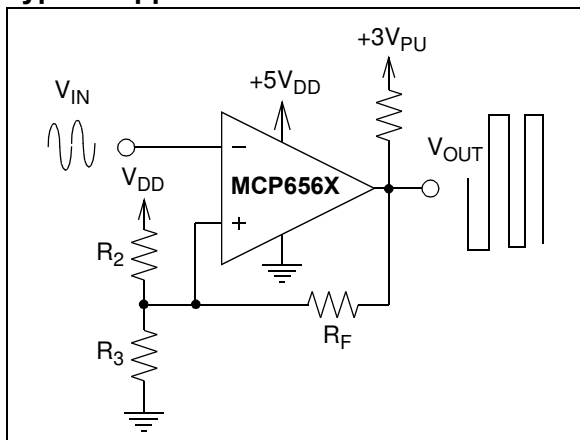
### Design Aids:

- Microchip Advanced Part Selector (MAPS)
- Analog Demonstration and Evaluation Boards
- Application Notes

### Related Device:

- Push-Pull Output: MCP6561/1R/1U/2/4

### Typical Application



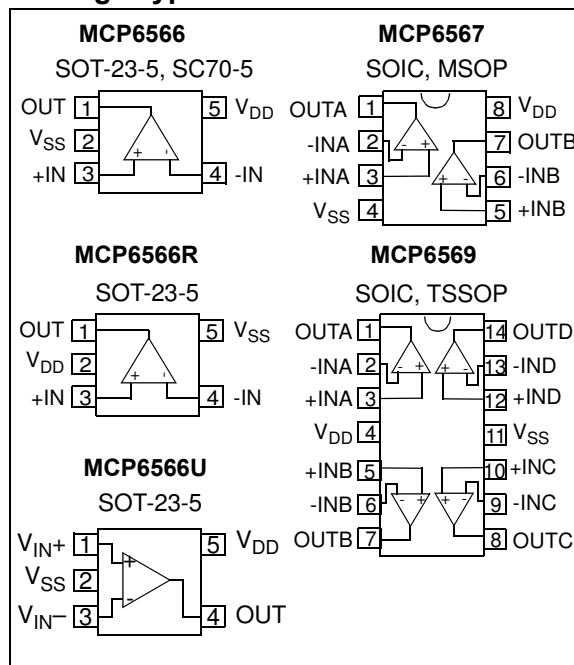
### Description:

The Microchip Technology, Inc. MCP6566/6R/6U/7/9 families of open-drain output comparators are offered in single, dual and quad configurations.

These comparators are optimized for low-power 1.8V, single-supply applications with greater than rail-to-rail input operation. The internal input hysteresis eliminates output switching due to internal input noise voltage, reducing current draw. The open-drain output of the MCP6566/6R/6U/7/9 family requires a pull-up resistor and it supports pull-up voltages above and below V<sub>DD</sub>, which can be used to level shift. The output toggle frequency can reach a typical of 4 MHz (typical) while limiting supply current surges and dynamic power consumption during switching.

This family operates with single supply voltage of 1.8V to 5.5V while drawing less than 100  $\mu$ A/comparator of quiescent current (typical).

### Package Types



# MCP6566/6R/6U/7/9

---

NOTES:

## 1.0 ELECTRICAL CHARACTERISTICS

### 1.1 Maximum Ratings\*

|                                          |                                    |
|------------------------------------------|------------------------------------|
| $V_{DD} - V_{SS}$ .....                  | 6.5V                               |
| Open-Drain Output.....                   | $V_{SS} + 10.5V$                   |
| All other inputs and outputs.....        | $V_{SS} - 0.3V$ to $V_{DD} + 0.3V$ |
| Difference Input voltage .....           | $ V_{DD} - V_{SS} $                |
| Output Short Circuit Current .....       | $\pm 25$ mA                        |
| Current at Input Pins .....              | $\pm 2$ mA                         |
| Current at Output and Supply Pins .....  | $\pm 50$ mA                        |
| Storage temperature .....                | $-65^{\circ}C$ to $+150^{\circ}C$  |
| Ambient temp. with power applied .....   | $-40^{\circ}C$ to $+125^{\circ}C$  |
| Junction temp.....                       | $+150^{\circ}C$                    |
| ESD protection on all pins (HBM/MM)..... | $\geq 4$ kV/300V                   |

**\*Notice:** Stresses above those listed under “Maximum Ratings” may cause permanent damage to the device. This is a stress rating only and functional operation of the device at those or any other conditions above those indicated in the operational listings of this specification is not implied. Exposure to maximum rating conditions for extended periods may affect device reliability.

## DC CHARACTERISTICS

**Electrical Characteristics:** Unless otherwise indicated:  $V_{DD} = +1.8V$  to  $+5.5V$ ,  $V_{SS} = GND$ ,  $T_A = +25^{\circ}C$ ,  $V_{IN+} = V_{DD}/2$ ,  $V_{IN-} = V_{SS}$ , and  $R_{PULL-UP} = 20$  k $\Omega$  to  $V_{PU} = V_{DD}$  (see [Figure 1-1](#)).

| Parameters                           | Symbol                   | Min          | Typ          | Max          | Units               | Conditions                                             |
|--------------------------------------|--------------------------|--------------|--------------|--------------|---------------------|--------------------------------------------------------|
| <b>Power Supply</b>                  |                          |              |              |              |                     |                                                        |
| Supply Voltage                       | $V_{DD}$                 | 1.8          | —            | 5.5          | V                   |                                                        |
| Quiescent Current per comparator     | $I_Q$                    | 60           | 100          | 130          | $\mu A$             | $I_{OUT} = 0$                                          |
| Power Supply Rejection Ratio         | PSRR                     | 63           | 70           | —            | dB                  | $V_{CM} = V_{SS}$                                      |
| <b>Input</b>                         |                          |              |              |              |                     |                                                        |
| Input Offset Voltage                 | $V_{OS}$                 | -10          | $\pm 3$      | +10          | mV                  | $V_{CM} = V_{SS}$ ( <b>Note 1</b> )                    |
| Input Offset Drift                   | $\Delta V_{OS}/\Delta T$ | —            | $\pm 2$      | —            | $\mu V/^{\circ}C$   | $V_{CM} = V_{SS}$                                      |
| Input Offset Current                 | $I_{OS}$                 | —            | $\pm 1$      | —            | pA                  | $V_{CM} = V_{SS}$                                      |
| Input Bias Current                   | $I_B$                    | —            | 1            | —            | pA                  | $T_A = +25^{\circ}C$ , $V_{IN-} = V_{DD}/2$            |
|                                      |                          | —            | 60           | —            | pA                  | $T_A = +85^{\circ}C$ , $V_{IN-} = V_{DD}/2$            |
|                                      |                          | —            | 1500         | 5000         | pA                  | $T_A = +125^{\circ}C$ , $V_{IN-} = V_{DD}/2$           |
| Input Hysteresis Voltage             | $V_{HYST}$               | 1.0          | —            | 5.0          | mV                  | $V_{CM} = V_{SS}$ ( <b>Notes 1, 2</b> )                |
| Input Hysteresis Linear Temp. Co.    | $TC_1$                   | —            | 10           | —            | $\mu V/^{\circ}C$   |                                                        |
| Input Hysteresis Quadratic Temp. Co. | $TC_2$                   | —            | 0.3          | —            | $\mu V/^{\circ}C^2$ |                                                        |
| Common-Mode Input Voltage Range      | $V_{CMR}$                | $V_{SS}-0.2$ | —            | $V_{DD}+0.2$ | V                   | $V_{DD} = 1.8V$                                        |
|                                      |                          | $V_{SS}-0.3$ | —            | $V_{DD}+0.3$ | V                   | $V_{DD} = 5.5V$                                        |
| Common-Mode Rejection Ratio          | CMRR                     | 54           | 66           | —            | dB                  | $V_{CM} = -0.3V$ to $V_{DD}+0.3V$ , $V_{DD} = 5.5V$    |
|                                      |                          | 50           | 63           | —            | dB                  | $V_{CM} = V_{DD}/2$ to $V_{DD}+0.3V$ , $V_{DD} = 5.5V$ |
|                                      |                          | 54           | 65           | —            | dB                  | $V_{CM} = -0.3V$ to $V_{DD}/2$ , $V_{DD} = 5.5V$       |
| Common Mode Input Impedance          | $Z_{CM}$                 | —            | $10^{13}  4$ | —            | $\Omega  pF$        |                                                        |
| Differential Input Impedance         | $Z_{DIFF}$               | —            | $10^{13}  2$ | —            | $\Omega  pF$        |                                                        |

- Note 1:** The input offset voltage is the center of the input-referred trip points. The input hysteresis is the difference between the input-referred trip points.
- 2:**  $V_{HYST}$  at different temperatures is estimated using  $V_{HYST}(T_A) = V_{HYST}@+25^{\circ}C + (T_A - 25^{\circ}C)TC_1 + (T_A - 25^{\circ}C)^2TC_2$ .
- 3:** Limit the output current to Absolute Maximum Rating of 50 mA.
- 4:** The pull-up voltage for the open drain output  $V_{PULL\_UP}$  can be as high as the absolute maximum rating of 10.5V. In this case,  $I_{OH\_leak}$  can be higher than 1  $\mu A$  (see [Figure 2-30](#)).

# MCP6566/6R/6U/7/9

## DC CHARACTERISTICS (CONTINUED)

**Electrical Characteristics:** Unless otherwise indicated:  $V_{DD} = +1.8V$  to  $+5.5V$ ,  $V_{SS} = GND$ ,  $T_A = +25^\circ C$ ,  $V_{IN+} = V_{DD}/2$ ,  $V_{IN-} = V_{SS}$ , and  $R_{PULL-UP} = 20\text{ k}\Omega$  to  $V_{PU} = V_{DD}$  (see [Figure 1-1](#)).

| Parameters                               | Symbol         | Min | Typ      | Max            | Units   | Conditions                                                 |
|------------------------------------------|----------------|-----|----------|----------------|---------|------------------------------------------------------------|
| <b>Push-Pull Output</b>                  |                |     |          |                |         |                                                            |
| Pull-up Voltage                          | $V_{PULL\_UP}$ | 1.6 | —        | 5.5            | V       |                                                            |
| High Level Output Voltage                | $V_{OH}$       | —   | —        | $V_{PULL\_UP}$ | V       | (see <a href="#">Figure 1-1</a> ) ( <b>Notes 3, 4</b> )    |
| High Level Output Current leakage        | $I_{OH\_leak}$ | —   | —        | 1              | $\mu A$ | <b>Note 4</b>                                              |
| Low Level Output Voltage                 | $V_{OL}$       | —   | —        | 0.6            | V       | $I_{OUT} = 3\text{ mA}/8\text{ mA}$ @ $V_{DD} = 1.8V/5.5V$ |
| Short Circuit Current ( <b>Notes 3</b> ) | $I_{SC}$       | —   | $\pm 30$ | —              | mA      | Not to exceed Absolute Max. Rating                         |
| Output Pin Capacitance                   | $C_{OUT}$      | —   | 8        | —              | pF      |                                                            |

- Note 1:** The input offset voltage is the center of the input-referred trip points. The input hysteresis is the difference between the input-referred trip points.
- Note 2:**  $V_{HYST}$  at different temperatures is estimated using  $V_{HYST}(T_A) = V_{HYST}@+25^\circ C + (T_A - 25^\circ C) TC_1 + (T_A - 25^\circ C)^2 TC_2$ .
- Note 3:** Limit the output current to Absolute Maximum Rating of 50 mA.
- Note 4:** The pull-up voltage for the open drain output  $V_{PULL\_UP}$  can be as high as the absolute maximum rating of 10.5V. In this case,  $I_{OH\_leak}$  can be higher than 1  $\mu A$  (see [Figure 2-30](#)).

## AC CHARACTERISTICS

**Electrical Characteristics:** Unless otherwise indicated, : Unless otherwise indicated, :  $V_{DD} = +1.8V$  to  $+5.5V$ ,  $V_{SS} = GND$ ,  $T_A = +25^\circ C$ ,  $V_{IN+} = V_{DD}/2$ ,  $V_{IN-} = V_{SS}$ ,  $R_{PULL-UP} = 20\text{ k}\Omega$  to  $V_{PU} = V_{DD}$ , and  $C_L = 25\text{ pf}$  (see [Figure 1-1](#)).

| Parameters                    | Symbol    | Min | Typ | Max | Units         | Conditions                            |
|-------------------------------|-----------|-----|-----|-----|---------------|---------------------------------------|
| <b>Propagation Delay</b>      |           |     |     |     |               |                                       |
| High-to-Low, 100 mV Overdrive | $t_{PHL}$ | —   | 56  | 80  | ns            | $V_{CM} = V_{DD}/2$ , $V_{DD} = 1.8V$ |
|                               |           | —   | 34  | 80  | ns            | $V_{CM} = V_{DD}/2$ , $V_{DD} = 5.5V$ |
| <b>Output</b>                 |           |     |     |     |               |                                       |
| Fall Time                     | $t_F$     | —   | 20  | —   | ns            |                                       |
| Maximum Toggle Frequency      | $f_{TG}$  | —   | 4   | —   | MHz           | $V_{DD} = 5.5V$                       |
|                               |           | —   | 2   | —   | MHz           | $V_{DD} = 1.8V$                       |
| Input Voltage Noise           | $E_{NI}$  | —   | 350 | —   | $\mu V_{P-P}$ | 10 Hz to 10 MHz ( <b>Note 1</b> )     |

- Note 1:** ENI is based on SPICE simulation.
- Note 2:** Rise time  $t_{r}$  and  $t_{PLH}$  depend on the load ( $R_L$  and  $C_L$ ). These specification are valid for the specified load only.

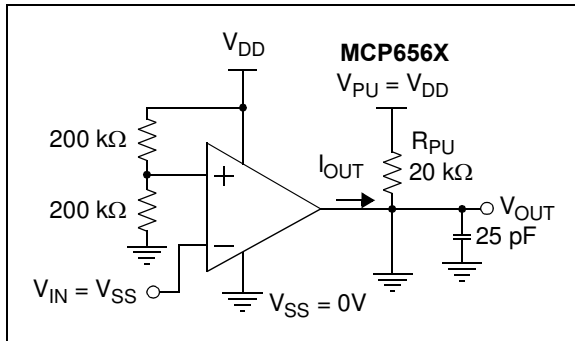
## TEMPERATURE SPECIFICATIONS

**Electrical Characteristics:** Unless otherwise indicated:  $V_{DD} = +1.8V$  to  $+5.5V$  and  $V_{SS} = GND$ .

| Parameters                         | Symbol        | Min | Typ   | Max  | Units        | Conditions |
|------------------------------------|---------------|-----|-------|------|--------------|------------|
| <b>Temperature Ranges</b>          |               |     |       |      |              |            |
| Specified Temperature Range        | $T_A$         | -40 | —     | +125 | $^\circ C$   |            |
| Operating Temperature Range        | $T_A$         | -40 | —     | +125 | $^\circ C$   |            |
| Storage Temperature Range          | $T_A$         | -65 | —     | +150 | $^\circ C$   |            |
| <b>Thermal Package Resistances</b> |               |     |       |      |              |            |
| Thermal Resistance, SC70-5         | $\theta_{JA}$ | —   | 331   | —    | $^\circ C/W$ |            |
| Thermal Resistance, SOT-23-5       | $\theta_{JA}$ | —   | 220.7 | —    | $^\circ C/W$ |            |
| Thermal Resistance, 8L-MSOP        | $\theta_{JA}$ | —   | 211   | —    | $^\circ C/W$ |            |
| Thermal Resistance, 8L-SOIC        | $\theta_{JA}$ | —   | 149.5 | —    | $^\circ C/W$ |            |
| Thermal Resistance, 14L-SOIC       | $\theta_{JA}$ | —   | 95.3  | —    | $^\circ C/W$ |            |
| Thermal Resistance, 14L-TSSOP      | $\theta_{JA}$ | —   | 100   | —    | $^\circ C/W$ |            |

## 1.2 Test Circuit Configuration

This test circuit configuration is used to determine the AC and DC specifications.



**FIGURE 1-1:** AC and DC Test Circuit for the Open-Drain Output Comparators.

# MCP6566/6R/6U/7/9

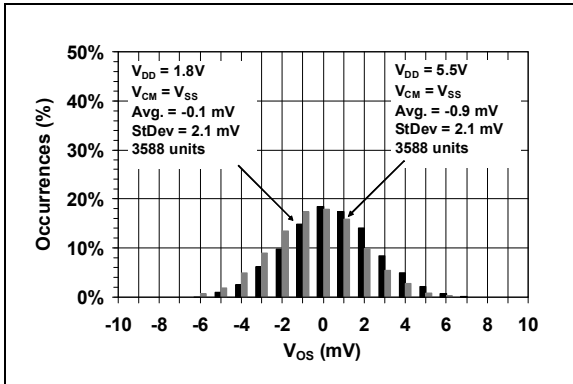
---

NOTES:

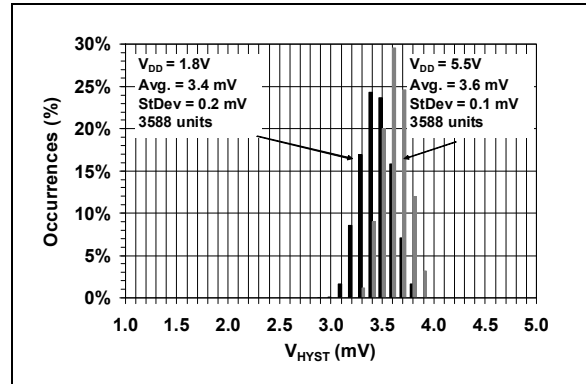
## 2.0 TYPICAL PERFORMANCE CURVES

**Note:** The graphs and tables provided following this note are a statistical summary based on a limited number of samples and are provided for informational purposes only. The performance characteristics listed herein are not tested or guaranteed. In some graphs or tables, the data presented may be outside the specified operating range (e.g., outside specified power supply range) and therefore outside the warranted range.

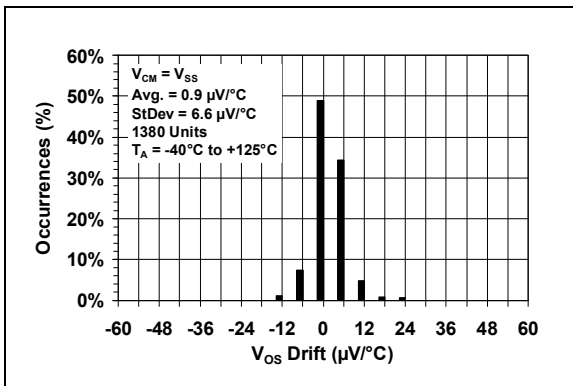
**Note:** Unless otherwise indicated,  $V_{DD} = +1.8V$  to  $+5.5V$ ,  $V_{SS} = GND$ ,  $T_A = +25^\circ C$ ,  $V_{IN+} = V_{DD}/2$ ,  $V_{IN-} = GND$ ,  $R_L = 20\text{ k}\Omega$  to  $V_{PU} = V_{DD}$ , and  $C_L = 25\text{ pF}$ .



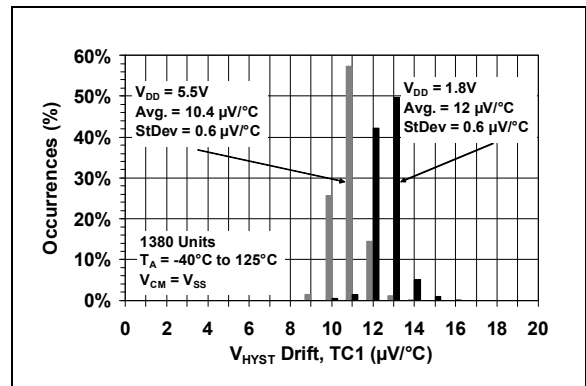
**FIGURE 2-1:** Input Offset Voltage.



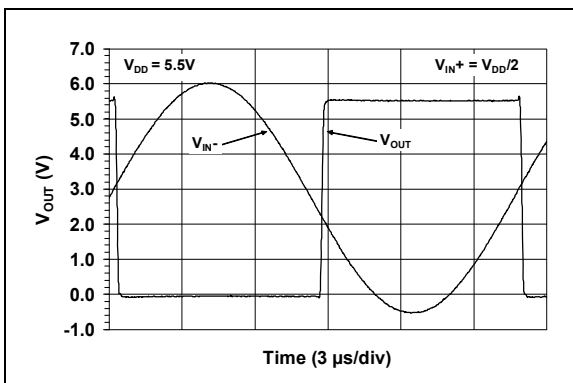
**FIGURE 2-4:** Input Hysteresis Voltage.



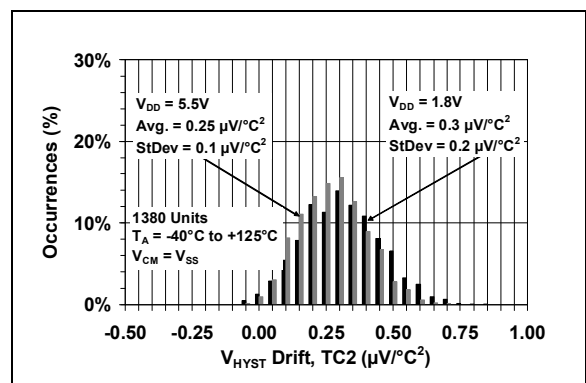
**FIGURE 2-2:** Input Offset Voltage Drift.



**FIGURE 2-5:** Input Hysteresis Voltage Drift - Linear Temp. Co. (TC1).



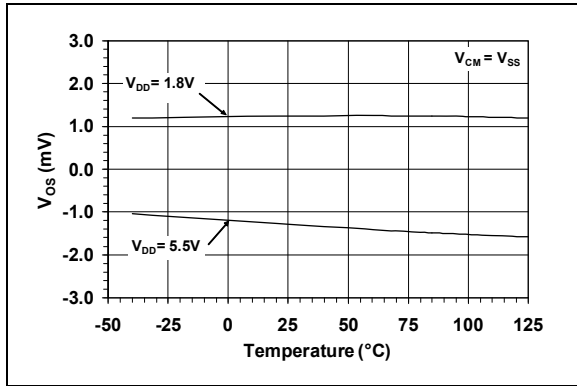
**FIGURE 2-3:** Input vs. Output Signal, No Phase Reversal.



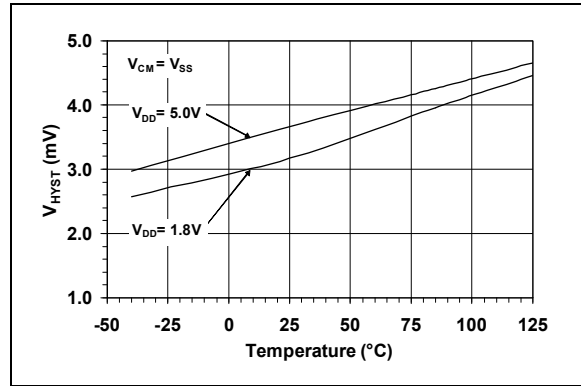
**FIGURE 2-6:** Input Hysteresis Voltage Drift - Quadratic Temp. Co. (TC2).

# MCP6566/6R/6U/7/9

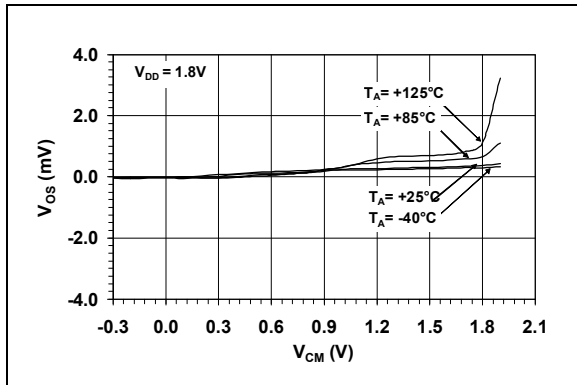
**Note:** Unless otherwise indicated,  $V_{DD} = +1.8V$  to  $+5.5V$ ,  $V_{SS} = GND$ ,  $T_A = +25^\circ C$ ,  $V_{IN+} = V_{DD}/2$ ,  $V_{IN-} = GND$ ,  $R_L = 20\text{ k}\Omega$  to  $V_{PU} = V_{DD}$ , and  $C_L = 25\text{ pF}$ .



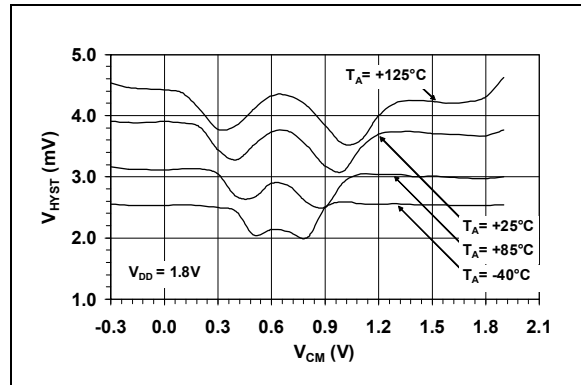
**FIGURE 2-7:** Input Offset Voltage vs. Temperature.



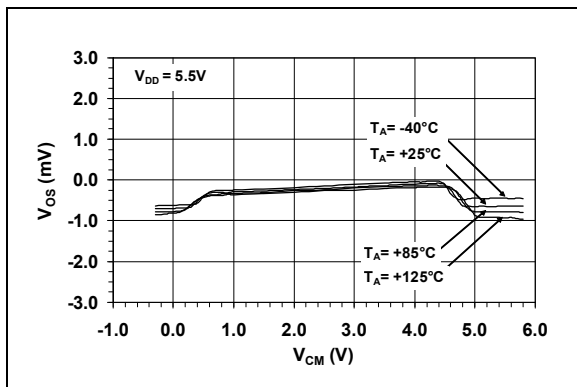
**FIGURE 2-10:** Input Hysteresis Voltage vs. Temperature.



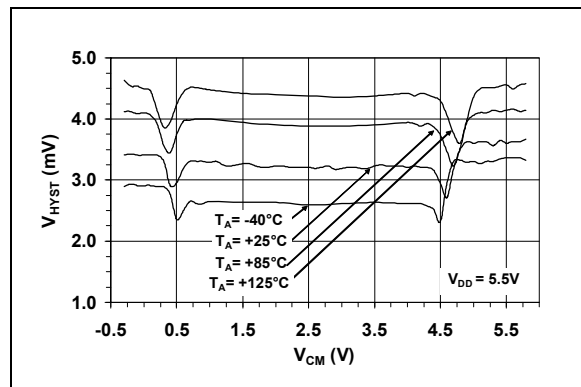
**FIGURE 2-8:** Input Offset Voltage vs. Common-mode Input Voltage.



**FIGURE 2-11:** Input Hysteresis Voltage vs. Common-mode Input Voltage.



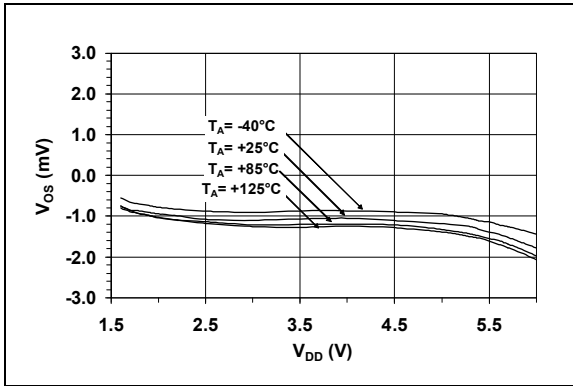
**FIGURE 2-9:** Input Offset Voltage vs. Common-mode Input Voltage.



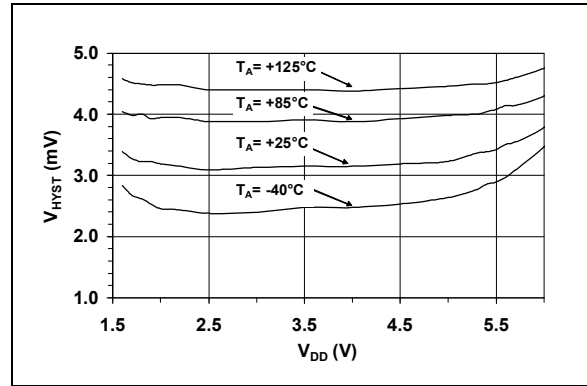
**FIGURE 2-12:** Input Hysteresis Voltage vs. Common-mode Input Voltage.



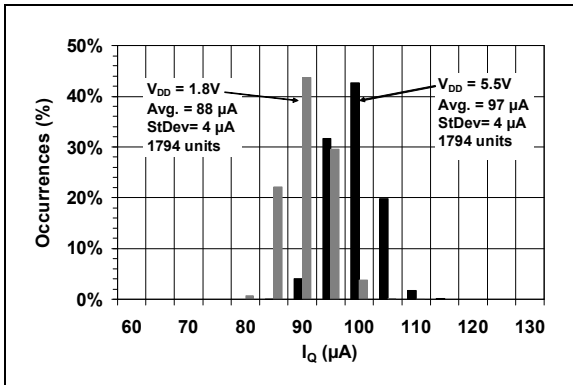
**Note:** Unless otherwise indicated,  $V_{DD} = +1.8V$  to  $+5.5V$ ,  $V_{SS} = GND$ ,  $T_A = +25^\circ C$ ,  $V_{IN+} = V_{DD}/2$ ,  $V_{IN-} = GND$ ,  $R_L = 20\text{ k}\Omega$  to  $V_{PU} = V_{DD}$ , and  $C_L = 25\text{ pF}$ .



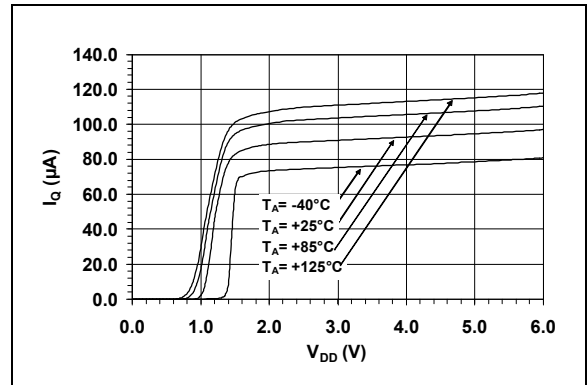
**FIGURE 2-13:** Input Offset Voltage vs. Supply Voltage vs. Temperature.



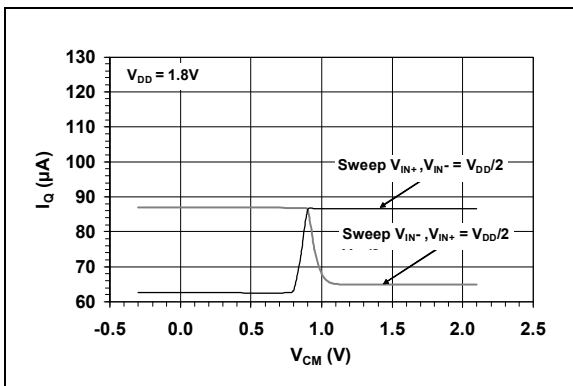
**FIGURE 2-16:** Input Hysteresis Voltage vs. Supply Voltage vs. Temperature.



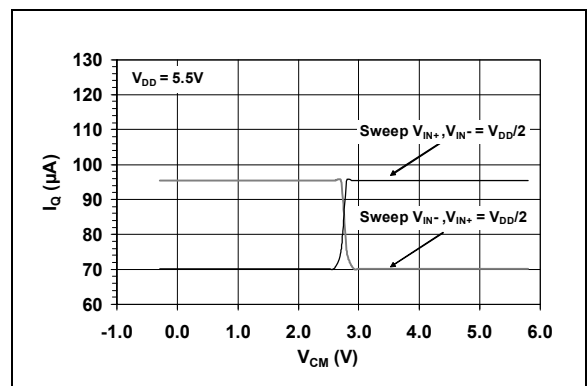
**FIGURE 2-14:** Quiescent Current.



**FIGURE 2-17:** Quiescent Current vs. Supply Voltage vs. Temperature.



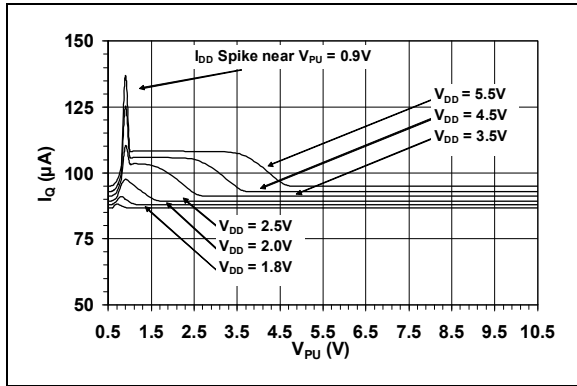
**FIGURE 2-15:** Quiescent Current vs. Common-mode Input Voltage.



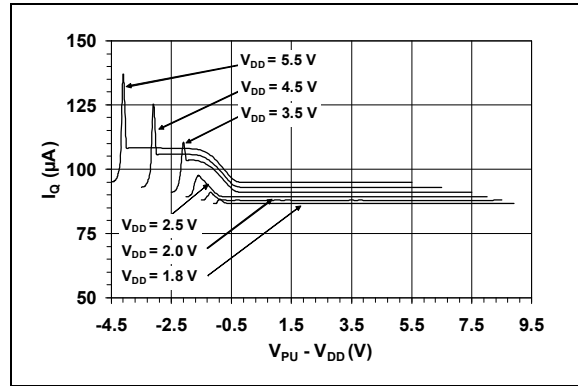
**FIGURE 2-18:** Quiescent Current vs. Common-mode Input Voltage.

# MCP6566/6R/6U/7/9

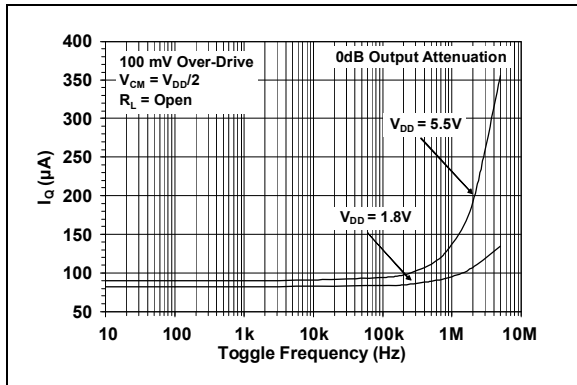
**Note:** Unless otherwise indicated,  $V_{DD} = +1.8V$  to  $+5.5V$ ,  $V_{SS} = GND$ ,  $T_A = +25^\circ C$ ,  $V_{IN+} = V_{DD}/2$ ,  $V_{IN-} = GND$ ,  $R_L = 20\ k\Omega$  to  $V_{PU} = V_{DD}$ , and  $C_L = 25\ pF$ .



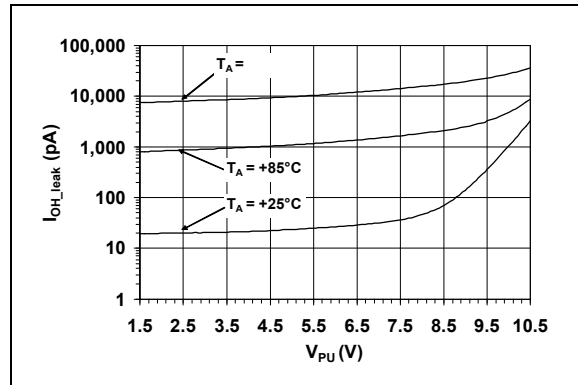
**FIGURE 2-19:** Quiescent Current vs. Pull-up Voltage.



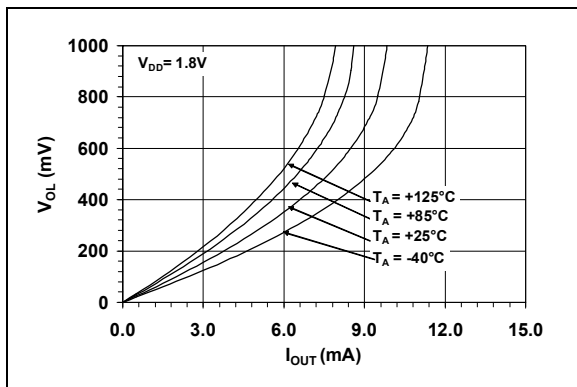
**FIGURE 2-22:** Quiescent Current vs. Pull-up to Supply Voltage Difference.



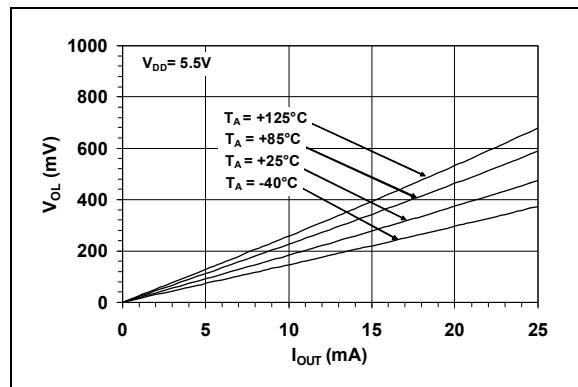
**FIGURE 2-20:** Quiescent Current vs. Toggle Frequency.



**FIGURE 2-23:** Output Leakage Current vs. Pull-up Voltage.



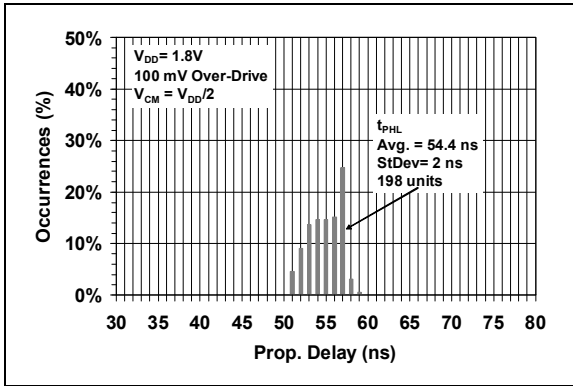
**FIGURE 2-21:** Output Headroom vs Output Current.



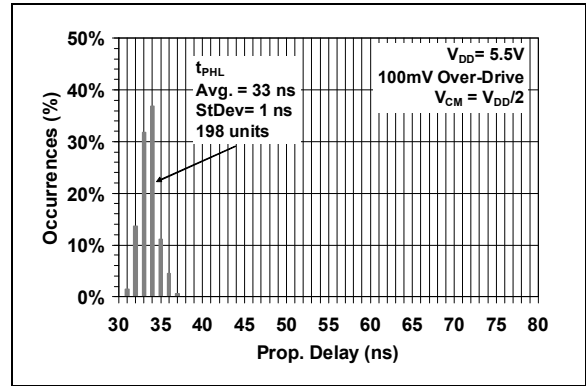
**FIGURE 2-24:** Output Headroom Vs Output Current.

# MCP6566/6R/6U/7/9

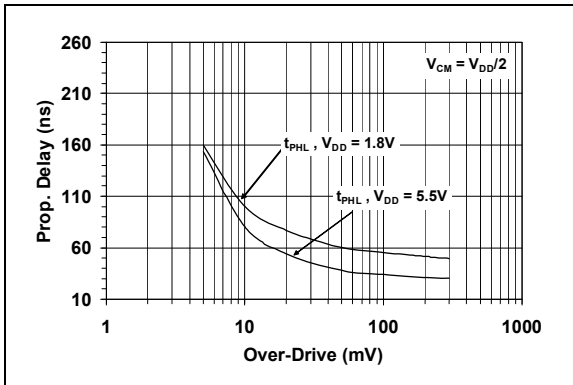
**Note:** Unless otherwise indicated,  $V_{DD} = +1.8V$  to  $+5.5V$ ,  $V_{SS} = GND$ ,  $T_A = +25^\circ C$ ,  $V_{IN+} = V_{DD}/2$ ,  $V_{IN-} = GND$ ,  $R_L = 20\text{ k}\Omega$  to  $V_{PU} = V_{DD}$ , and  $C_L = 25\text{ pF}$ .



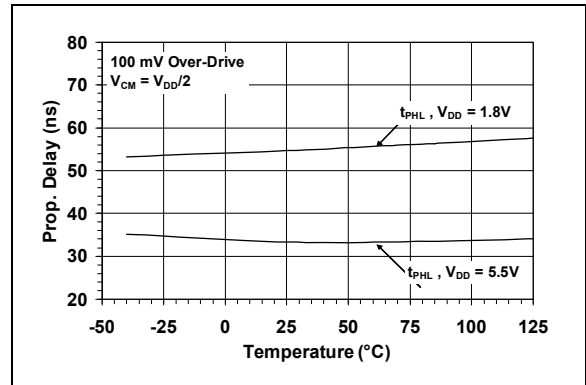
**FIGURE 2-25:** High-to-Low Propagation Delays.



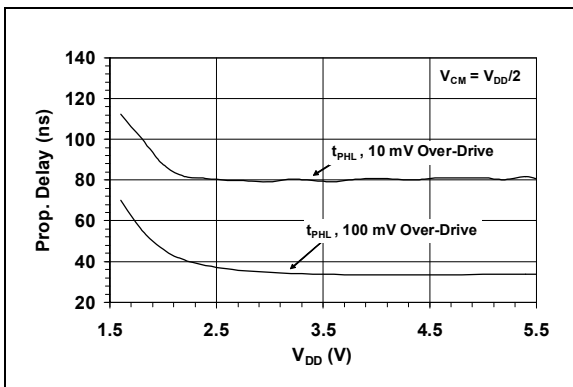
**FIGURE 2-28:** High-to-Low Propagation Delays.



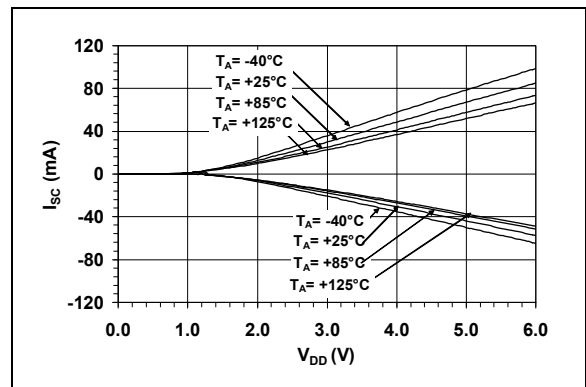
**FIGURE 2-26:** Propagation Delay vs. Input Over-Drive.



**FIGURE 2-29:** Propagation Delay vs. Temperature.



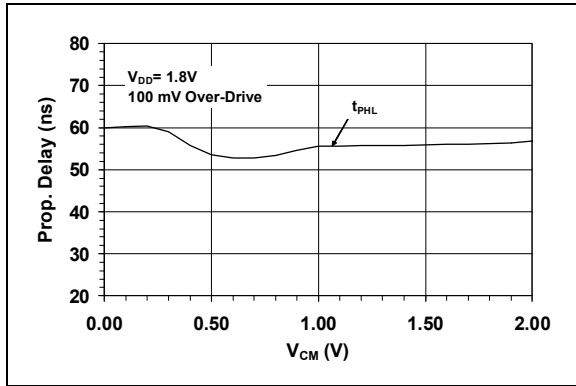
**FIGURE 2-27:** Propagation Delay vs. Supply Voltage.



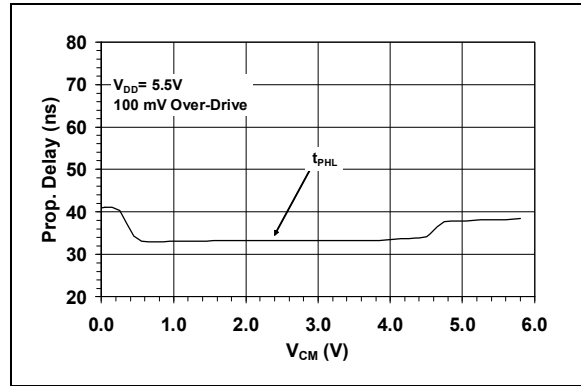
**FIGURE 2-30:** Short Circuit Current vs. Supply Voltage vs. Temperature.

# MCP6566/6R/6U/7/9

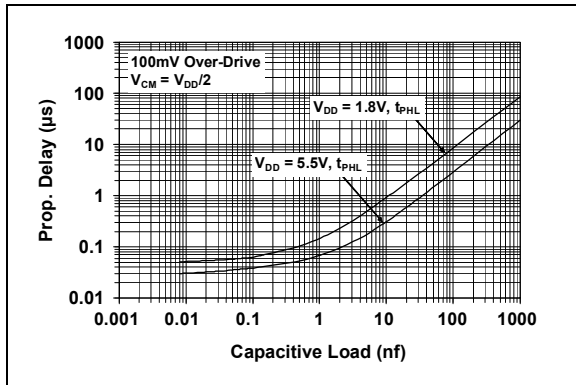
**Note:** Unless otherwise indicated,  $V_{DD} = +1.8\text{V}$  to  $+5.5\text{V}$ ,  $V_{SS} = \text{GND}$ ,  $T_A = +25^\circ\text{C}$ ,  $V_{IN+} = V_{DD}/2$ ,  $V_{IN-} = \text{GND}$ ,  $R_L = 20\text{ k}\Omega$  to  $V_{PU} = V_{DD}$ , and  $C_L = 25\text{ pF}$ .



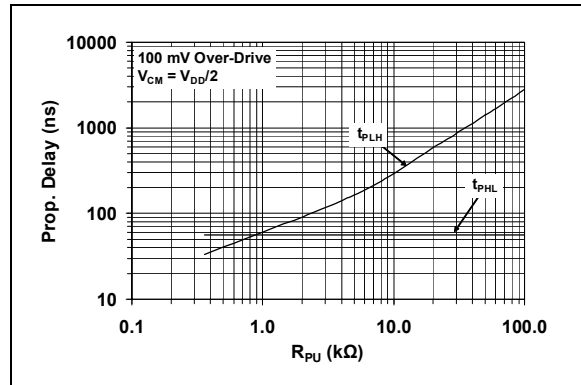
**FIGURE 2-31:** Propagation Delay vs. Common-mode Input Voltage.



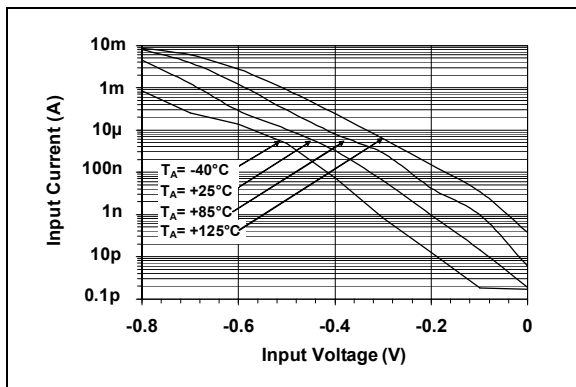
**FIGURE 2-34:** Propagation Delay vs. Common-mode Input Voltage.



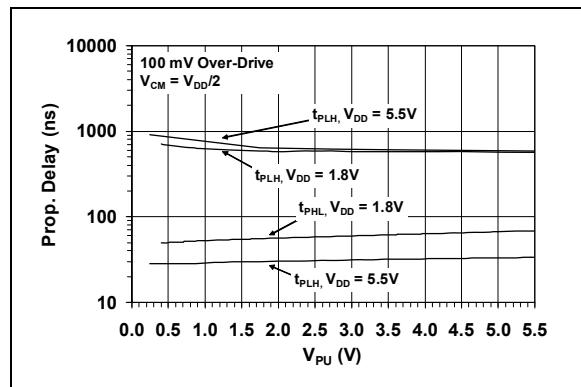
**FIGURE 2-32:** Propagation Delay vs. Capacitive Load.



**FIGURE 2-35:** Propagation Delay vs. Pull-up Resistor.

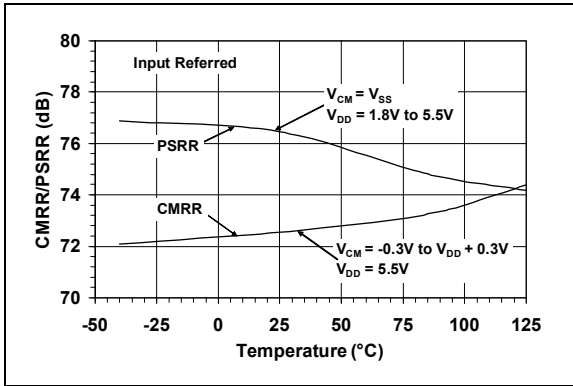


**FIGURE 2-33:** Input Bias Current vs. Input Voltage vs Temperature.

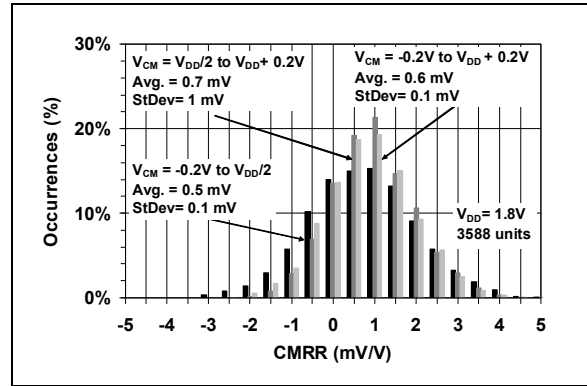


**FIGURE 2-36:** Propagation Delay vs. Pull-up Voltage.

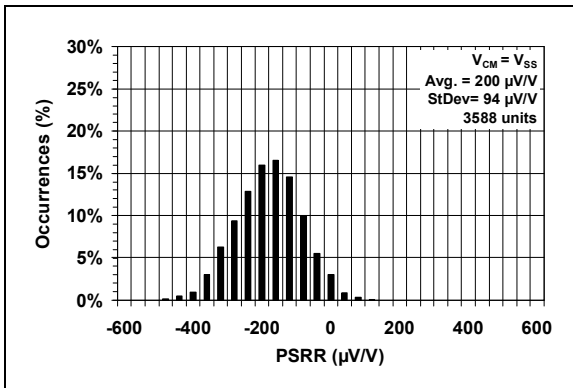
**Note:** Unless otherwise indicated,  $V_{DD} = +1.8V$  to  $+5.5V$ ,  $V_{SS} = GND$ ,  $T_A = +25^\circ C$ ,  $V_{IN+} = V_{DD}/2$ ,  $V_{IN-} = GND$ ,  $R_L = 20\text{ k}\Omega$  to  $V_{PU} = V_{DD}$ , and  $C_L = 25\text{ pF}$ .



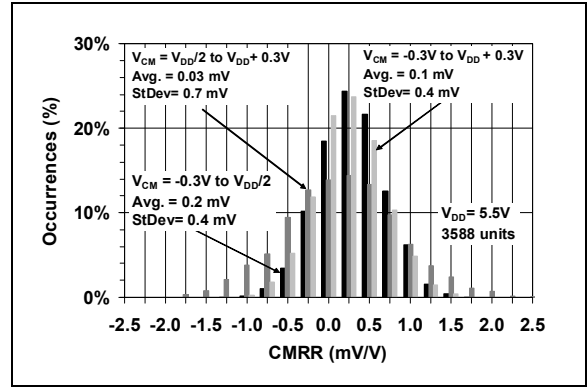
**FIGURE 2-37:** Common-mode Rejection Ratio and Power Supply Rejection Ratio vs. Temperature.



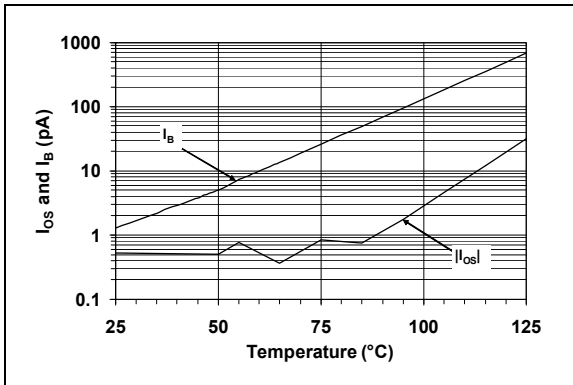
**FIGURE 2-40:** Common-mode Rejection Ratio (CMRR).



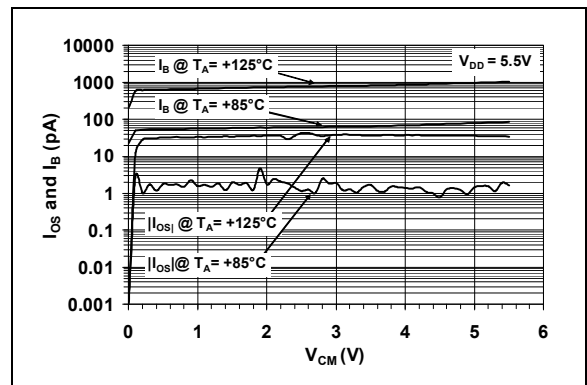
**FIGURE 2-38:** Power Supply Rejection Ratio (PSRR).



**FIGURE 2-41:** Common-mode Rejection Ratio (CMRR).



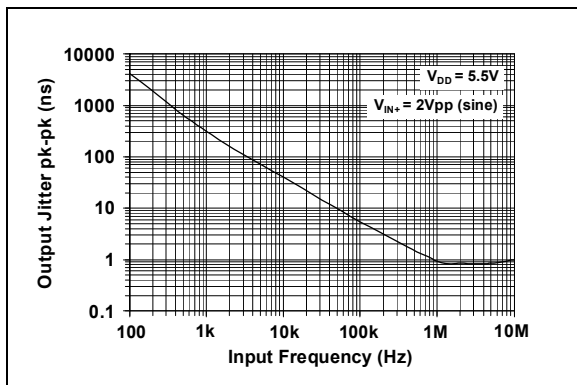
**FIGURE 2-39:** Input Offset Current and Input Bias Current vs. Temperature.



**FIGURE 2-42:** Input Offset Current and Input Bias Current vs. Common-mode Input Voltage vs. Temperature.

# MCP6566/6R/6U/7/9

**Note:** Unless otherwise indicated,  $V_{DD} = +1.8V$  to  $+5.5V$ ,  $V_{SS} = GND$ ,  $T_A = +25^\circ C$ ,  $V_{IN+} = V_{DD}/2$ ,  $V_{IN-} = GND$ ,  $R_L = 20\text{ k}\Omega$  to  $V_{PU} = V_{DD}$ , and  $C_L = 25\text{ pF}$ .



**FIGURE 2-43:** Output Jitter vs. Input Frequency.

## 3.0 PIN DESCRIPTIONS

Descriptions of the pins are listed in [Table 3-1](#).

**TABLE 3-1: PIN FUNCTION TABLE**

| MCP6566             | MCP6566R | MCP6566U | MCP6567       | MCP6569        | Symbol                 | Description                        |
|---------------------|----------|----------|---------------|----------------|------------------------|------------------------------------|
| SC70-5,<br>SOT-23-5 | SOT-23-5 | SOT-23-5 | MSOP,<br>SOIC | SOIC,<br>TSSOP |                        |                                    |
| 1                   | 1        | 5        | 1             | 1              | OUT, OUTA              | Digital Output (comparator A)      |
| 4                   | 4        | 3        | 2             | 2              | $V_{IN-}$ , $V_{INA-}$ | Inverting Input (comparator A)     |
| 3                   | 3        | 1        | 3             | 3              | $V_{IN+}$ , $V_{INA+}$ | Non-inverting Input (comparator A) |
| 5                   | 2        | 4        | 8             | 4              | $V_{DD}$               | Positive Power Supply              |
| —                   | —        | —        | 5             | 5              | $V_{INB+}$             | Non-inverting Input (comparator B) |
| —                   | —        | —        | 6             | 6              | $V_{INB-}$             | Inverting Input (comparator B)     |
| —                   | —        | —        | 7             | 7              | OUTB                   | Digital Output (comparator B)      |
| —                   | —        | —        | —             | 8              | OUTC                   | Digital Output (comparator C)      |
| —                   | —        | —        | —             | 9              | $V_{INC-}$             | Inverting Input (comparator C)     |
| —                   | —        | —        | —             | 10             | $V_{INC+}$             | Non-inverting Input (comparator C) |
| 2                   | 5        | 2        | 4             | 11             | $V_{SS}$               | Negative Power Supply              |
| —                   | —        | —        | —             | 12             | $V_{IND+}$             | Non-inverting Input (comparator D) |
| —                   | —        | —        | —             | 13             | $V_{IND-}$             | Inverting Input (comparator D)     |
| —                   | —        | —        | —             | 14             | OUTD                   | Digital Output (comparator D)      |

### 3.1 Analog Inputs

The comparator non-inverting and inverting inputs are high-impedance CMOS inputs with low bias currents.

### 3.2 Digital Outputs

The comparator outputs are CMOS, open-drain digital outputs. They are designed to make level shifting and wired-OR easy to implement.

### 3.3 Power Supply ( $V_{SS}$ and $V_{DD}$ )

The positive power supply pin ( $V_{DD}$ ) is 1.8V to 5.5V higher than the negative power supply pin ( $V_{SS}$ ). For normal operation, the other pins are at voltages between  $V_{SS}$  and  $V_{DD}$ .

Typically, these parts are used in a single (positive) supply configuration. In this case,  $V_{SS}$  is connected to ground and  $V_{DD}$  is connected to the supply.  $V_{DD}$  will need a local bypass capacitor (typically 0.01  $\mu$ F to 0.1  $\mu$ F) within 2 mm of the  $V_{DD}$  pin. These can share a bulk capacitor with nearby analog parts (within 100 mm), but it is not required.

# MCP6566/6R/6U/7/9

---

NOTES:



## 4.0 APPLICATIONS INFORMATION

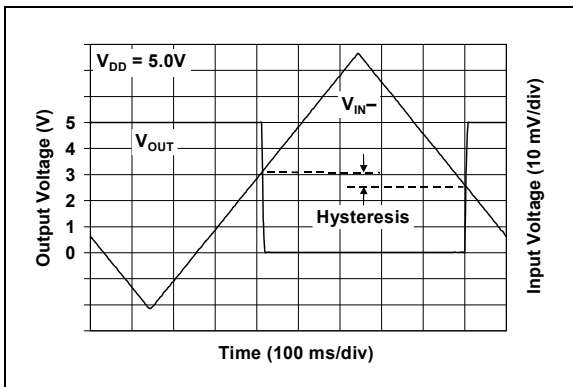
The MCP6566/6R/6U/7/9 family of open-drain output comparators are fabricated on Microchip's state-of-the-art CMOS process. They are suitable for a wide range of high speed applications requiring low-power consumption.

### 4.1 Comparator Inputs

#### 4.1.1 NORMAL OPERATION

The input stage of this family of devices uses two differential input stages in parallel. This configuration provides three regions of operation, one operates at low input voltages, one at high input voltages, and one at mid input voltage. With this topology, the input voltage range is 0.3V above  $V_{DD}$  and 0.3V below  $V_{SS}$ , while providing low offset voltage throughout the common mode range. The input offset voltage is measured at both  $V_{SS} - 0.3V$  and  $V_{DD} + 0.3V$  to ensure proper operation.

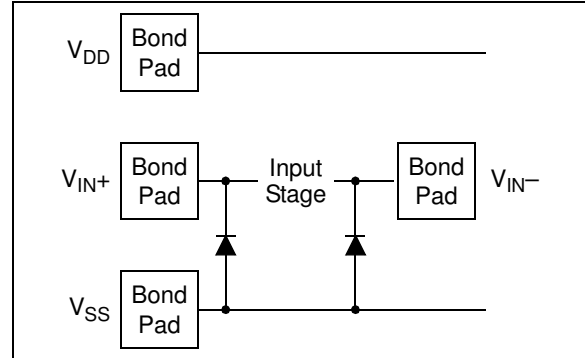
The MCP6566/6R/6U/7/9 family has internally-set hysteresis  $V_{HYST}$  that is small enough to maintain input offset accuracy and large enough to eliminate output chattering caused by the comparator's own input noise voltage  $E_{NI}$ . Figure 4-1 depicts this behavior. Input offset voltage ( $V_{OS}$ ) is the center (average) of the (input-referred) low-high and high-low trip points. Input hysteresis voltage ( $V_{HYST}$ ) is the difference between the same trip points.



**FIGURE 4-1:** The MCP6566/6R/6U/7/9 comparators' internal hysteresis eliminates output chatter caused by input noise voltage.

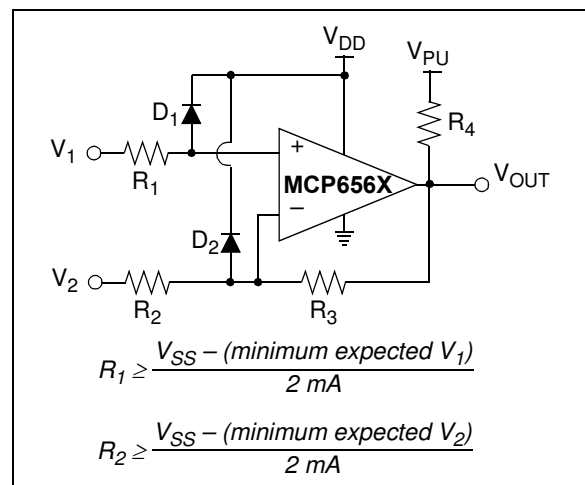
#### 4.1.2 INPUT VOLTAGE AND CURRENT LIMITS

The ESD protection on the inputs can be depicted as shown in Figure 4-2. This structure was chosen to protect the input transistors, and to minimize input bias current ( $I_B$ ). The input ESD diodes clamp the inputs when they try to go more than one diode drop below  $V_{SS}$ . They also clamp any voltages that go too far above  $V_{DD}$ ; their breakdown voltage is high enough to allow normal operation, and low enough to bypass ESD events within the specified limits.



**FIGURE 4-2:** Simplified Analog Input ESD Structures.

In order to prevent damage and/or improper operation of these amplifiers, the circuits they are in must limit the currents (and voltages) at the  $V_{IN+}$  and  $V_{IN-}$  pins (see Section 1.1 "Maximum Ratings" at the beginning of Section 1.0 "Electrical Characteristics"). Figure 4-3 shows the recommended approach to protecting these inputs. The internal ESD diodes prevent the input pins ( $V_{IN+}$  and  $V_{IN-}$ ) from going too far below ground, and the resistors  $R_1$  and  $R_2$  limit the possible current drawn out of the input pin. Diodes  $D_1$  and  $D_2$  prevent the input pin ( $V_{IN+}$  and  $V_{IN-}$ ) from going too far above  $V_{DD}$ . When implemented as shown, resistors  $R_1$  and  $R_2$  also limit the current through  $D_1$  and  $D_2$ .



**FIGURE 4-3:** Protecting the Analog Inputs.

# MCP6566/6R/6U/7/9

It is also possible to connect the diodes to the left of the resistors  $R_1$  and  $R_2$ . In this case, the currents through the diodes  $D_1$  and  $D_2$  need to be limited by some other mechanism. The resistor then serves as in-rush current limiter; the DC current into the input pins ( $V_{IN+}$  and  $V_{IN-}$ ) should be very small.

A significant amount of current can flow out of the inputs when the common mode voltage ( $V_{CM}$ ) is below ground ( $V_{SS}$ ); see [Figure 4-3](#). Applications that are high-impedance may need to limit the usable voltage range.

## 4.1.3 PHASE REVERSAL

The MCP6566/6R/6U/7/9 comparator family uses CMOS transistors at the input. They are designed to prevent phase inversion when the input pins exceed the supply voltages. [Figure 2-3](#) shows an input voltage exceeding both supplies with no resulting phase inversion.

## 4.2 Open-Drain Output

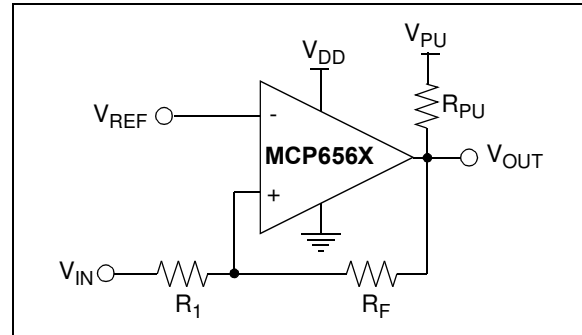
The open-drain output is designed to make level-shifting and wired-OR logic easy to implement. The output stage minimizes switching current (shoot-through current from supply-to-supply) when the output changes state. See [Figures 2-15, 2-18, 2-35](#) and [2-36](#), for more information.

## 4.3 Externally Set Hysteresis

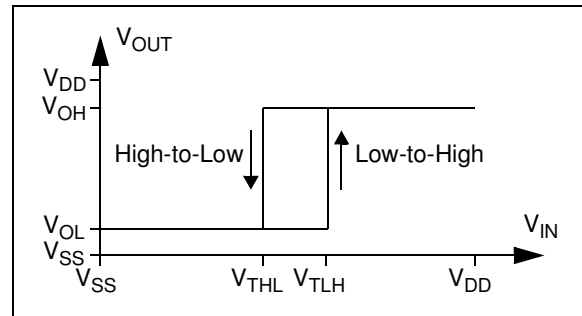
Greater flexibility in selecting hysteresis (or input trip points) is achieved by using external resistors. Hysteresis reduces output chattering when one input is slowly moving past the other. It also helps in systems where it is best not to cycle between high and low states too frequently (e.g., air conditioner thermostatic control). Output chatter also increases the dynamic supply current.

### 4.3.1 NON-INVERTING CIRCUIT

[Figure 4-4](#) shows a non-inverting circuit for single-supply applications using just two resistors. The resulting hysteresis diagram is shown in [Figure 4-5](#).



**FIGURE 4-4:** Non-Inverting Circuit with Hysteresis for Single-Supply.



**FIGURE 4-5:** Hysteresis Diagram for the Non-Inverting Circuit.

The trip points for [Figures 4-4](#) and [4-5](#) are:

### EQUATION 4-1:

$$V_{TLH} = V_{REF} \left( 1 + \frac{R_I}{R_F} \right) - V_{OL} \left( \frac{R_I}{R_F} \right)$$

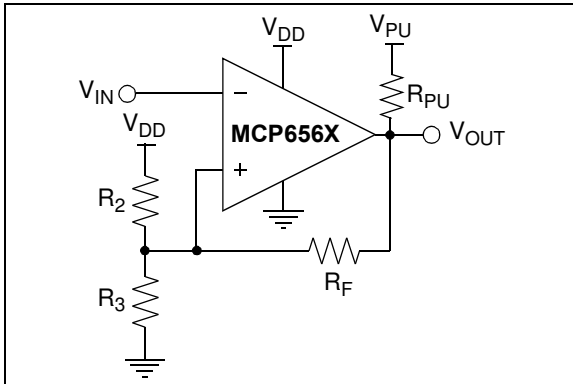
$$V_{THL} = V_{REF} \left( 1 + \frac{R_I}{R_F} \right) - V_{OH} \left( \frac{R_I}{R_F} \right)$$

Where:

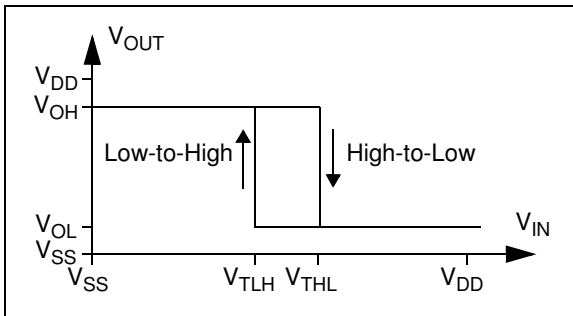
$V_{TLH}$  = trip voltage from low-to-high  
 $V_{THL}$  = trip voltage from high-to-low

## 4.3.2 INVERTING CIRCUIT

Figure 4-6 shows an inverting circuit for single-supply using three resistors. The resulting hysteresis diagram is shown in Figure 4-7.

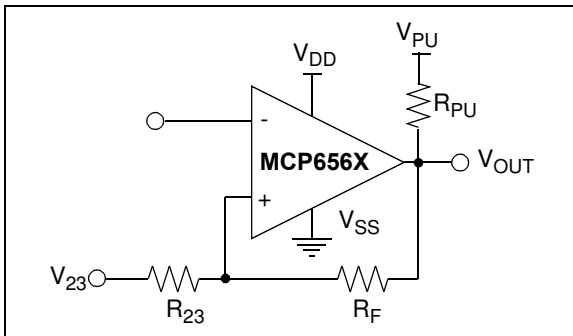


**FIGURE 4-6:** Inverting Circuit with Hysteresis.



**FIGURE 4-7:** Hysteresis Diagram for the Inverting Circuit.

In order to determine the trip voltages ( $V_{THL}$  and  $V_{TLH}$ ) for the circuit shown in Figure 4-6,  $R_2$  and  $R_3$  can be simplified to the Thevenin equivalent circuit with respect to  $V_{DD}$ , as shown in Figure 4-8.



**FIGURE 4-8:** Thevenin Equivalent Circuit.

Where:

$$R_{23} = \frac{R_2 R_3}{R_2 + R_3}$$

$$V_{23} = \frac{R_3}{R_2 + R_3} \times V_{DD}$$

Using this simplified circuit, the trip voltage can be calculated using the following equation:

### EQUATION 4-2:

$$V_{THL} = V_{OH} \left( \frac{R_{23}}{R_{23} + R_F} \right) + V_{23} \left( \frac{R_F}{R_{23} + R_F} \right)$$

$$V_{TLH} = V_{OL} \left( \frac{R_{23}}{R_{23} + R_F} \right) + V_{23} \left( \frac{R_F}{R_{23} + R_F} \right)$$

Where:

$V_{TLH}$  = trip voltage from low-to-high

$V_{THL}$  = trip voltage from high-to-low

Figure 2-21 and Figure 2-24 can be used to determine typical values for  $V_{OH}$  and  $V_{OL}$ .

## 4.4 Bypass Capacitors

With this family of comparators, the power supply pin ( $V_{DD}$  for single supply) should have a local bypass capacitor (i.e., 0.01  $\mu\text{F}$  to 0.1  $\mu\text{F}$ ) within 2 mm for good edge rate performance.

## 4.5 Capacitive Loads

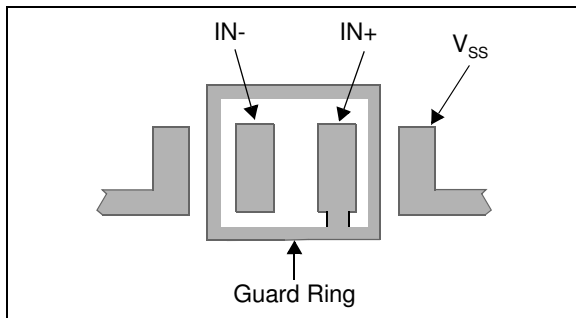
Reasonable capacitive loads (e.g., logic gates) have little impact on propagation delay (see Figure 2-32). The supply current increases with increasing toggle frequency (Figure 2-20), especially with higher capacitive loads. The output slew rate and propagation delay performance will be reduced with higher capacitive loads.

# MCP6566/6R/6U/7/9

## 4.6 PCB Surface Leakage

In applications where low input bias current is critical, PCB (Printed Circuit Board) surface leakage effects need to be considered. Surface leakage is caused by humidity, dust or other contamination on the board. Under low humidity conditions, a typical resistance between nearby traces is  $10^{12}\Omega$ . A 5V difference would cause 5 pA of current to flow. This is greater than the MCP6566/6R/6U/7/9 family's bias current at +25°C (1 pA, typical).

The easiest way to reduce surface leakage is to use a guard ring around sensitive pins (or traces). The guard ring is biased at the same voltage as the sensitive pin. An example of this type of layout is shown in Figure 4-9.

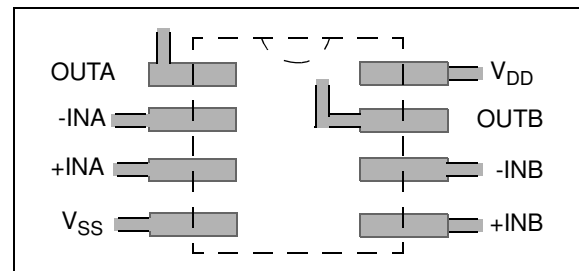


**FIGURE 4-9:** Example Guard Ring Layout for Inverting Circuit.

1. Inverting Configuration (Figures 4-6 and 4-9):
  - a) Connect the guard ring to the non-inverting input pin ( $V_{IN+}$ ). This biases the guard ring to the same reference voltage as the comparator (e.g.,  $V_{DD}/2$  or ground).
  - b) Connect the inverting pin ( $V_{IN-}$ ) to the input pad without touching the guard ring.
2. Non-inverting Configuration (Figure 4-4):
  - a) Connect the non-inverting pin ( $V_{IN+}$ ) to the input pad without touching the guard ring.
  - b) Connect the guard ring to the inverting input pin ( $V_{IN-}$ ).

## 4.7 PCB Layout Technique

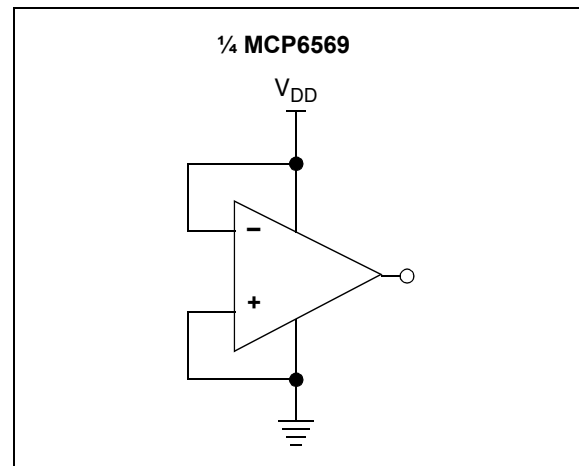
When designing the PCB layout it is critical to note that analog and digital signal traces are adequately separated to prevent signal coupling. If the comparator output trace is at close proximity to the input traces then large output voltage changes from,  $V_{SS}$  to  $V_{DD}$  or visa versa, may couple to the inputs and cause the device output to oscillate. To prevent such oscillation, the output traces must be routed away from the input pins. The SC70-5 and SOT-23-5 are relatively immune because the output pin OUT (pin 1) is separated by the power pin  $V_{DD}/V_{SS}$  (pin 2) from the input pin +IN (as long as the analog and digital traces remain separated throughout the PCB). However, the pinouts for the dual and quad packages (SOIC, MSOP, TSSOP) have OUT and -IN pins (pin 1 and 2) close to each other. The recommended layout for these packages is shown in Figure 4-10.



**FIGURE 4-10:** Recommended Layout.

## 4.8 Unused Comparators

An unused amplifier in a quad package (MCP6569) should be configured as shown in Figure 4-11. This circuit prevents the output from toggling and causing crosstalk. It uses the minimum number of components and draws minimal current (see Figure 2-15 and Figure 2-15).

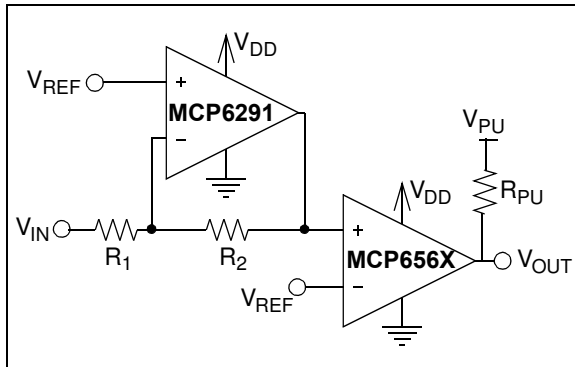


**FIGURE 4-11:** Unused Comparators.

## 4.9 Typical Applications

### 4.9.1 PRECISE COMPARATOR

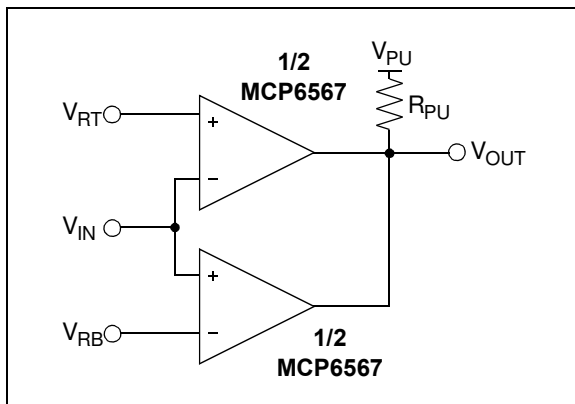
Some applications require higher DC precision. An easy way to solve this problem is to use an amplifier (such as the MCP6291) to gain-up the input signal before it reaches the comparator. Figure 4-12 shows an example of this approach.



**FIGURE 4-12:** Precise Inverting Comparator.

### 4.9.2 WINDOWED COMPARATOR

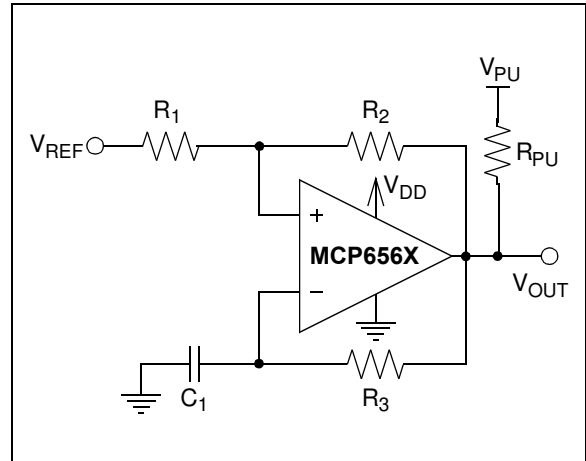
Figure 4-13 shows one approach to designing a windowed comparator. The AND gate produces a logic '1' when the input voltage is between  $V_{RB}$  and  $V_{RT}$  (where  $V_{RT} > V_{RB}$ ).



**FIGURE 4-13:** Windowed Comparator.

### 4.9.3 BISTABLE MULTI-VIBRATOR

A simple bistable multi-vibrator design is shown in Figure 4-14.  $V_{REF}$  needs to be between the power supplies ( $V_{SS} = GND$  and  $V_{DD}$ ) to achieve oscillation. The output duty cycle changes with  $V_{REF}$ .



**FIGURE 4-14:** Bistable Multi-vibrator.

# MCP6566/6R/6U/7/9

---

NOTES:

## 5.0 DESIGN AIDS

### 5.1 Microchip Advanced Part Selector (MAPS)

MAPS is a software tool that helps semiconductor professionals efficiently identify Microchip devices that fit a particular design requirement. Available at no cost from the Microchip web site at [www.microchip.com/maps](http://www.microchip.com/maps), the MAPS is an overall selection tool for Microchip's product portfolio that includes Analog, Memory, MCUs and DSCs. Using this tool you can define a filter to sort features for a parametric search of devices and export side-by-side technical comparison reports. Helpful links are also provided for Data Sheets, Purchase, and Sampling of Microchip parts.

### 5.2 Analog Demonstration and Evaluation Boards

Microchip offers a broad spectrum of Analog Demonstration and Evaluation Boards that are designed to help you achieve faster time to market. For a complete listing of these boards and their corresponding user's guides and technical information, visit the Microchip web site at [www.microchip.com/analogtools](http://www.microchip.com/analogtools). Three of our boards that are especially useful are:

- 8-Pin SOIC/MSOP/TSSOP/DIP Evaluation Board, P/N SOIC8EV
- 14-Pin SOIC/TSSOP/DIP Evaluation Board, P/N SOIC14EV
- 5/6-Pin SOT23 Evaluation Board, P/N VSUPEV2

## 5.3 Application Notes

The following Microchip Application Notes are available on the Microchip web site at [www.microchip.com](http://www.microchip.com) and are recommended as supplemental reference resources:

- **AN895**, "*Oscillator Circuit For RTD Temperature Sensors*", DS00895.

# MCP6566/6R/6U/7/9

---

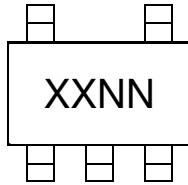
NOTES:



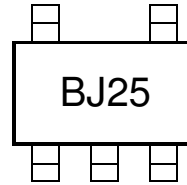
## 6.0 PACKAGING INFORMATION

### 6.1 Package Marking Information

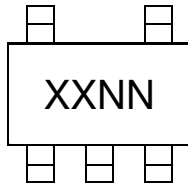
5-Lead SC70 (MCP6566)



Example:



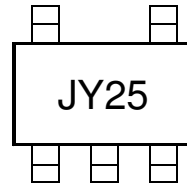
5-Lead SOT-23 (MCP6566, MCP6566R)



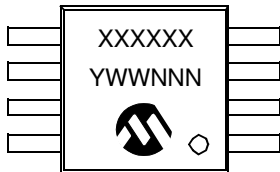
| Device    | Code |
|-----------|------|
| MCP6566T  | JYNN |
| MCP6566RT | JZNN |
| MCP6566UT | WLNN |

**Note:** Applies to 5-Lead SOT-23.

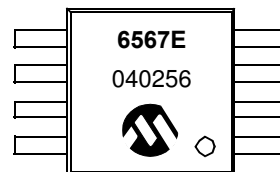
Example:



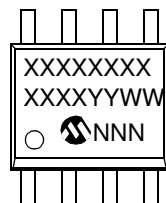
8-Lead MSOP (MCP6567)



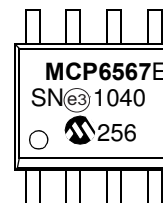
Example:



8-Lead SOIC (150 mil) (MCP6567)



Example:



|                |        |                                                                                                                  |
|----------------|--------|------------------------------------------------------------------------------------------------------------------|
| <b>Legend:</b> | XX...X | Customer-specific information                                                                                    |
|                | Y      | Year code (last digit of calendar year)                                                                          |
|                | YY     | Year code (last 2 digits of calendar year)                                                                       |
|                | WW     | Week code (week of January 1 is week '01')                                                                       |
|                | NNN    | Alphanumeric traceability code                                                                                   |
|                | (e3)   | Pb-free JEDEC designator for Matte Tin (Sn)                                                                      |
|                | *      | This package is Pb-free. The Pb-free JEDEC designator (e3) can be found on the outer packaging for this package. |

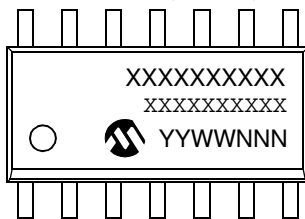
**Note:** In the event the full Microchip part number cannot be marked on one line, it will be carried over to the next line, thus limiting the number of available characters for customer-specific information.

# MCP6566/6R/6U/7/9

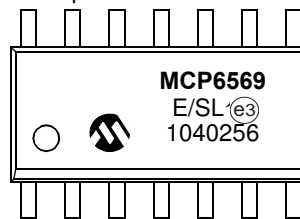
---

## Package Marking Information (Continued)

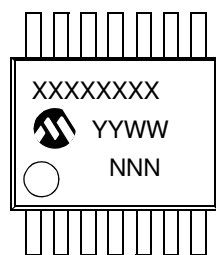
14-Lead SOIC (150 mil) (MCP6569)



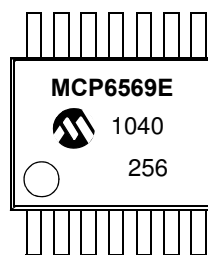
Example:



14-Lead TSSOP (MCP6569)

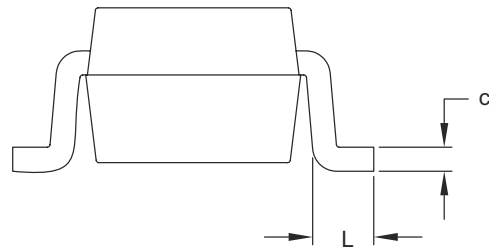
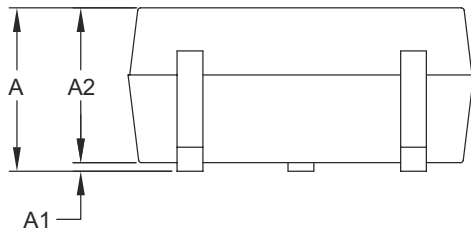
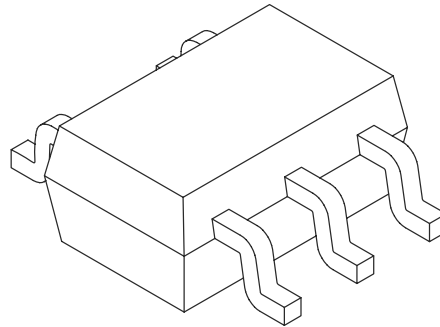
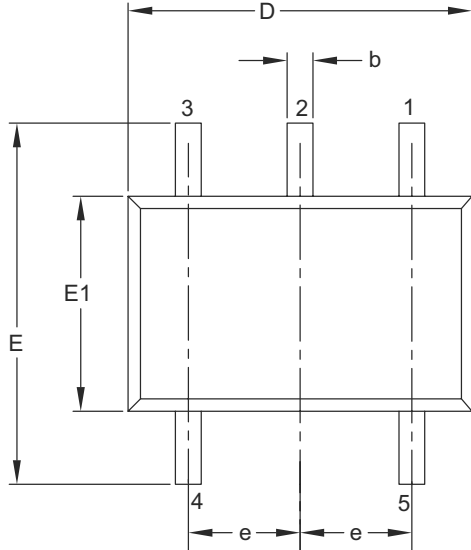


Example:



## 5-Lead Plastic Small Outline Transistor (LT) [SC70]

**Note:** For the most current package drawings, please see the Microchip Packaging Specification located at <http://www.microchip.com/packaging>



| Dimension Limits         | Units | MILLIMETERS |      |      |
|--------------------------|-------|-------------|------|------|
|                          |       | MIN         | NOM  | MAX  |
| Number of Pins           | N     | 5           |      |      |
| Pitch                    | e     | 0.65 BSC    |      |      |
| Overall Height           | A     | 0.80        | –    | 1.10 |
| Molded Package Thickness | A2    | 0.80        | –    | 1.00 |
| Standoff                 | A1    | 0.00        | –    | 0.10 |
| Overall Width            | E     | 1.80        | 2.10 | 2.40 |
| Molded Package Width     | E1    | 1.15        | 1.25 | 1.35 |
| Overall Length           | D     | 1.80        | 2.00 | 2.25 |
| Foot Length              | L     | 0.10        | 0.20 | 0.46 |
| Lead Thickness           | c     | 0.08        | –    | 0.26 |
| Lead Width               | b     | 0.15        | –    | 0.40 |

**Notes:**

- Dimensions D and E1 do not include mold flash or protrusions. Mold flash or protrusions shall not exceed 0.127 mm per side.
- Dimensioning and tolerancing per ASME Y14.5M.

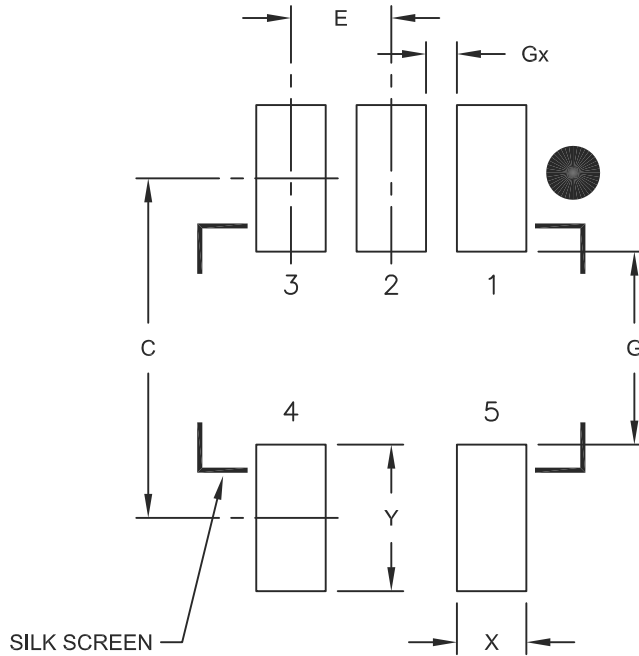
BSC: Basic Dimension. Theoretically exact value shown without tolerances.

Microchip Technology Drawing C04-061B

# MCP6566/6R/6U/7/9

## 5-Lead Plastic Small Outline Transistor (LT) [SC70]

**Note:** For the most current package drawings, please see the Microchip Packaging Specification located at <http://www.microchip.com/packaging>



RECOMMENDED LAND PATTERN

| Dimension Limits      | Units | MILLIMETERS |      |      |
|-----------------------|-------|-------------|------|------|
|                       |       | MIN         | NOM  | MAX  |
| Contact Pitch         | E     | 0.65 BSC    |      |      |
| Contact Pad Spacing   | C     |             | 2.20 |      |
| Contact Pad Width     | X     |             |      | 0.45 |
| Contact Pad Length    | Y     |             |      | 0.95 |
| Distance Between Pads | G     | 1.25        |      |      |
| Distance Between Pads | Gx    | 0.20        |      |      |

Notes:

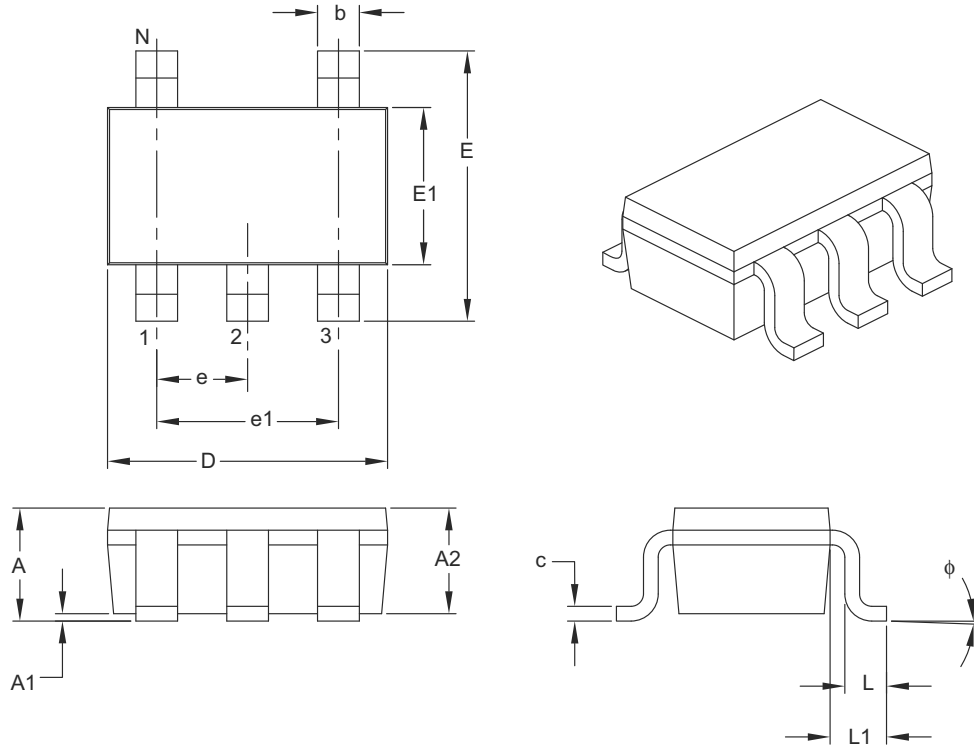
1. Dimensioning and tolerancing per ASME Y14.5M

BSC: Basic Dimension. Theoretically exact value shown without tolerances.

Microchip Technology Drawing No. C04-2061A

## 5-Lead Plastic Small Outline Transistor (OT) [SOT-23]

**Note:** For the most current package drawings, please see the Microchip Packaging Specification located at <http://www.microchip.com/packaging>



| Dimension Limits         | Units  | MILLIMETERS |     |      |
|--------------------------|--------|-------------|-----|------|
|                          |        | MIN         | NOM | MAX  |
| Number of Pins           | N      | 5           |     |      |
| Lead Pitch               | e      | 0.95 BSC    |     |      |
| Outside Lead Pitch       | e1     | 1.90 BSC    |     |      |
| Overall Height           | A      | 0.90        | –   | 1.45 |
| Molded Package Thickness | A2     | 0.89        | –   | 1.30 |
| Standoff                 | A1     | 0.00        | –   | 0.15 |
| Overall Width            | E      | 2.20        | –   | 3.20 |
| Molded Package Width     | E1     | 1.30        | –   | 1.80 |
| Overall Length           | D      | 2.70        | –   | 3.10 |
| Foot Length              | L      | 0.10        | –   | 0.60 |
| Footprint                | L1     | 0.35        | –   | 0.80 |
| Foot Angle               | $\phi$ | 0°          | –   | 30°  |
| Lead Thickness           | c      | 0.08        | –   | 0.26 |
| Lead Width               | b      | 0.20        | –   | 0.51 |

**Notes:**

- Dimensions D and E1 do not include mold flash or protrusions. Mold flash or protrusions shall not exceed 0.127 mm per side.
- Dimensioning and tolerancing per ASME Y14.5M.

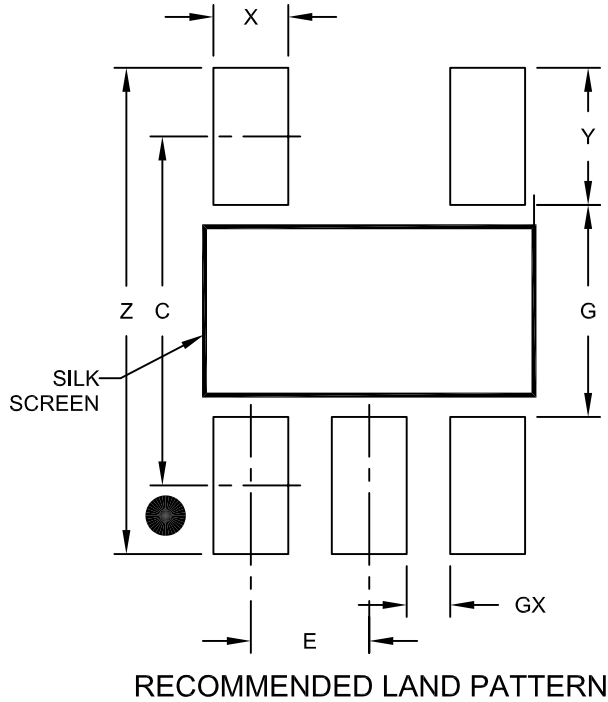
BSC: Basic Dimension. Theoretically exact value shown without tolerances.

Microchip Technology Drawing C04-091B

# MCP6566/6R/6U/7/9

## 5-Lead Plastic Small Outline Transistor (OT) [SOT-23]

**Note:** For the most current package drawings, please see the Microchip Packaging Specification located at <http://www.microchip.com/packaging>



| Dimension Limits        | Units | MILLIMETERS |      |      |
|-------------------------|-------|-------------|------|------|
|                         |       | MIN         | NOM  | MAX  |
| Contact Pitch           | E     | 0.95 BSC    |      |      |
| Contact Pad Spacing     | C     |             | 2.80 |      |
| Contact Pad Width (X5)  | X     |             |      | 0.60 |
| Contact Pad Length (X5) | Y     |             |      | 1.10 |
| Distance Between Pads   | G     | 1.70        |      |      |
| Distance Between Pads   | GX    | 0.35        |      |      |
| Overall Width           | Z     |             |      | 3.90 |

**Notes:**

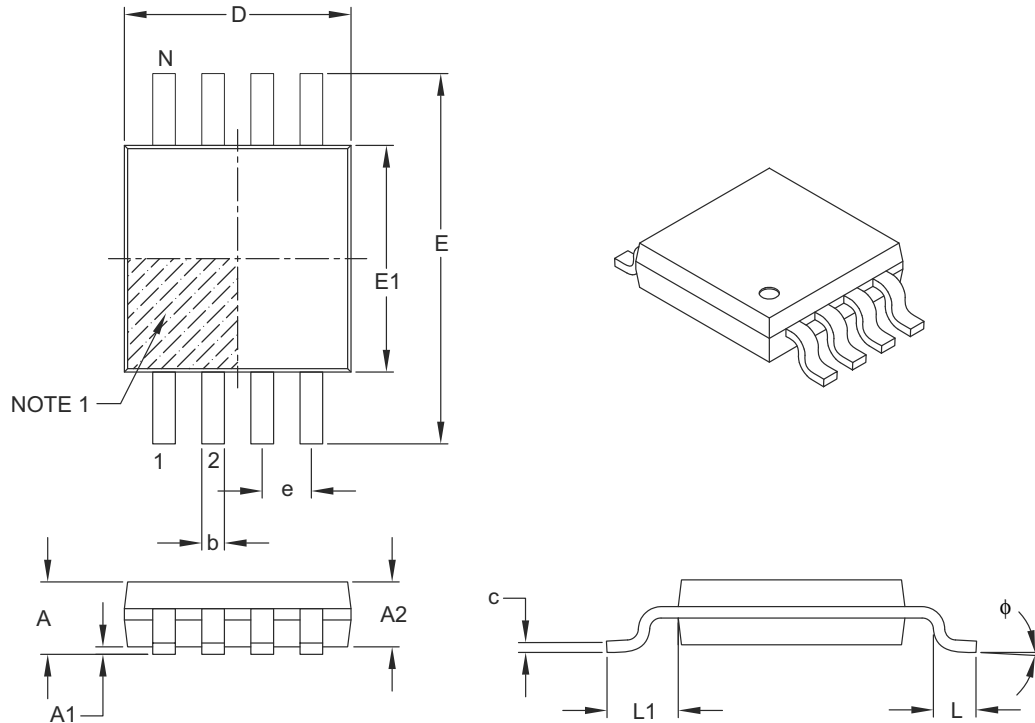
1. Dimensioning and tolerancing per ASME Y14.5M

BSC: Basic Dimension. Theoretically exact value shown without tolerances.

Microchip Technology Drawing No. C04-2091A

## 8-Lead Plastic Micro Small Outline Package (MS) [MSOP]

**Note:** For the most current package drawings, please see the Microchip Packaging Specification located at <http://www.microchip.com/packaging>



| Dimension Limits         | Units  | MILLIMETERS |      |      |
|--------------------------|--------|-------------|------|------|
|                          |        | MIN         | NOM  | MAX  |
| Number of Pins           | N      | 8           |      |      |
| Pitch                    | e      | 0.65 BSC    |      |      |
| Overall Height           | A      | –           | –    | 1.10 |
| Molded Package Thickness | A2     | 0.75        | 0.85 | 0.95 |
| Standoff                 | A1     | 0.00        | –    | 0.15 |
| Overall Width            | E      | 4.90 BSC    |      |      |
| Molded Package Width     | E1     | 3.00 BSC    |      |      |
| Overall Length           | D      | 3.00 BSC    |      |      |
| Foot Length              | L      | 0.40        | 0.60 | 0.80 |
| Footprint                | L1     | 0.95 REF    |      |      |
| Foot Angle               | $\phi$ | 0°          | –    | 8°   |
| Lead Thickness           | c      | 0.08        | –    | 0.23 |
| Lead Width               | b      | 0.22        | –    | 0.40 |

**Notes:**

- Pin 1 visual index feature may vary, but must be located within the hatched area.
- Dimensions D and E1 do not include mold flash or protrusions. Mold flash or protrusions shall not exceed 0.15 mm per side.
- Dimensioning and tolerancing per ASME Y14.5M.

BSC: Basic Dimension. Theoretically exact value shown without tolerances.

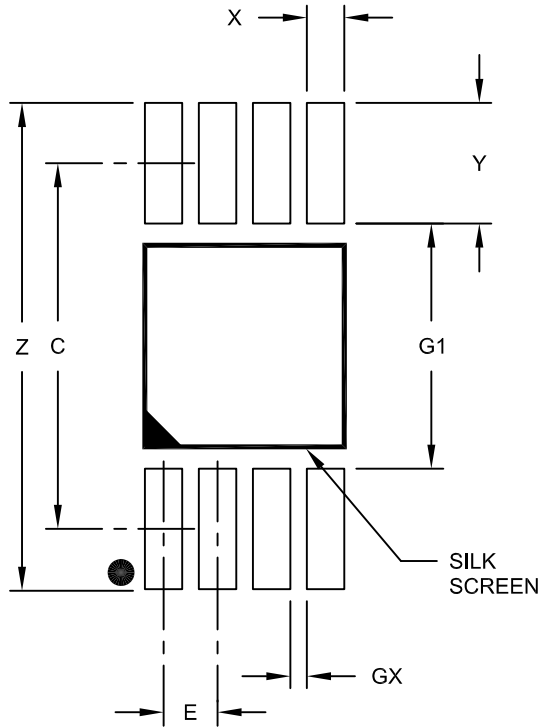
REF: Reference Dimension, usually without tolerance, for information purposes only.

Microchip Technology Drawing C04-111B

# MCP6566/6R/6U/7/9

## 8-Lead Plastic Micro Small Outline Package (MS) [MSOP]

**Note:** For the most current package drawings, please see the Microchip Packaging Specification located at <http://www.microchip.com/packaging>



RECOMMENDED LAND PATTERN

| Dimension Limits        | Units | MILLIMETERS |      |      |
|-------------------------|-------|-------------|------|------|
|                         |       | MIN         | NOM  | MAX  |
| Contact Pitch           | E     | 0.65 BSC    |      |      |
| Contact Pad Spacing     | C     |             | 4.40 |      |
| Overall Width           | Z     |             |      | 5.85 |
| Contact Pad Width (X8)  | X1    |             |      | 0.45 |
| Contact Pad Length (X8) | Y1    |             |      | 1.45 |
| Distance Between Pads   | G1    | 2.95        |      |      |
| Distance Between Pads   | Gx    | 0.20        |      |      |

**Notes:**

1. Dimensioning and tolerancing per ASME Y14.5M

BSC: Basic Dimension. Theoretically exact value shown without tolerances.

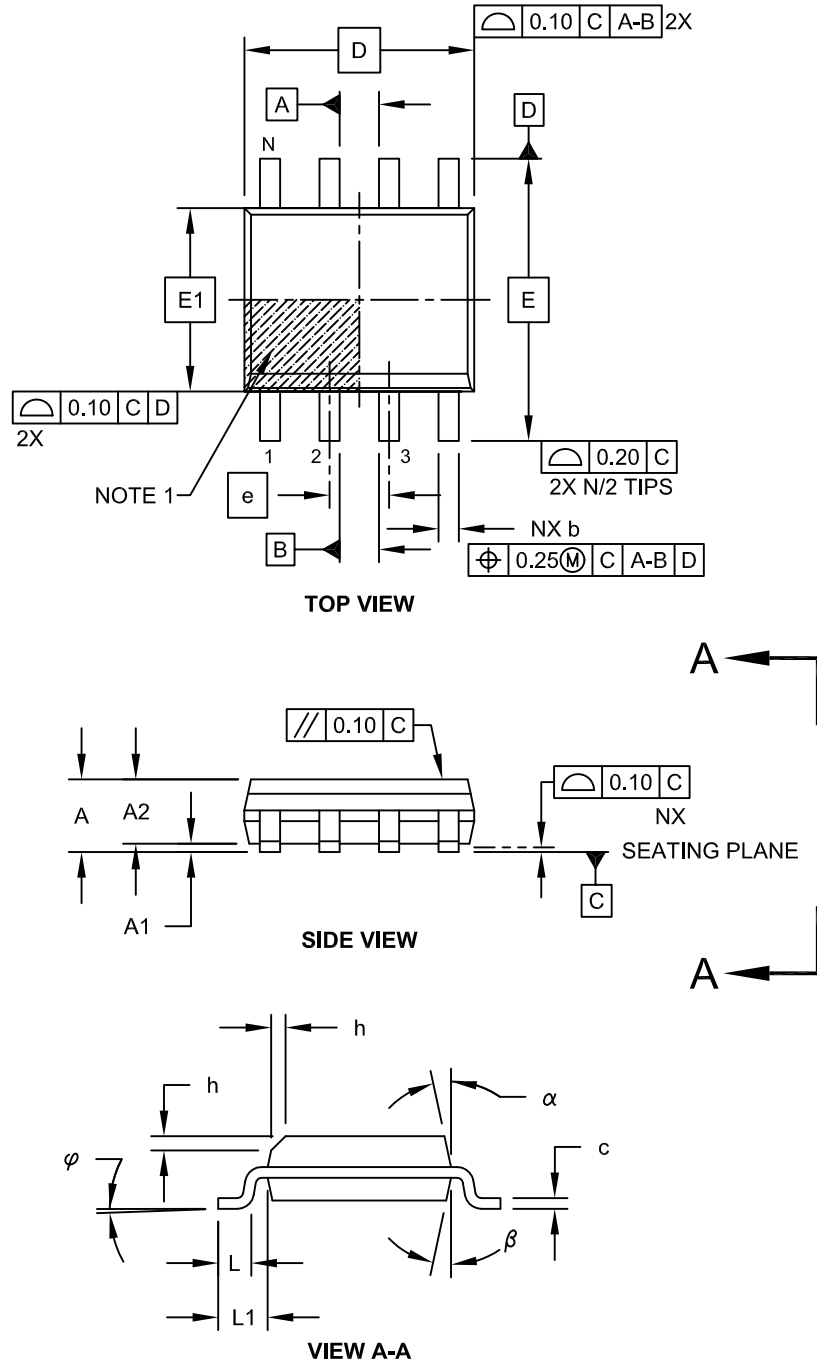
Microchip Technology Drawing No. C04-2111A



# MCP6566/6R/6U/7/9

## 8-Lead Plastic Small Outline (SN) - Narrow, 3.90 mm Body [SOIC]

**Note:** For the most current package drawings, please see the Microchip Packaging Specification located at <http://www.microchip.com/packaging>

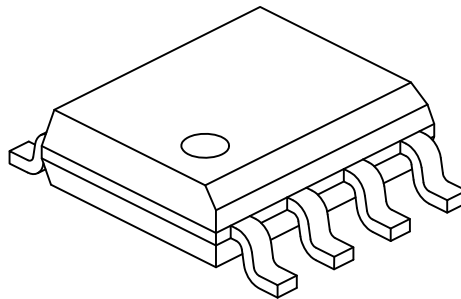


Microchip Technology Drawing No. C04-057C Sheet 1 of 2

# MCP6566/6R/6U/7/9

## 8-Lead Plastic Small Outline (SN) - Narrow, 3.90 mm Body [SOIC]

**Note:** For the most current package drawings, please see the Microchip Packaging Specification located at <http://www.microchip.com/packaging>



|                          |    | Units | MILLIMETERS |     |      |
|--------------------------|----|-------|-------------|-----|------|
| Dimension Limits         |    |       | MIN         | NOM | MAX  |
| Number of Pins           | N  |       | 8           |     |      |
| Pitch                    | e  |       | 1.27 BSC    |     |      |
| Overall Height           | A  |       | -           | -   | 1.75 |
| Molded Package Thickness | A2 |       | 1.25        | -   | -    |
| Standoff §               | A1 |       | 0.10        | -   | 0.25 |
| Overall Width            | E  |       | 6.00 BSC    |     |      |
| Molded Package Width     | E1 |       | 3.90 BSC    |     |      |
| Overall Length           | D  |       | 4.90 BSC    |     |      |
| Chamfer (Optional)       | h  |       | 0.25        | -   | 0.50 |
| Foot Length              | L  |       | 0.40        | -   | 1.27 |
| Footprint                | L1 |       | 1.04 REF    |     |      |
| Foot Angle               | φ  |       | 0°          | -   | 8°   |
| Lead Thickness           | c  |       | 0.17        | -   | 0.25 |
| Lead Width               | b  |       | 0.31        | -   | 0.51 |
| Mold Draft Angle Top     | α  |       | 5°          | -   | 15°  |
| Mold Draft Angle Bottom  | β  |       | 5°          | -   | 15°  |

### Notes:

1. Pin 1 visual index feature may vary, but must be located within the hatched area.
2. § Significant Characteristic
3. Dimensions D and E1 do not include mold flash or protrusions. Mold flash or protrusions shall not exceed 0.15mm per side.
4. Dimensioning and tolerancing per ASME Y14.5M

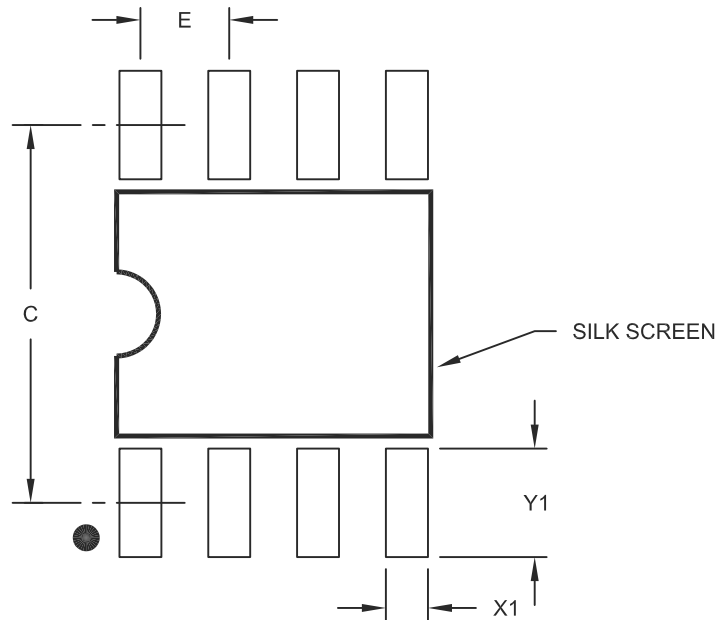
BSC: Basic Dimension. Theoretically exact value shown without tolerances.

REF: Reference Dimension, usually without tolerance, for information purposes only.

Microchip Technology Drawing No. C04-057C Sheet 2 of 2

## 8-Lead Plastic Small Outline (SN) – Narrow, 3.90 mm Body [SOIC]

**Note:** For the most current package drawings, please see the Microchip Packaging Specification located at <http://www.microchip.com/packaging>



RECOMMENDED LAND PATTERN

| Dimension Limits        | Units | MILLIMETERS |      |      |
|-------------------------|-------|-------------|------|------|
|                         |       | MIN         | NOM  | MAX  |
| Contact Pitch           | E     | 1.27 BSC    |      |      |
| Contact Pad Spacing     | C     |             | 5.40 |      |
| Contact Pad Width (X8)  | X1    |             |      | 0.60 |
| Contact Pad Length (X8) | Y1    |             |      | 1.55 |

Notes:

1. Dimensioning and tolerancing per ASME Y14.5M

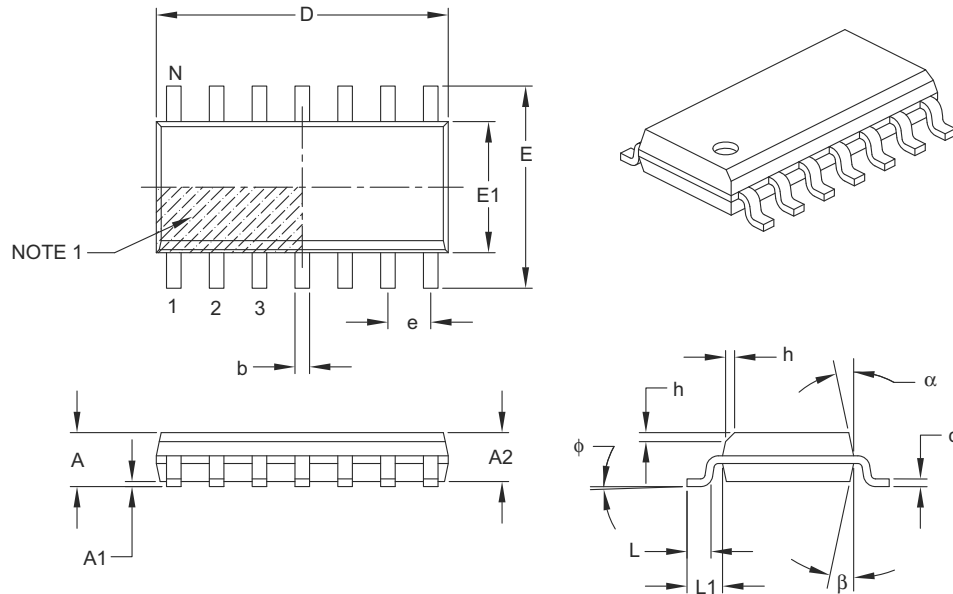
BSC: Basic Dimension. Theoretically exact value shown without tolerances.

Microchip Technology Drawing No. C04-2057A

# MCP6566/6R/6U/7/9

## 14-Lead Plastic Small Outline (SL) – Narrow, 3.90 mm Body [SOIC]

**Note:** For the most current package drawings, please see the Microchip Packaging Specification located at <http://www.microchip.com/packageing>



| Dimension Limits         | Units    | MILLIMETERS |     |      |
|--------------------------|----------|-------------|-----|------|
|                          |          | MIN         | NOM | MAX  |
| Number of Pins           | N        | 14          |     |      |
| Pitch                    | e        | 1.27 BSC    |     |      |
| Overall Height           | A        | –           | –   | 1.75 |
| Molded Package Thickness | A2       | 1.25        | –   | –    |
| Standoff §               | A1       | 0.10        | –   | 0.25 |
| Overall Width            | E        | 6.00 BSC    |     |      |
| Molded Package Width     | E1       | 3.90 BSC    |     |      |
| Overall Length           | D        | 8.65 BSC    |     |      |
| Chamfer (optional)       | h        | 0.25        | –   | 0.50 |
| Foot Length              | L        | 0.40        | –   | 1.27 |
| Footprint                | L1       | 1.04 REF    |     |      |
| Foot Angle               | $\phi$   | 0°          | –   | 8°   |
| Lead Thickness           | c        | 0.17        | –   | 0.25 |
| Lead Width               | b        | 0.31        | –   | 0.51 |
| Mold Draft Angle Top     | $\alpha$ | 5°          | –   | 15°  |
| Mold Draft Angle Bottom  | $\beta$  | 5°          | –   | 15°  |

**Notes:**

- Pin 1 visual index feature may vary, but must be located within the hatched area.
- § Significant Characteristic.
- Dimensions D and E1 do not include mold flash or protrusions. Mold flash or protrusions shall not exceed 0.15 mm per side.
- Dimensioning and tolerancing per ASME Y14.5M.

BSC: Basic Dimension. Theoretically exact value shown without tolerances.

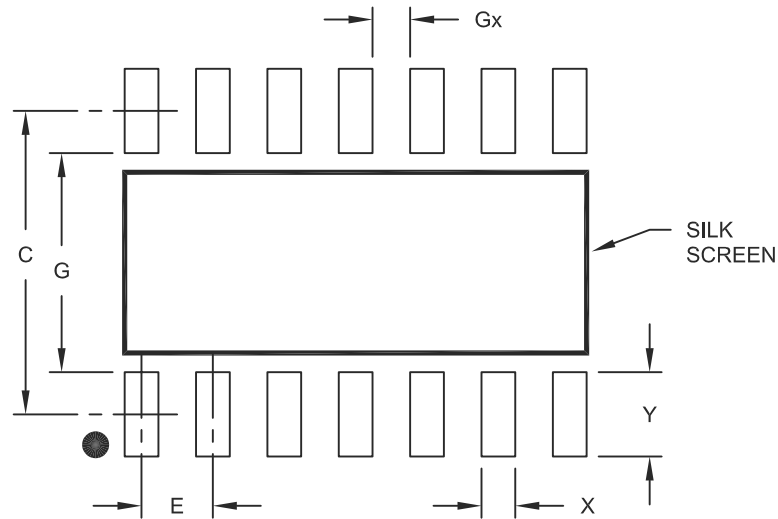
REF: Reference Dimension, usually without tolerance, for information purposes only.

Microchip Technology Drawing C04-065B

# MCP6566/6R/6U/7/9

14-Lead Plastic Small Outline (SL) - Narrow, 3.90 mm Body [SOIC]

**Note:** For the most current package drawings, please see the Microchip Packaging Specification located at <http://www.microchip.com/packaging>



RECOMMENDED LAND PATTERN

| Dimension Limits      | Units | MILLIMETERS |      |      |
|-----------------------|-------|-------------|------|------|
|                       |       | MIN         | NOM  | MAX  |
| Contact Pitch         | E     | 1.27 BSC    |      |      |
| Contact Pad Spacing   | C     |             | 5.40 |      |
| Contact Pad Width     | X     |             |      | 0.60 |
| Contact Pad Length    | Y     |             |      | 1.50 |
| Distance Between Pads | Gx    | 0.67        |      |      |
| Distance Between Pads | G     | 3.90        |      |      |

**Notes:**

1. Dimensioning and tolerancing per ASME Y14.5M

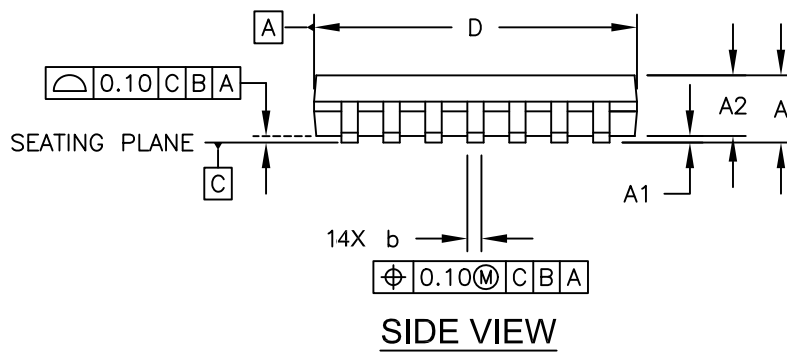
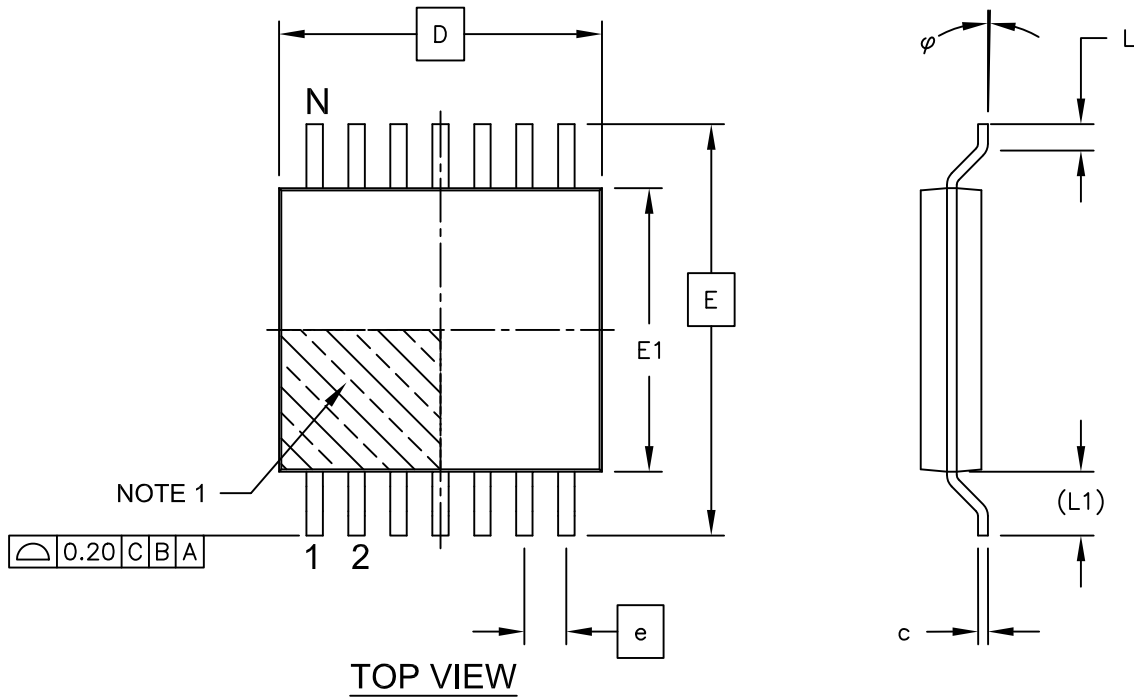
BSC: Basic Dimension. Theoretically exact value shown without tolerances.

Microchip Technology Drawing No. C04-2065A

# MCP6566/6R/6U/7/9

## 14-Lead Plastic Thin Shrink Small Outline (ST) - 4.4 mm Body [TSSOP]

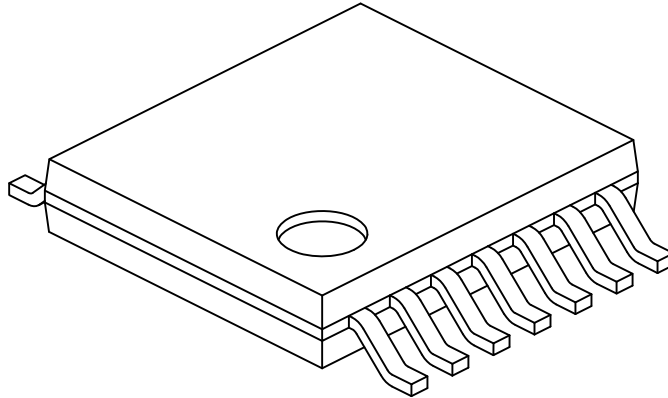
**Note:** For the most current package drawings, please see the Microchip Packaging Specification located at <http://www.microchip.com/packaging>



Microchip Technology Drawing C04-087C Sheet 1 of 2

## 14-Lead Plastic Thin Shrink Small Outline (ST) - 4.4 mm Body [TSSOP]

**Note:** For the most current package drawings, please see the Microchip Packaging Specification located at <http://www.microchip.com/packaging>



| Dimension Limits         | Units     | MILLIMETERS |      |      |
|--------------------------|-----------|-------------|------|------|
|                          |           | MIN         | NOM  | MAX  |
| Number of Pins           | N         | 14          |      |      |
| Pitch                    | e         | 0.65 BSC    |      |      |
| Overall Height           | A         | -           | -    | 1.20 |
| Molded Package Thickness | A2        | 0.80        | 1.00 | 1.05 |
| Standoff                 | A1        | 0.05        | -    | 0.15 |
| Overall Width            | E         | 6.40 BSC    |      |      |
| Molded Package Width     | E1        | 4.30        | 4.40 | 4.50 |
| Molded Package Length    | D         | 4.90        | 5.00 | 5.10 |
| Foot Length              | L         | 0.45        | 0.60 | 0.75 |
| Footprint                | (L1)      | 1.00 REF    |      |      |
| Foot Angle               | $\varphi$ | 0°          | -    | 8°   |
| Lead Thickness           | c         | 0.09        | -    | 0.20 |
| Lead Width               | b         | 0.19        | -    | 0.30 |

**Notes:**

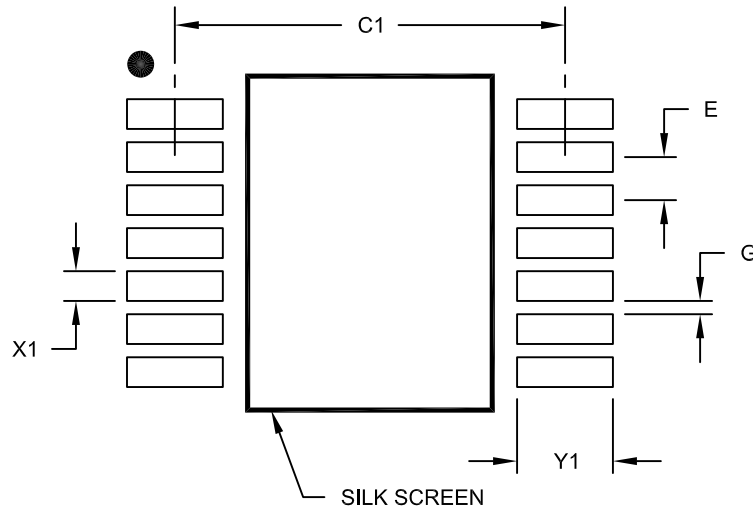
- Pin 1 visual index feature may vary, but must be located within the hatched area.
- Dimensions D and E1 do not include mold flash or protrusions. Mold flash or protrusions shall not exceed 0.15mm per side.
- Dimensioning and tolerancing per ASME Y14.5M
  - BSC: Basic Dimension. Theoretically exact value shown without tolerances.
  - REF: Reference Dimension, usually without tolerance, for information purposes only.

Microchip Technology Drawing No. C04-087C Sheet 2 of 2

# MCP6566/6R/6U/7/9

## 14-Lead Plastic Thin Shrink Small Outline (ST) - 4.4 mm Body [TSSOP]

**Note:** For the most current package drawings, please see the Microchip Packaging Specification located at <http://www.microchip.com/packaging>



RECOMMENDED LAND PATTERN

| Dimension Limits         | Units | MILLIMETERS |          |      |
|--------------------------|-------|-------------|----------|------|
|                          |       | MIN         | NOM      | MAX  |
| Contact Pitch            | E     |             | 0.65 BSC |      |
| Contact Pad Spacing      | C1    |             | 5.90     |      |
| Contact Pad Width (X14)  | X1    |             |          | 0.45 |
| Contact Pad Length (X14) | Y1    |             |          | 1.45 |
| Distance Between Pads    | G     | 0.20        |          |      |

**Notes:**

1. Dimensioning and tolerancing per ASME Y14.5M

BSC: Basic Dimension. Theoretically exact value shown without tolerances.

Microchip Technology Drawing No. C04-2087A



## APPENDIX A: REVISION HISTORY

### Revision C (February 2011)

The following is the list of modifications:

1. Replaced the MCP5468 package name with the correct MCP6567 package name on page 1 and in [Table 3-1](#).

### Revision B (August 2009)

The following is the list of modifications:

1. Added MCP6566U throughout the document.
2. Updated package outline drawings.

### Revision A (March 2009)

- Original Release of this Document.

# MCP6566/6R/6U/7/9

---

NOTES:

## PRODUCT IDENTIFICATION SYSTEM

To order or obtain information, e.g., on pricing or delivery, refer to the factory or the listed sales office.

| <u>PART NO.</u>           | -               | <u>X</u>                                                 | <u>/XX</u>                                                                                                                                                                                                                                                                                                                               |
|---------------------------|-----------------|----------------------------------------------------------|------------------------------------------------------------------------------------------------------------------------------------------------------------------------------------------------------------------------------------------------------------------------------------------------------------------------------------------|
| Device                    |                 | Temperature Range                                        | Package                                                                                                                                                                                                                                                                                                                                  |
| <b>Device:</b>            |                 |                                                          | MCP6566T: Single Comparator (Tape and Reel) (SC70, SOT-23)<br>MCP6566RT: Single Comparator (Tape and Reel) (SOT-23 only)<br>MCP6566UT: Single Comparator (Tape and Reel) (SOT-23 only)<br>MCP6567: Dual Comparator<br>MCP6567T: Dual Comparator (Tape and Reel)<br>MCP6569: Quad Comparator<br>MCP6569T: Quad Comparator (Tape and Reel) |
| <b>Temperature Range:</b> |                 | E = -40°C to +125°C                                      |                                                                                                                                                                                                                                                                                                                                          |
| <b>Package:</b>           |                 |                                                          | LT = Plastic Small Outline Transistor (SC70), 5-lead<br>OT = Plastic Small Outline Transistor (SOT-23), 5-lead<br>MS = Plastic Micro Small Outline Transistor, 8-lead<br>SN = Plastic Small Outline Transistor, 8-lead<br>ST = Plastic Thin Shrink Small Outline Transistor, 14-lead<br>SL = Plastic Small Outline Transistor, 14-lead   |
| <b>Examples:</b>          |                 |                                                          |                                                                                                                                                                                                                                                                                                                                          |
| a)                        | MCP6566T-E/LT:  | Tape and Reel, Extended Temperature, 5LD SC70 package.   |                                                                                                                                                                                                                                                                                                                                          |
| b)                        | MCP6566T-E/OT:  | Tape and Reel, Extended Temperature, 5LD SOT-23 package. |                                                                                                                                                                                                                                                                                                                                          |
| a)                        | MCP6566RT-E/OT: | Tape and Reel, Extended Temperature, 5LD SOT-23 package. |                                                                                                                                                                                                                                                                                                                                          |
| a)                        | MCP6566UT-E/OT: | Tape and Reel, Extended Temperature, 5LD SOT-23 package. |                                                                                                                                                                                                                                                                                                                                          |
| a)                        | MCP6567-E/MS:   | Extended Temperature 8LD MSOP package.                   |                                                                                                                                                                                                                                                                                                                                          |
| b)                        | MCP6567-E/SN:   | Extended Temperature 8LD SOIC package.                   |                                                                                                                                                                                                                                                                                                                                          |
| a)                        | MCP6569T-E/SL:  | Tape and Reel, Extended Temperature 14LD SOIC package.   |                                                                                                                                                                                                                                                                                                                                          |
| b)                        | MCP6569T-E/ST:  | Tape and Reel, Extended Temperature 14LD TSSOP package.  |                                                                                                                                                                                                                                                                                                                                          |

# MCP6566/6R/6U/7/9

---

NOTES:

---

**Note the following details of the code protection feature on Microchip devices:**

- Microchip products meet the specification contained in their particular Microchip Data Sheet.
- Microchip believes that its family of products is one of the most secure families of its kind on the market today, when used in the intended manner and under normal conditions.
- There are dishonest and possibly illegal methods used to breach the code protection feature. All of these methods, to our knowledge, require using the Microchip products in a manner outside the operating specifications contained in Microchip's Data Sheets. Most likely, the person doing so is engaged in theft of intellectual property.
- Microchip is willing to work with the customer who is concerned about the integrity of their code.
- Neither Microchip nor any other semiconductor manufacturer can guarantee the security of their code. Code protection does not mean that we are guaranteeing the product as “unbreakable.”

Code protection is constantly evolving. We at Microchip are committed to continuously improving the code protection features of our products. Attempts to break Microchip's code protection feature may be a violation of the Digital Millennium Copyright Act. If such acts allow unauthorized access to your software or other copyrighted work, you may have a right to sue for relief under that Act.

---

Information contained in this publication regarding device applications and the like is provided only for your convenience and may be superseded by updates. It is your responsibility to ensure that your application meets with your specifications. MICROCHIP MAKES NO REPRESENTATIONS OR WARRANTIES OF ANY KIND WHETHER EXPRESS OR IMPLIED, WRITTEN OR ORAL, STATUTORY OR OTHERWISE, RELATED TO THE INFORMATION, INCLUDING BUT NOT LIMITED TO ITS CONDITION, QUALITY, PERFORMANCE, MERCHANTABILITY OR FITNESS FOR PURPOSE. Microchip disclaims all liability arising from this information and its use. Use of Microchip devices in life support and/or safety applications is entirely at the buyer's risk, and the buyer agrees to defend, indemnify and hold harmless Microchip from any and all damages, claims, suits, or expenses resulting from such use. No licenses are conveyed, implicitly or otherwise, under any Microchip intellectual property rights.

**Trademarks**

The Microchip name and logo, the Microchip logo, dsPIC, KEELOQ, KEELOQ logo, MPLAB, PIC, PICmicro, PICSTART, PIC<sup>32</sup> logo, rPIC and UNI/O are registered trademarks of Microchip Technology Incorporated in the U.S.A. and other countries.


FilterLab, Hampshire, HI-TECH C, Linear Active Thermistor, MXDEV, MXLAB, SEEVAL and The Embedded Control Solutions Company are registered trademarks of Microchip Technology Incorporated in the U.S.A.

Analog-for-the-Digital Age, Application Maestro, CodeGuard, dsPICDEM, dsPICDEM.net, dsPICworks, dsSPEAK, ECAN, ECONOMONITOR, FanSense, HI-TIDE, In-Circuit Serial Programming, ICSP, Mindi, MiWi, MPASM, MPLAB Certified logo, MPLIB, MPLINK, mTouch, Omniscient Code Generation, PICC, PICC-18, PICDEM, PICDEM.net, PICkit, PICTail, REAL ICE, rLAB, Select Mode, Total Endurance, TSHARC, UniWinDriver, WiperLock and ZENA are trademarks of Microchip Technology Incorporated in the U.S.A. and other countries.

SQTP is a service mark of Microchip Technology Incorporated in the U.S.A.

All other trademarks mentioned herein are property of their respective companies.

© 2011, Microchip Technology Incorporated, Printed in the U.S.A., All Rights Reserved.

 Printed on recycled paper.

ISBN: 978-1-60932-892-4

*Microchip received ISO/TS-16949:2002 certification for its worldwide headquarters, design and wafer fabrication facilities in Chandler and Tempe, Arizona; Gresham, Oregon and design centers in California and India. The Company's quality system processes and procedures are for its PIC® MCUs and dsPIC® DSCs, KEELOQ® code hopping devices, Serial EEPROMs, microperipherals, nonvolatile memory and analog products. In addition, Microchip's quality system for the design and manufacture of development systems is ISO 9001:2000 certified.*

**QUALITY MANAGEMENT SYSTEM  
CERTIFIED BY DNV  
== ISO/TS 16949:2002 ==**



# MICROCHIP

## Worldwide Sales and Service

### AMERICAS

**Corporate Office**  
2355 West Chandler Blvd.  
Chandler, AZ 85224-6199  
Tel: 480-792-7200  
Fax: 480-792-7277  
Technical Support:  
<http://support.microchip.com>  
Web Address:  
[www.microchip.com](http://www.microchip.com)

**Atlanta**  
Duluth, GA  
Tel: 678-957-9614  
Fax: 678-957-1455

**Boston**  
Westborough, MA  
Tel: 774-760-0087  
Fax: 774-760-0088

**Chicago**  
Itasca, IL  
Tel: 630-285-0071  
Fax: 630-285-0075

**Cleveland**  
Independence, OH  
Tel: 216-447-0464  
Fax: 216-447-0643

**Dallas**  
Addison, TX  
Tel: 972-818-7423  
Fax: 972-818-2924

**Detroit**  
Farmington Hills, MI  
Tel: 248-538-2250  
Fax: 248-538-2260

**Kokomo**  
Kokomo, IN  
Tel: 765-864-8360  
Fax: 765-864-8387

**Los Angeles**  
Mission Viejo, CA  
Tel: 949-462-9523  
Fax: 949-462-9608

**Santa Clara**  
Santa Clara, CA  
Tel: 408-961-6444  
Fax: 408-961-6445

**Toronto**  
Mississauga, Ontario,  
Canada  
Tel: 905-673-0699  
Fax: 905-673-6509

### ASIA/PACIFIC

**Asia Pacific Office**  
Suites 3707-14, 37th Floor  
Tower 6, The Gateway  
Harbour City, Kowloon  
Hong Kong  
Tel: 852-2401-1200  
Fax: 852-2401-3431

**Australia - Sydney**  
Tel: 61-2-9868-6733  
Fax: 61-2-9868-6755

**China - Beijing**  
Tel: 86-10-8528-2100  
Fax: 86-10-8528-2104

**China - Chengdu**  
Tel: 86-28-8665-5511  
Fax: 86-28-8665-7889

**China - Chongqing**  
Tel: 86-23-8980-9588  
Fax: 86-23-8980-9500

**China - Hong Kong SAR**  
Tel: 852-2401-1200  
Fax: 852-2401-3431

**China - Nanjing**  
Tel: 86-25-8473-2460  
Fax: 86-25-8473-2470

**China - Qingdao**  
Tel: 86-532-8502-7355  
Fax: 86-532-8502-7205

**China - Shanghai**  
Tel: 86-21-5407-5533  
Fax: 86-21-5407-5066

**China - Shenyang**  
Tel: 86-24-2334-2829  
Fax: 86-24-2334-2393

**China - Shenzhen**  
Tel: 86-755-8203-2660  
Fax: 86-755-8203-1760

**China - Wuhan**  
Tel: 86-27-5980-5300  
Fax: 86-27-5980-5118

**China - Xian**  
Tel: 86-29-8833-7252  
Fax: 86-29-8833-7256

**China - Xiamen**  
Tel: 86-592-2388138  
Fax: 86-592-2388130

**China - Zhuhai**  
Tel: 86-756-3210040  
Fax: 86-756-3210049

### ASIA/PACIFIC

**India - Bangalore**  
Tel: 91-80-3090-4444  
Fax: 91-80-3090-4123

**India - New Delhi**  
Tel: 91-11-4160-8631  
Fax: 91-11-4160-8632

**India - Pune**  
Tel: 91-20-2566-1512  
Fax: 91-20-2566-1513

**Japan - Yokohama**  
Tel: 81-45-471- 6166  
Fax: 81-45-471-6122

**Korea - Daegu**  
Tel: 82-53-744-4301  
Fax: 82-53-744-4302

**Korea - Seoul**  
Tel: 82-2-554-7200  
Fax: 82-2-558-5932 or  
82-2-558-5934

**Malaysia - Kuala Lumpur**  
Tel: 60-3-6201-9857  
Fax: 60-3-6201-9859

**Malaysia - Penang**  
Tel: 60-4-227-8870  
Fax: 60-4-227-4068

**Philippines - Manila**  
Tel: 63-2-634-9065  
Fax: 63-2-634-9069

**Singapore**  
Tel: 65-6334-8870  
Fax: 65-6334-8850

**Taiwan - Hsin Chu**  
Tel: 886-3-6578-300  
Fax: 886-3-6578-370

**Taiwan - Kaohsiung**  
Tel: 886-7-213-7830  
Fax: 886-7-330-9305

**Taiwan - Taipei**  
Tel: 886-2-2500-6610  
Fax: 886-2-2508-0102

**Thailand - Bangkok**  
Tel: 66-2-694-1351  
Fax: 66-2-694-1350

### EUROPE

**Austria - Wels**  
Tel: 43-7242-2244-39  
Fax: 43-7242-2244-393

**Denmark - Copenhagen**  
Tel: 45-4450-2828  
Fax: 45-4485-2829

**France - Paris**  
Tel: 33-1-69-53-63-20  
Fax: 33-1-69-30-90-79

**Germany - Munich**  
Tel: 49-89-627-144-0  
Fax: 49-89-627-144-44

**Italy - Milan**  
Tel: 39-0331-742611  
Fax: 39-0331-466781

**Netherlands - Drunen**  
Tel: 31-416-690399  
Fax: 31-416-690340

**Spain - Madrid**  
Tel: 34-91-708-08-90  
Fax: 34-91-708-08-91

**UK - Wokingham**  
Tel: 44-118-921-5869  
Fax: 44-118-921-5820

08/04/10