

Schottky Barrier Diode

BAT42W-BAT43W

FEATURES

- Low forward voltage.
- Fast switching time.
- Surface mount package ideally suited for automatic insertion.

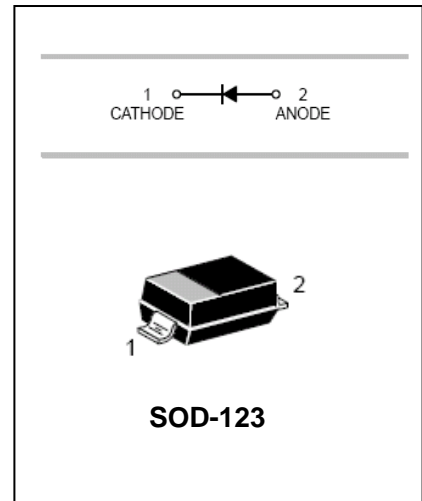

APPLICATIONS

- Schottky barrier detector and switching diodes.

ORDERING INFORMATION

Type No.	Marking	Package Code
BAT42W	S7	SOD-123
BAT43W	S8	SOD-123

MAXIMUM RATING @ Ta=25°C unless otherwise specified

Parameter	Symbol	Limits	Unit
Non-Repetitive Peak reverse voltage	V_{RM}	30	V
Working peak	V_{RWM}		
DC Reverse Voltage	V_R		
RMS Reverse Voltage	$V_{R(RMS)}$	21	V
Forward continuous Current	I_F	200	mA
Repetitive peak Forward Current	I_{FRM}	500	mA
Forward Surge Current	I_{FSM}	4.0	A
Power Dissipation	P_d	200	mW
Thermal resistance, junction to ambient air	$R_{\theta JA}$	625	°C/W
Junction temperature	T_j	125	°C
Storage temperature range	T_{stg}	-55-125	°C

Schottky Barrier Diode

BAT42W-BAT43W

ELECTRICAL CHARACTERISTICS @ Ta=25°C unless otherwise specified

Parameter	Symbol	Conditions	Min.	Typ.	Max.	Unit
Reverse Breakdown Voltage	$V_{(BR)R}$	$I_R=100\mu A$	30			V
Forward voltage	ALL types BAT42W BAT42W BAT43W BAT43W	$I_F=200mA$			1.0	V
		$I_F=10mA$			0.4	V
		$I_F=50mA$			0.65	V
		$I_F=2mA$	0.26		0.33	V
		$I_F=15mA$			0.45	V
Reverse current	I_R	$V_R=25V$			0.5	μA
Reverse recovery time	t_{rr}	$I_F=I_R=10mA$ $I_{tr}=0.1*I_R$ $R_L=100\Omega$			5.0	ns
Capacitance between terminals	C_T	$V_R=1V, f=1MHz$			10	pF

PACKAGE OUTLINE

Plastic surface mounted package

SOD-123

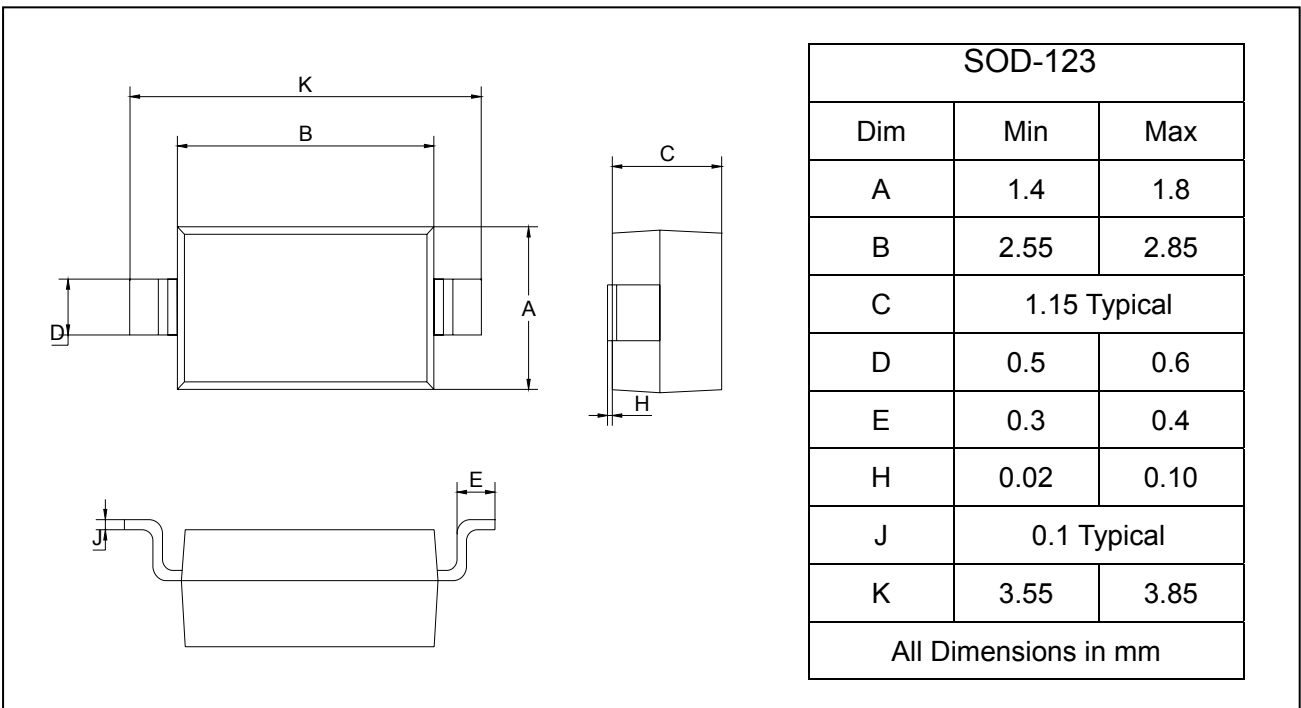

Schottky Barrier Diode

BAT42W-BAT43W

SOLDERING FOOTPRINT

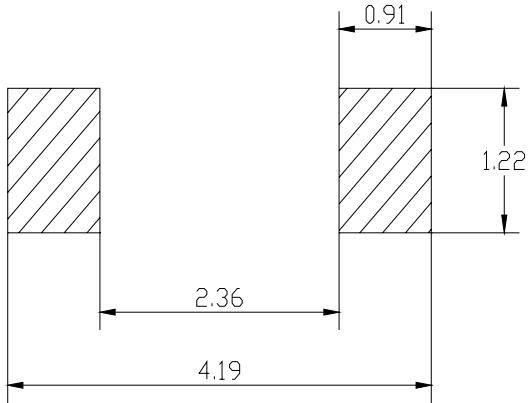

Unit : mm

PACKAGE INFORMATION

Device	Package	Shipping
BAT42W/43W	SOD-123	3000/Tape&Reel