

## Schottky Barrier Diode

## BAT42WS/BAT43WS

### FEATURES

- Low Forward drop voltage.
- Fast switching.
- Ultra-small surface mount package.
- Available in lead free version.

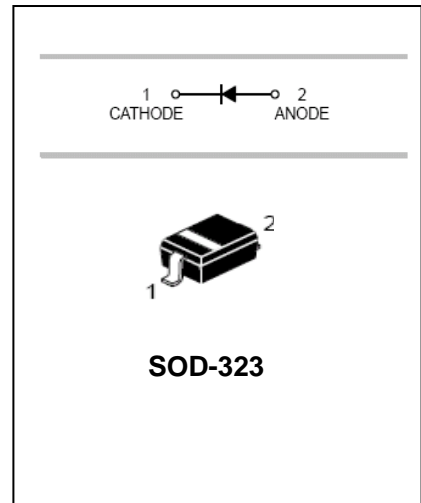

### APPLICATIONS

- Schottky barrier detector and switching diodes.

### ORDERING INFORMATION

Type No.	Marking	Package Code
BAT42WS	S7	SOD-323
BAT43WS	S8	SOD-323

### MAXIMUM RATING @ Ta=25°C unless otherwise specified

Parameter	Symbol	Limits	Unit
Peak Repetitive Peak reverse voltage	$V_{RRM}$	30	V
Working Peak	$V_{RWM}$		
DC Reverse Voltage	$V_R$		
RMS reverse voltage	$V_{R(RMS)}$	21	V
Forward continuous Current	$I_{FM}$	200	mA
Repetitive peak Forward Current@t<1.0s	$I_{FRM}$	500	mA
Peak Forward Surge Current@<10ms	$I_{FSM}$	4.0	A
Power Dissipation	$P_d$	200	mW
Thermal resistance, junction to ambient	$R_{\theta JA}$	625	°C/W
Junction temperature	$T_j$	125	°C
Storage temperature range	$T_{stg}$	-55-125	°C

## Schottky Barrier Diode

## BAT42WS/BAT43WS

### ELECTRICAL CHARACTERISTICS @ Ta=25°C unless otherwise specified

Parameter	Symbol	Conditions	Min.	Typ.	Max.	Unit
Reverse Breakdown Voltage	$V_{(BR)R}$	$I_R=100\mu A$	30			V
Forward voltage	$V_F$	All types $I_F=200mA$			1.0	V
		BAT42W $I_F=10mA$			0.4	V
		BAT42W $I_F=50mA$			0.65	V
		BAT43W $I_F=2mA$			0.33	V
		BAT43W $I_F=15mA$			0.45	V
Reverse current	$I_R$	$V_R=25v$			0.5	$\mu A$
Reverse recovery time	$t_{rr}$	$I_F=10mA, I_R=10mA$ $R_L=100\Omega$			5.0	ns
Capacitance between terminals	$C_T$	$V_R=1.0V, f=1MHz$			10	pF

### TYPICAL CHARACTERISTICS @ Ta=25°C unless otherwise specified

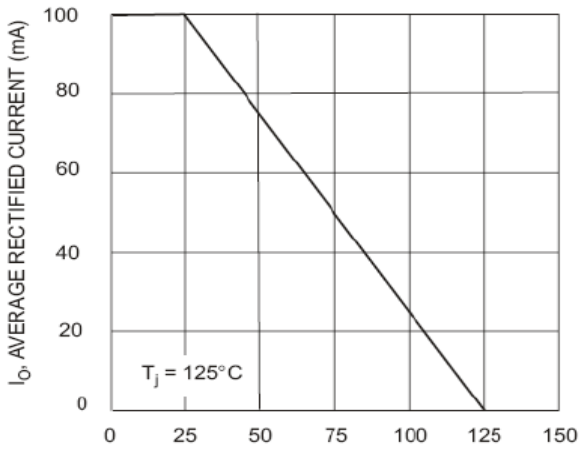

Fig. 1 Forward Current Derating Curve

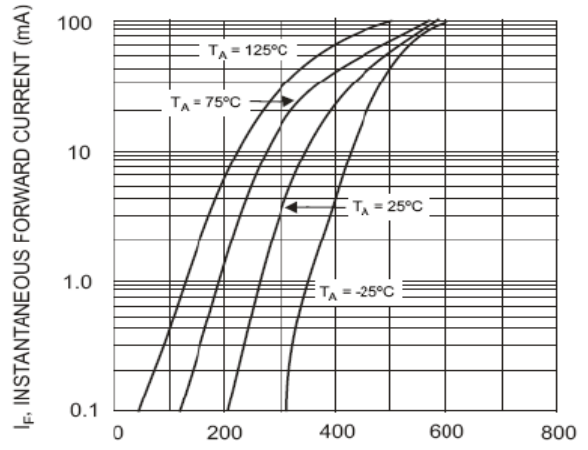

Fig. 2 Typical Forward Characteristics

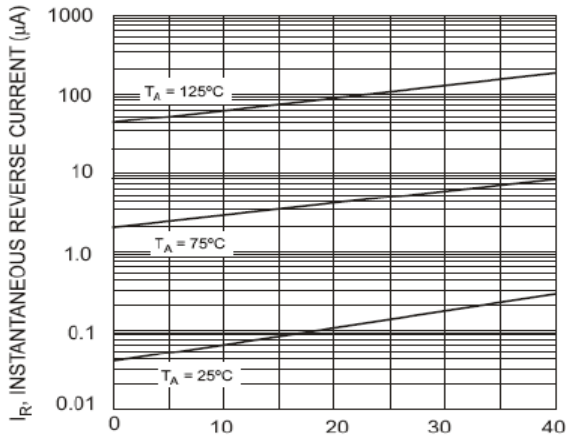

Fig. 3 Typical Reverse Characteristics

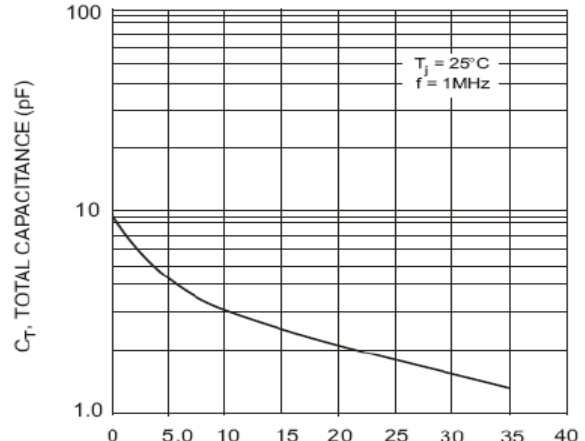

Fig. 4 Total Capacitance vs. Reverse Voltage

## Schottky Barrier Diode

## BAT42WS/BAT43WS

### PACKAGE OUTLINE

Plastic surface mounted package

SOD-323

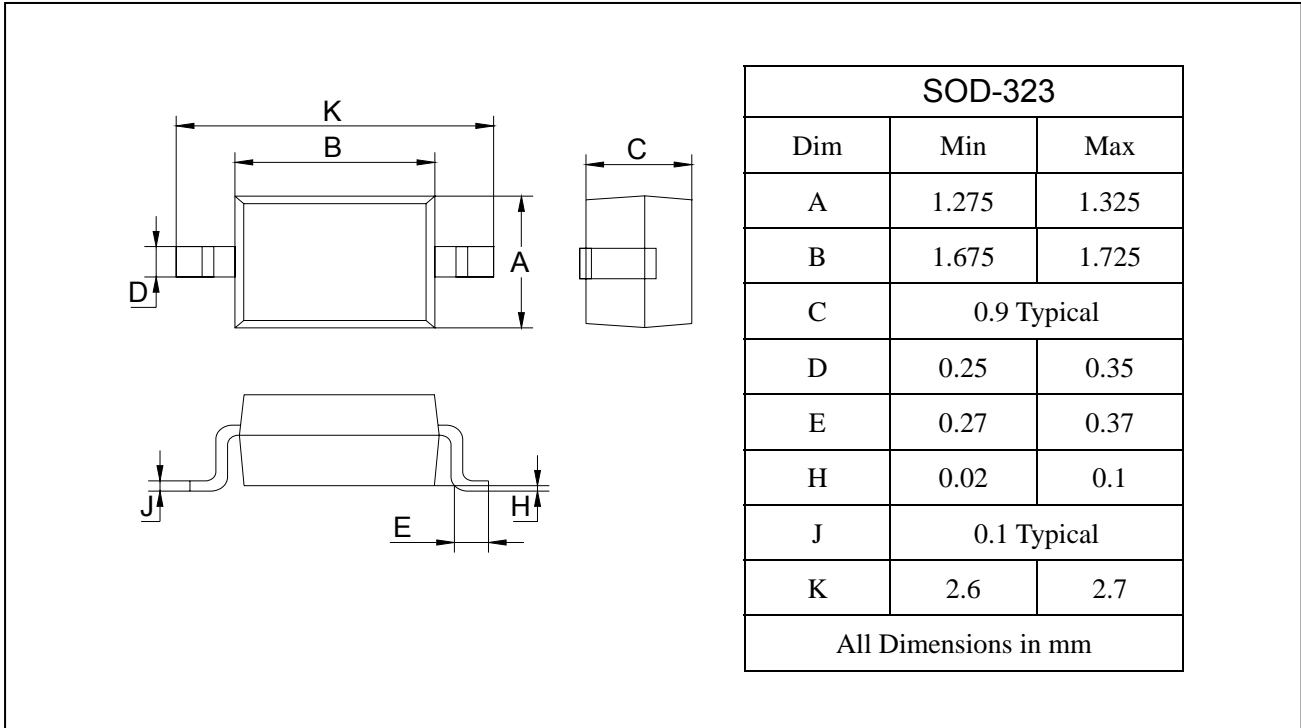

### SOLDERING FOOTPRINT

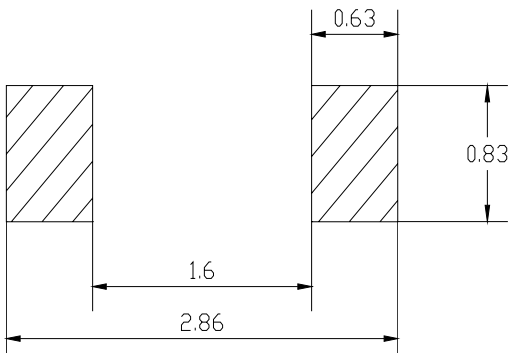

Unit : mm

### PACKAGE INFORMATION

Device	Package	Shipping
BAT42WS/BAT43WS	SOD-323	3000/Tape&Reel