

# Astrodyne

PowerBlock Micro-Miniature Modular Switching Power Supplies

**PWB series**



2"L x 1"W x 0.6"H

- Single 5 Watt Outputs
- 3.3VDC to 24VDC
- Universal 90 to 264VAC Input
- 3,000VAC Input to Output Isolation
- 0 to +50°C Operation
- High Efficiency



Model Number	Output Voltage	Output Amps	Output Watts	Size (inches)
PWB-5000	3.3 VDC	1.25	4W	1 x 2 x 0.6
PWB-5001	5 VDC	1	5W	1 x 2 x 0.6
PWB-5002	12 VDC	0.42	5W	1 x 2 x 0.6
PWB-5003	15 VDC	0.33	5W	1 x 2 x 0.6
PWB-5005	24 VDC	0.23	5W	1 x 2 x 0.6

**INPUT SPECIFICATIONS**

Input Voltage, Nominal	90-264VAC
	Nominal: 100-240VAC
Input Frequency	47-63 Hz, 50-60Hz Nom.
Inrush Current	20A @ 115VAC, typ
	40A @ 230VAC, typ
Leakage Current	<3.5mA @ 264VAC, 50Hz

**OUTPUT SPECIFICATIONS**

Output Voltage/Current	See Specific Model
Initial Accuracy	+/-1%, typ
Load Regulation	3.3V & 5V: +/-1%, typ
20%-FL	12V, 15V, & 24V: +/-0.5%, typ
Line Regulation	3.3V & 5V: +/-1%, typ
	12V, 15V, & 24V: +/-0.5%, typ
Temperature Coefficient	+/-0.03%/°C
Ripple/Noise(20Mhz BW)	200-250mV Pk-Pk, max.
Overvoltage Protection	120-150%, Auto-recovery *
Hold Up Time	10ms, typ. @ nom. input
Short Circuit Protection	Auto-recovery *
Over Current Protection	Auto-recovery *

**GENERAL SPECIFICATIONS**

Input-Out Isolation	3000VAC
Operating Frequency	100 Khz, fixed, typ
Efficiency @ nom input	71 - 80%, typ (61% typ for 3.3V)
Safety UL/cUL:	UL60950-1 2nd ed./
	C22.2 60950-1 2nd ed.
UL-EU:	EN60950-1 2nd ed.
CE:	EN60601-1-2
CB:	IEC60950-1 2nd ed.
EMC	EN55011 Class B

**ENVIRONMENTAL SPECIFICATIONS**

Oper. Temperature	0 to +50°C FL
	Derate Linearly to 20%L @ 70°C
Relative Humidity	0-95%, Non-Condensing
Storage Temperature	-25 to +71°C *
MTBF	380,000 Hrs
	MIL-HDBK 217, Parts Count Method,
	25°C, Ground Benign

**PHYSICAL SPECIFICATIONS**

Case Material	Rynite, 94V-0 Rated
Construction	Encapsulated, Soft Pot
Weight	1.5 oz (42g)

All specifications are typical at nominal input, full load, and 25DegC unless otherwise noted

\* These are stress ratings. Exposure of the devices to any of these conditions may adversely affect long term reliability. Proper operation under conditions other than the standard operating conditions is neither warranted nor implied.

### MECHANICAL SPECIFICATIONS

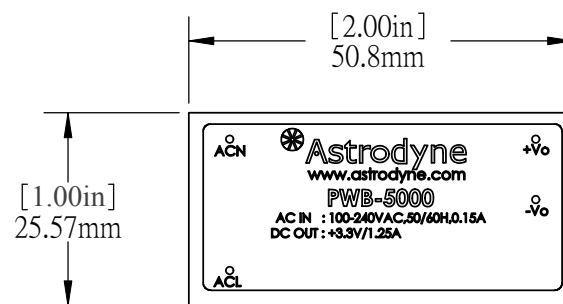
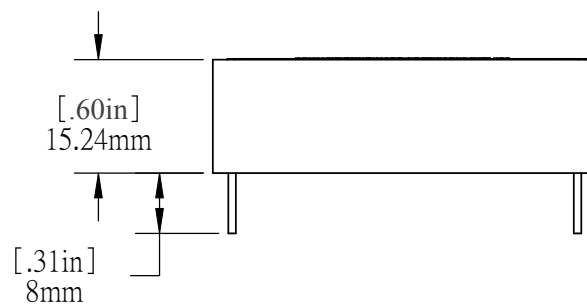
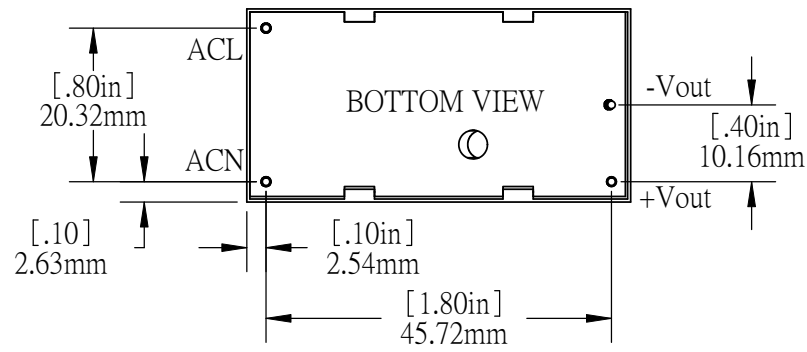

**OUTPUT DERATING CURVE**

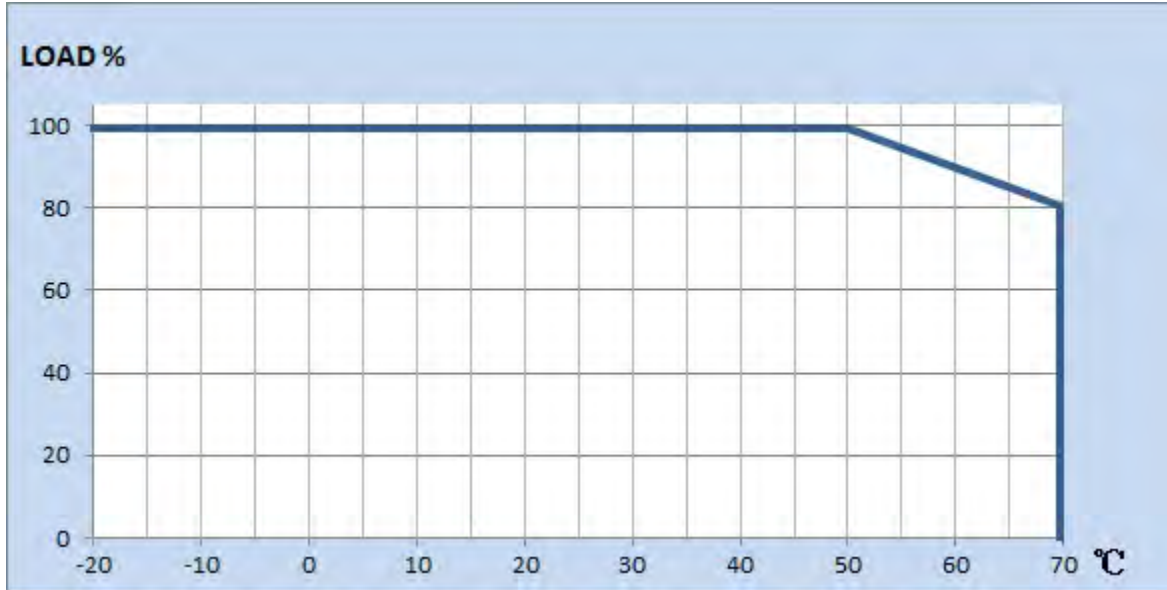

**POWER BLOCK APPLICATION NOTES**

**Output Noise**

The figure below is a sample diagram to reduce Output Ripple and Noise.

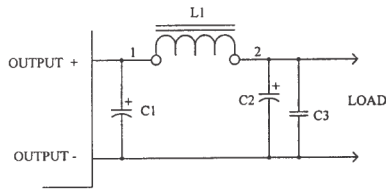

C1 = Electrolytic Capacitor  
 Capacitance = 22uF - 220uF  
 Voltage = Two times rated output voltage

L1 = 3uH - 10uH

C2 = Electrolytic Capacitor  
 Capacitance = 22uF - 47uF  
 Voltage = Two times rated output voltage

C3 = Ceramic Capacitor  
 Capacitance = 0.01uF - 0.1uF  
 Voltage = 50 volt

Notes:

1. The use of C1 alone may reduce noise to desired levels, if not use L1, C2 and C3 in addition to C1.
2. The figure above is a suggested circuit. Only by trying true application can levels be tested.

**EMI**

The figure below is a suggested diagram to reduce Electromagnetic Interference (EMI).

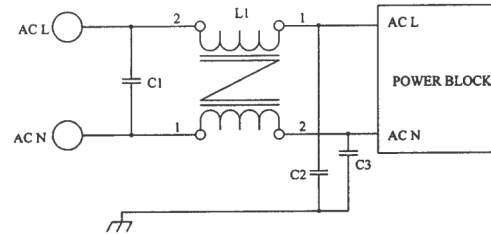

C1 = 0.22uF X Capacitor

L1 = 10mH - 30mH Common Mode, Choke

C2, C3 = 220pF Y Capacitors

Notes:

The diagram above is a recommended circuit, only by trying true application can levels be measured.

**Inrush Current**

If desired, the use of a Choke, NTC or Inrush Current Limiter may be used to reduce the Inrush Current