



# ACE724C

## 18V 2.5A Synchronous PFM/PWM Buck Converter

### Description

The ACE724C is a high efficiency current-mode synchronous, 18V/2.5A buck converter. Its input voltage ranges from 3.5V to 18V and it provides an adjustable regulated output voltage from 0.923V to 15V while delivering up to 2A of output current.

The internal synchronous switches increase efficiency and eliminate the need for an external Schottky diode. The switching frequency is set to 340KHz. And the ACE724C will automatically switch between PFM and PWM mode based on the load current, thus to enhance the converter efficiency at light load.

ACE724C consists of many protection block such as UVLO, input voltage over voltage protection to stand much higher input voltage spike, thermal protection and output short circuit protection.

### Features

- Adjustable Output Voltage,  $V_{fb}=0.923V$
- Maximum output current is 2.5A
- Range of operation input voltage: Max 18V
- UVLO: 3.4V (typ.)
- Withstand input voltage spike >30V
- Standby current: 1mA (typ.)
- Operating current at zero load: 1.2mA (typ.)
- Line regulation: 0.1%/V (typ.)
- Load regulation: 10mV (typ.)
- High efficiency, up to 95%
- Environment Temperature:  $-20^{\circ}C \sim 85^{\circ}C$

### Application

- Set-top-box
- Consumer Electronic Device for automobile
- LCD Monitor and LCD TV
- Portable DVD
- ADSL Modem, WLAN router
- Other 12V or double cell Li-ion battery powered device

### Absolute Maximum Ratings

| Parameter                                     | Symbol        | Value    | Unit          |
|---|---------------|----------|---------------|
| Input voltage                                 |               | 30       | V             |
| Ambien temperature                            | $T_A$         | -20~85   | $^{\circ}C$   |
| Package thermal resistance<br>SOP-8<br>ESOP-8 | $\Theta_{JC}$ | 45<br>10 | $^{\circ}C/W$ |
| Max Operation junction temperature            | $T_j$         | 125      | $^{\circ}C$   |
| ESD (HBM)                                     |               | >2000    | V             |
| Storage temperature range                     | $T_s$         | -40~125  | $^{\circ}C$   |

Note: Exceed these limits to damage to the device. Exposure to absolute maximum rating conditions may affect device reliability.



# ACE724C

## 18V 2.5A Synchronous PFM/PWM Buck Converter

### Packaging Type

SOP-8 / ESOP-8

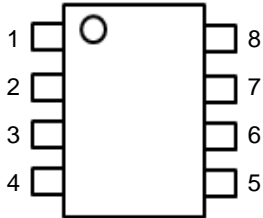

| SOP-8/ESOP-8 | Description | Function   |
|--------------|-------------|--|
| 1            | BST         | High side power transistor gate drive boost input  |
| 2            | VIN         | Power input, the input capacitor should be placed as close to VIN and GND pin as possible  |
| 3            | SW          | Power switching node to connect inductor   |
| 4            | GND         | Ground   |
| 5            | FB          | Feedback input with reference voltage set to 0.923   |
| 6            | COMP        | Compensation node. A serial RC connected to this pin is required to maintain the Buck converter control loop stable                                      |
| 7            | EN          | Enable input. Setting it to high level or connecting to Vin via a resistor may turn on the chip, while setting it to ground level will turn off the chip |
| 8            | SS          | Soft-start node. Connecting a 0.1uF capacitor to ground make the Buck converter output rise smoothly   |

### Ordering information

Selection Guide

ACE724C XX + H

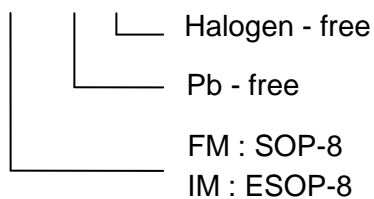



# ACE724C

## 18V 2.5A Synchronous PFM/PWM Buck Converter

### Block Diagram

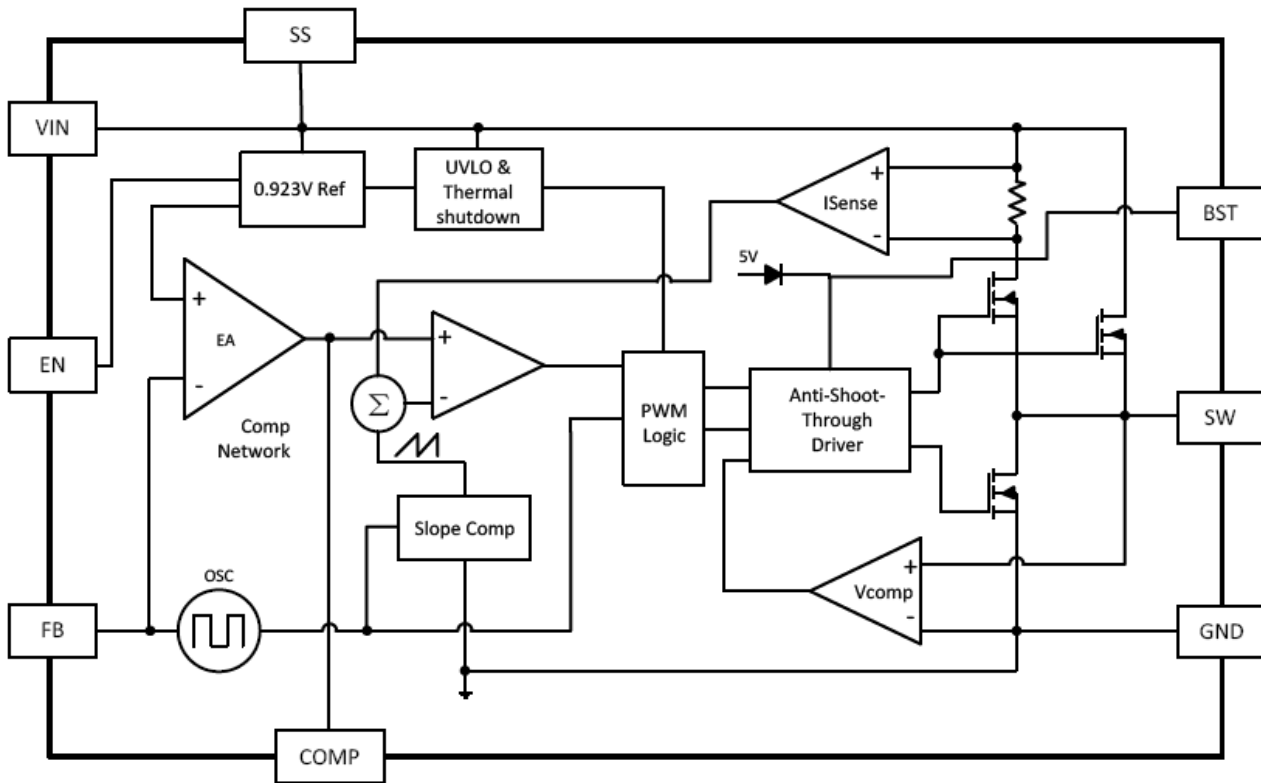

### Recommended Work Conditions

| Item                           | Value   | Unit |
|--------------------------------|---------|------|
| Input voltage range            | Max. 18 | V    |
| Operating junction temperature | -20~125 | °C   |

### PFM at Light Load

Zero Load Operating Current vs. Vin

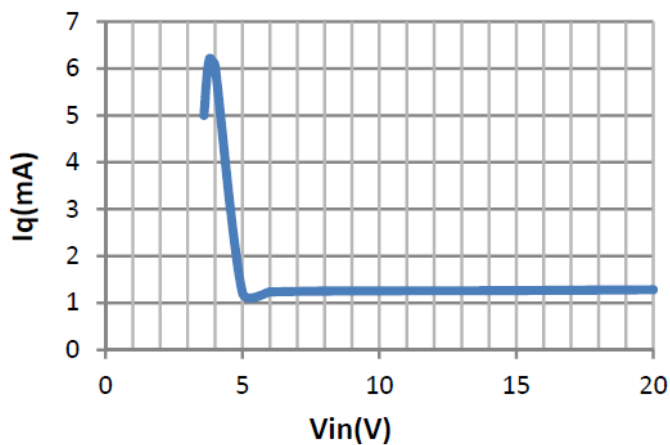



# ACE724C

## 18V 2.5A Synchronous PFM/PWM Buck Converter

### Typical Application

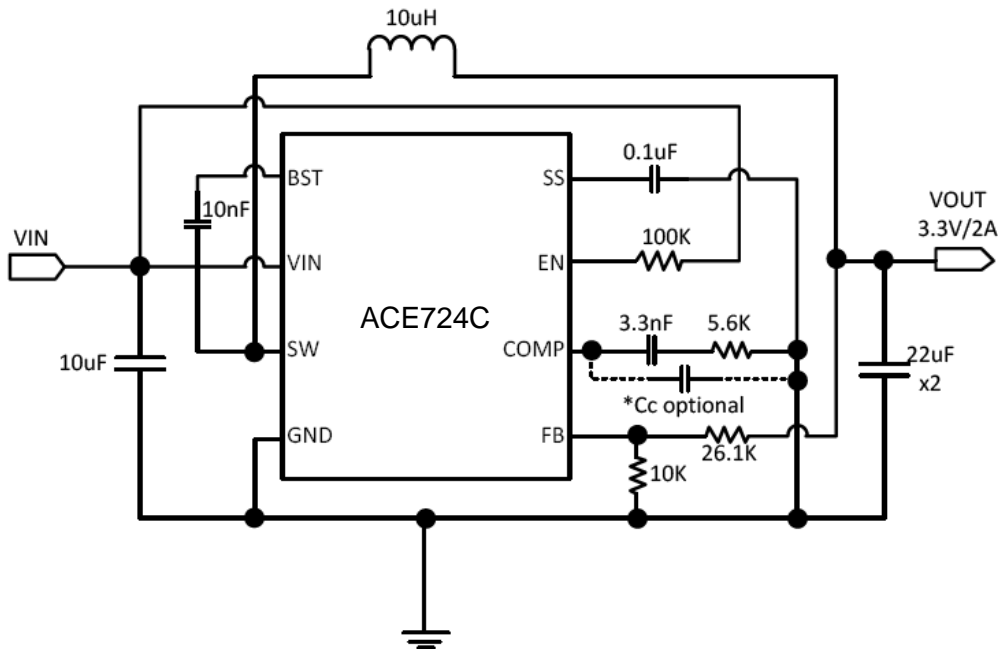

\* When Vin is as low as 5V, Cc is recommended to be 100pf, but not needed when Vin larger than 5V.

### Electrical Characteristics

(Vin=12V, TA=25°C)

| Parameter                  | Symbol             | Test Conditions              | Min  | Typ   | Max   | Unit |
|----------------------------|--------------------|------------------------------|------|-------|-------|------|
| Input voltage range        | VDD                |                              | 3.5  |       | 18    | V    |
| Feedback voltage           | Vref               | Vin=12V, Ven=5V              | 0.90 | 0.923 | 0.946 | V    |
| UVLO Voltage               | V <sub>UVLO</sub>  | Vin H->L, Iout=0.5A          |      | 3.4   |       | V    |
| Feedback leakage current   | I <sub>fb</sub>    |                              |      | 0.1   | 0.4   | uA   |
| Quiescent current          | I <sub>q</sub>     | Active, Vfb=1V, No switching |      | 1.1   | 1.5   | mA   |
|                            |                    | Shutdown, Vin=8V             |      | 6     | 10    | uA   |
| Line regulation            | LnReg              | Vin=5V to 12V                |      | 0.1   |       | %/V  |
| Load regulation            | LdReg              | Iout=0.1 to 2A               |      | 0.02  |       | %/A  |
| Switching                  | F <sub>sw</sub>    | Ven=2V, Vin=12V              |      | 340   |       | KHz  |
| PMOS Rdson                 | R <sub>dsonP</sub> |                              |      | 130   |       | mΩ   |
| NMOS Rdson                 | R <sub>dsonN</sub> |                              |      | 110   |       | mΩ   |
| Peak current limit         | L <sub>limit</sub> |                              |      | 3.8   |       | A    |
| EN high threshold          | V <sub>enh</sub>   |                              | 1    | 1.5   | 2     | V    |
| EN low threshold           | V <sub>enl</sub>   |                              |      |       | 0.5   |      |
| Input over-voltage         | V <sub>ovp</sub>   | Ven=2V                       | 18   |       |       | V    |
| Over temperature proection | TSD                |                              |      | 160   |       | °C   |



# ACE724C

## 18V 2.5A Synchronous PFM/PWM Buck Converter

### Typical performance characteristics

( $V_{in}=12V$ ,  $V_{out}=3.3V$ ,  $L=10\mu H$ ,  $C_{in}=10\mu F$ ,  $C_{out}=22\mu F$ ,  $T_A=25^\circ C$ , unless otherwise stated)

**Efficiency( $V_{out}=3.3V$ )**

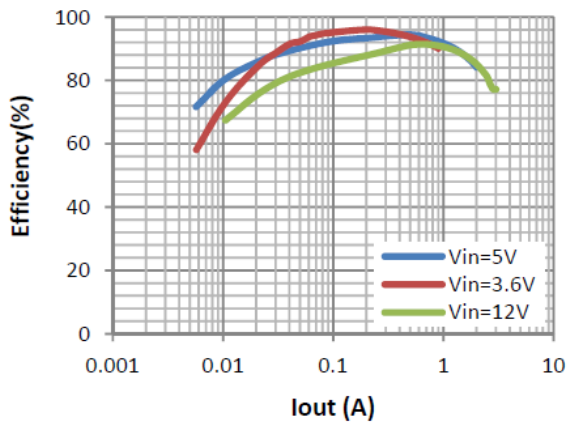

**$V_{out}$  vs.  $I_{out}$**

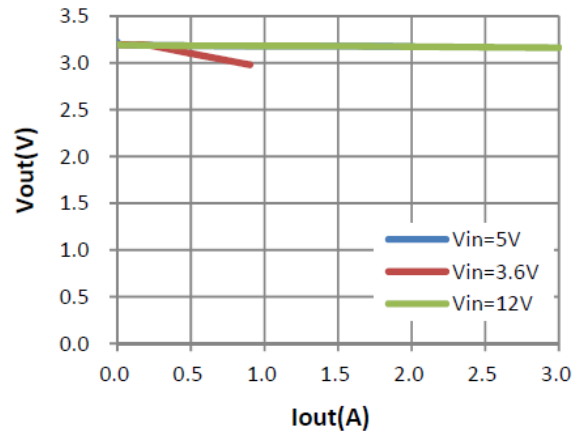

**$V_{out}$  vs.  $I_{out}$**

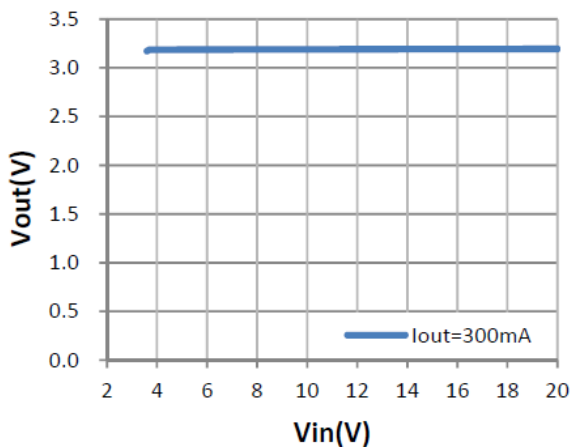

**Zero Load Operating Current vs.  $V_{in}$**

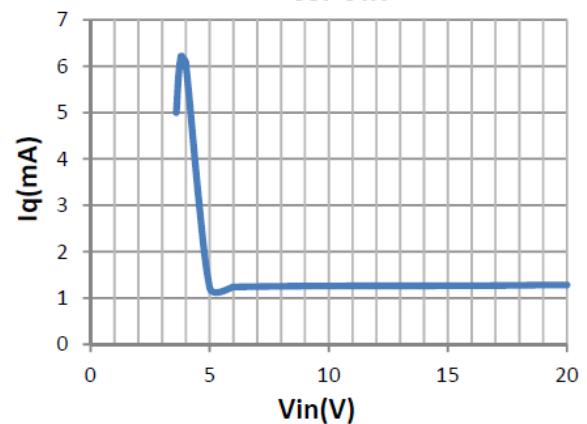

**Switching waveform  $V_{in}=18V$ ,  $I_{out}=0$**

(CH1= $V_{in}$ , CH2= $V_{out}$ , CH3=SW, CH4= $I_{sw}$ )

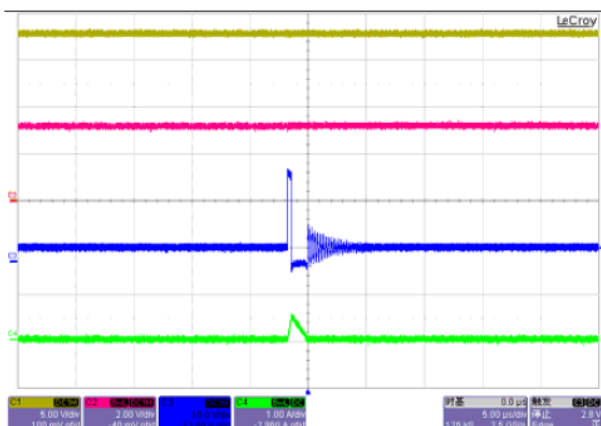

**Switching waveform  $V_{in}=18V$ ,  $I_{out}=2A$**

(CH1= $V_{in}$ , CH2= $V_{out}$ , CH3=SW, CH4= $I_{sw}$ )

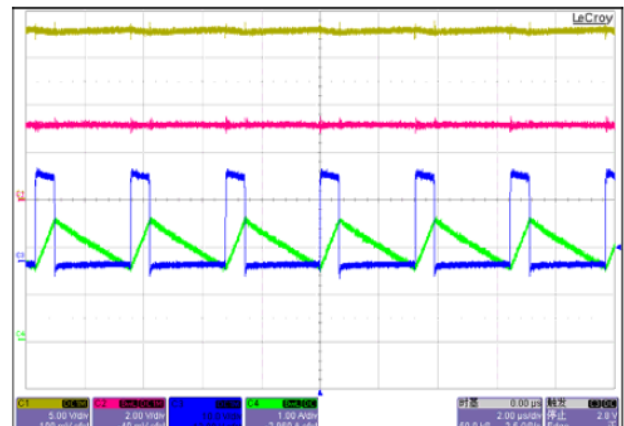



### Typical performance characteristics

( $V_{in}=12V$ ,  $V_{out}=3.3V$ ,  $L=10\mu H$ ,  $C_{in}=10\mu F$ ,  $C_{out}=22\mu F$ ,  $T_A=25^\circ C$ , unless otherwise stated)

#### Switching waveform $V_{in}=5V$ , $I_{out}=0$

(CH1= $V_{in}$ , CH2= $V_{out}$ , CH3=SW, CH4= $I_{sw}$ )

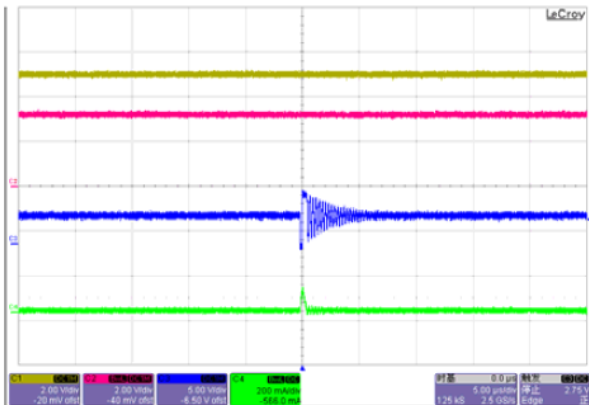

#### Switching waveform $V_{in}=5V$ , $I_{out}=2A$

(CH1= $V_{in}$ , CH2= $V_{out}$ , CH3=SW, CH4= $I_{sw}$ )

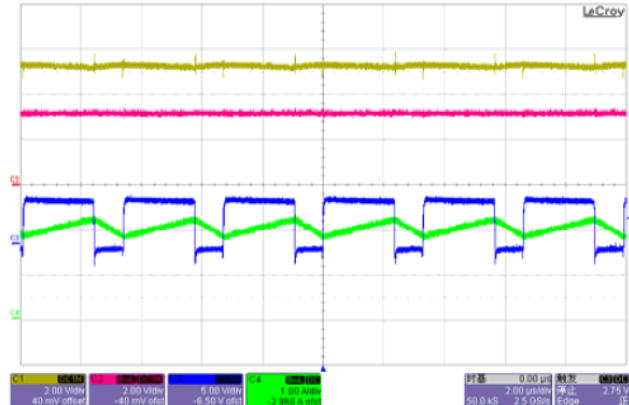

### Functional Descriptions

#### Loop Operation

The ACE724C is a wide input range, high-efficiency, DC-to-DC step-down switching regulator, capable of delivering up to 2.5A of output current, integrated with a 110m synchronous MOSFET, eliminating the need for external diode. It uses a PWM current-mode control scheme. An error amplifier integrates error between the FB signal and the internal reference voltage. The output of the integrator is then compared to the sum of a current-sense signal and the slope compensation ramp. This operation generates a PWM signal that modulates the duty cycle of the power MOSFETs to achieve regulation for output voltage.

#### Current Limit

There is a cycle-by-cycle current limit on the high-side MOSFET of 3.8A (typ). When the current flowing out of SW exceeds this limit, the high-side MOSFET turns off and the synchronous rectifier turns on. Unlike the traditional method of current limiting by limiting the voltage at the compensation pin, which usually has large variation due to duty cycle variance, this type of peak current limiting scheme provides a relatively more accurate limit for output current, thereby lowering the requirements for system design.

#### Light Load Operation

Traditionally, a fixed current mode constant frequency PWM DC-DC regulator always switches even when the output load is small. When energy is shuffling back and forth through the power MOSFETs, power is lost due to the finite RDSONs of the MOSFETs and parasitic capacitances. At light load, this loss is prominent and efficiency is therefore very low. ACE724C employs a proprietary control scheme that improves efficiency in this situation by enabling the device into a power save mode during light load, thereby extending the range of high efficiency operation.



# ACE724C

## 18V 2.5A Synchronous PFM/PWM Buck Converter

### Faster Transient Response

Normally, people use 3.3nF and 5.6Kohm RC for compensation to keep the loop stable. However, if one needs to have faster load transient response, 3.3nF and 8.5Kohm is recommended.

### Component selection

When setting up the ACE724C for different output voltage, please use following recommended component value for the best performance.

| V <sub>OUT</sub> (V) | C <sub>OUT</sub> ( $\mu$ F) | L( $\mu$ H) |
|----------------------|-----------------------------|-------------|
| 8                    | 22*2                        | 22          |
| 5                    | 22*2                        | 15          |
| 3.3                  | 22*2                        | 10          |
| 2.5                  | 22*2                        | 6.8         |
| 1.8                  | 22*2                        | 4.7         |
| 1.2                  | 22*2                        | 3.3         |

### Thermal consideration

ACE724C is high efficiency Buck converter, which means it consumes very few power when converting the high voltage to low voltage. However, when output power is very large, like 5V/2A, the output power is as high as 10W, a heat dissipation path is strongly recommended to be routed on PCB. ACE724C has two different SOP8 package. For the normal SOP8, the heat is conducted out via Pin 4 (GND), so the heat dissipation route on PCB should be connected to the Pin 4 of the chip. If ESOP8 is selected, the heat dissipation copper area should be exposed and connected to the exposed pad underneath the chip body.

When output power is larger than 10W, the ESOP8 package is recommended.



# ACE724C

## 18V 2.5A Synchronous PFM/PWM Buck Converter

### Packing Information

#### SOP-8

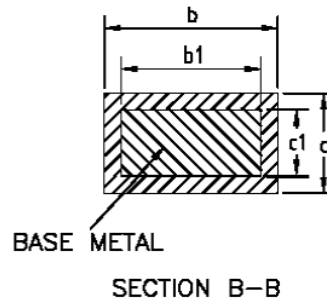
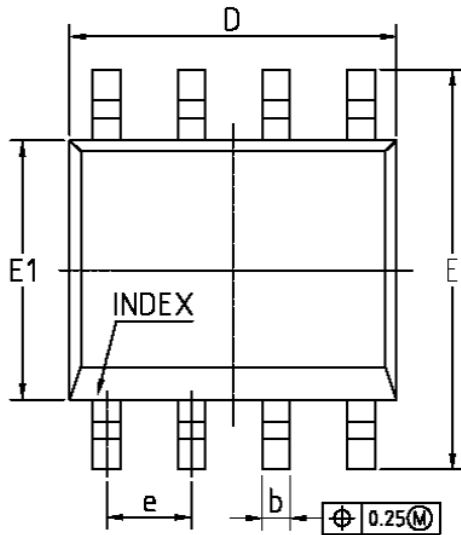
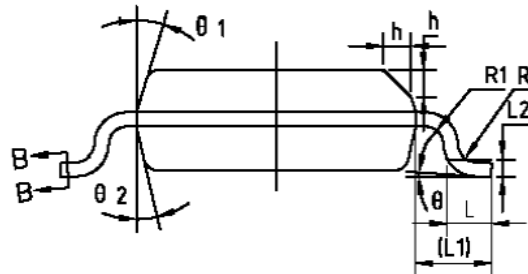
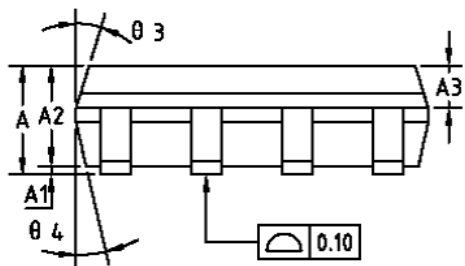

COMMON DIMENSIONS  
(UNITS OF MEASURE=MILLIMETER)

| SYMBOL | MIN     | NOM  | MAX  |
|--------|---------|------|------|
| A      | 1.35    | 1.55 | 1.75 |
| A1     | 0.10    | 0.15 | 0.25 |
| A2     | 1.25    | 1.40 | 1.65 |
| A3     | 0.50    | 0.60 | 0.70 |
| b      | 0.38    | —    | 0.51 |
| b1     | 0.37    | 0.42 | 0.47 |
| c      | 0.17    | —    | 0.25 |
| c1     | 0.17    | 0.20 | 0.23 |
| D      | 4.80    | 4.90 | 5.00 |
| E      | 5.80    | 6.00 | 6.20 |
| E1     | 3.80    | 3.90 | 4.00 |
| e      | 1.27BSC |      |      |
| L      | 0.45    | 0.60 | 0.80 |
| L1     | 1.04REF |      |      |
| L2     | 0.25BSC |      |      |
| R      | 0.07    | —    | —    |
| R1     | 0.07    | —    | —    |
| h      | 0.30    | 0.40 | 0.50 |
| θ      | 0°      | —    | 8°   |
| θ 1    | 15°     | 17°  | 19°  |
| θ 2    | 11°     | 13°  | 15°  |
| θ 3    | 15°     | 17°  | 19°  |
| θ 4    | 11°     | 13°  | 15°  |





**Packing Information**

**ESOP-8**

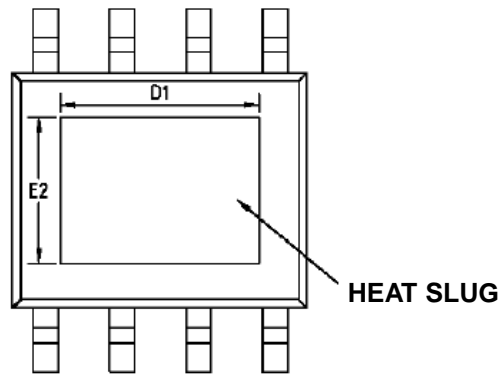
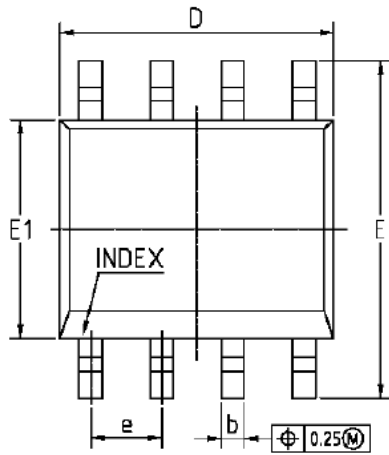
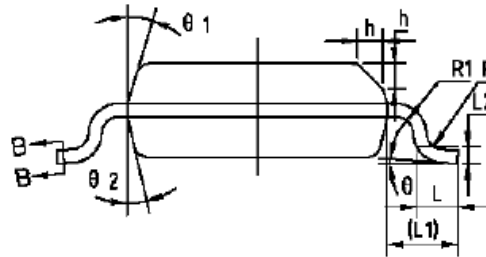
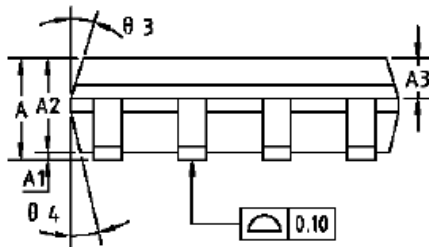

**(BTM)**

**NOTES: ALL DIMENSIONS REFER TO JEDEC STANDARD MS-012 AA DO NOT INCLUDE MOLD FLASH OR PROTRUSIONS.**

**COMMON DIMENSIONS  
(UNITS OF MEASURE=MILLIMETER)**

| SYMBOL  | MIN     | NOM  | MAX  |
|---------|---------|------|------|
| A       | 1.35    | 1.55 | 1.75 |
| A1      | 0       | 0.10 | 0.15 |
| A2      | 1.25    | 1.40 | 1.65 |
| A3      | 0.50    | 0.80 | 0.70 |
| b       | 0.38    | —    | 0.51 |
| b1      | 0.37    | 0.42 | 0.47 |
| c       | 0.17    | —    | 0.25 |
| c1      | 0.17    | 0.20 | 0.23 |
| D       | 4.80    | 4.90 | 5.00 |
| D1      | 3.10    | 3.30 | 3.50 |
| E       | 5.80    | 6.00 | 6.20 |
| E1      | 3.80    | 3.90 | 4.00 |
| E2      | 2.20    | 2.40 | 2.60 |
| e       | 1.27BSC |      |      |
| L       | 0.45    | 0.60 | 0.80 |
| L1      | 1.04REF |      |      |
| L2      | 0.25BSC |      |      |
| R       | 0.07    | —    | —    |
| R1      | 0.07    | —    | —    |
| h       | 0.30    | 0.40 | 0.50 |
| theta   | 0°      | —    | 8°   |
| theta 1 | 15°     | 17°  | 19°  |
| theta 2 | 11°     | 13°  | 15°  |
| theta 3 | 15°     | 17°  | 19°  |
| theta 4 | 11°     | 13°  | 15°  |

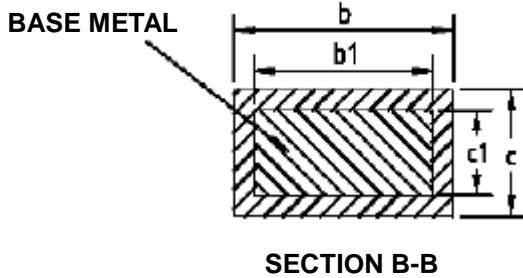



# ACE724C

## 18V 2.5A Synchronous PFM/PWM Buck Converter

### Notes

ACE does not assume any responsibility for use as critical components in life support devices or systems without the express written approval of the president and general counsel of ACE Electronics Co., LTD. As used herein:

1. Life support devices or systems are devices or systems which, (a) are intended for surgical implant into the body, or (b) support or sustain life, and whose failure to perform when properly used in accordance with instructions for use provided in the labeling, can be reasonably expected to result in a significant injury to the user.
2. A critical component is any component of a life support device or system whose failure to perform can be reasonably expected to cause the failure of the life support device or system, or to affect its safety or effectiveness.

ACE Technology Co., LTD.  
<http://www.ace-ele.com/>