



ACE501

300mA CMOS Low Dropout Voltage Low consumption Regulator

Description

ACE501 series is a group of positive voltage output, low power consumption, low dropout voltage, three terminal regulator. It can provide 300mA output current when input / output voltage differential drops to 500mV ($V_{in}=4.0V$, $V_{out}=3.0V$). The very low power consumption of ACE501 ($I_q=1.0\mu A$) can greatly improve natural life of batteries.

ACE501 can provide output value in the range of 1.1V~5.5V in 0.1V steps. It also can customized on command.

ACE501 includes high accuracy voltage reference, error amplifier, current limit circuit and output driver module.

ACE501 has well load transient response and good temperature characteristic, which can assure the stability of chip and power system, And it uses trimming technique to guarantee output voltage accuracy within $\pm 2\%$.

Features

- Low Power Consumption: 1.0uA (Typ)
- Maximum Output Current: 300mA
- Small Dropout Voltage 150mV@100mA ($V_{out}=3.0V$) / 310mV@200mA ($V_{out}=3.0V$)
- Input Voltage Range: 1.5V~10V
- Output Voltage Range: 1.1V~5.5V (customized on command in 0.1V steps)
- High Accurate: $\pm 2\%$ ($\pm 1\%$ customized)
- Output Current Limit

Application

- Battery Powered equipment
- Power Management of MP3. PDA. DSC. Mouse. PS2 Games
- Reference Voltage Source
- Regulation after Switching Power

Typical Performance Characteristic:

Output Voltage vs. Output Current

ELECTRICAL CHARACTERISTICS

Load Regulation

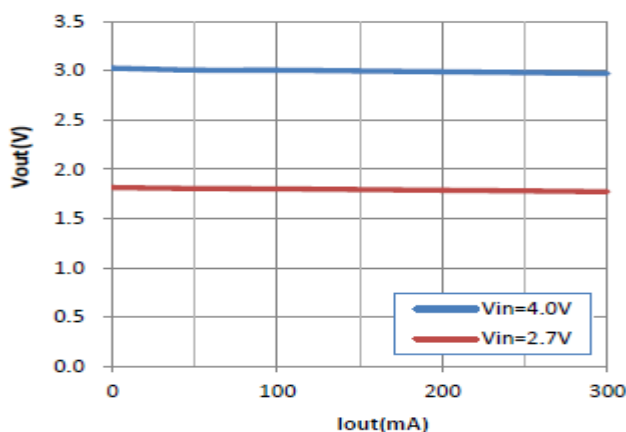



ACE501

300mA CMOS Low Dropout Voltage Low consumption Regulator

Absolute Maximum Ratings

Parameter	Symbol	Max	Unit
Input supply voltage	V_{IN}	10	V
Power Dissipation			
SOT-89-3		500	mW
SOT-23-3L		250	
SOT-23-5		250	
TO-92		500	
Junction temperature	T_J	125	°C
Storage temperature	T_S	- 45 to 150	°C
Ambient Temperature	T_A	-40 ~85	°C

Packaging Type

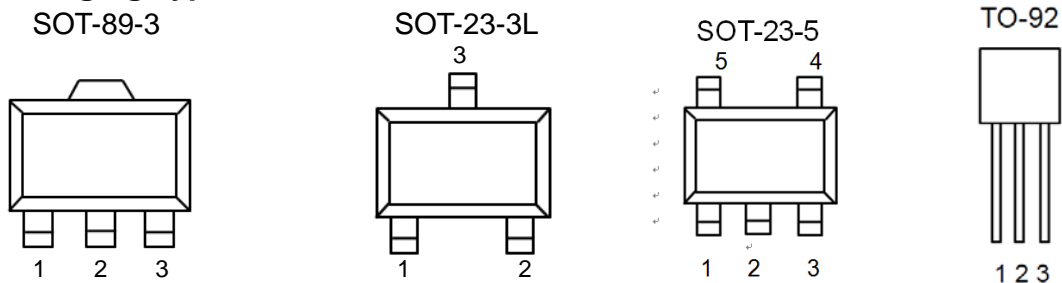

Description	SOT-89-3	SOT-23-3L	SOT-23-5	TO-92	Function
V_{SS}	1	1	1	1	Ground
V_{IN}	2	3	2	2	Supply Voltage Input
V_{OUT}	3	2	3	3	Output Voltage
NC			4		
NC			5		

Ordering information

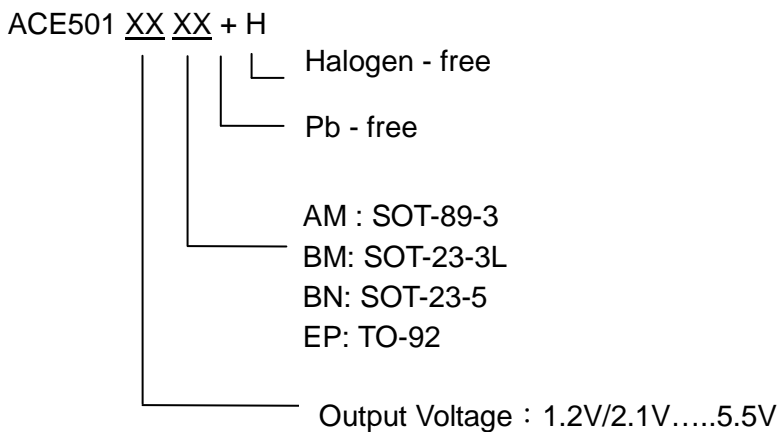



Recommended Work Conditions

Item	Min	Max	Unit
Input Voltage Range		8	V
Ambient Temperature	-40	+85	°C

Electrical Characteristics

(Test Conditions: $C_{in}=1\mu F$, $C_{out}=1\mu F$, $T_A=25^\circ C$, unless otherwise specified.)

Parameter	Symbol	Conditions	Min	Typ	Max	Units
Input Voltage	V_{IN}				8	V
Output Voltage	V_{OUT}		$V_{out} \times 0.98$		$V_{out} \times 1.02$	V
Maximum Output Current	$I_{OUT(Max.)}$	$V_{IN}=2.5V$, $V_{OUT}>1.47$	300			mA
Input-Output Voltage Differential	Dropout Voltage	$I_{OUT}=100mA$	$V_{out} \leq 1.8V$	500	800	mV
			$V_{out} \geq 1.8V$	260	500	
Line Regulation	$\frac{\Delta V_{OUT}}{\Delta V_{IN}} \cdot V_{OUT}$	$I_{OUT}=10mA$ $1.5V \leq V_{IN} \leq 8V$		0.2	0.3	%/V
Load Regulation	ΔV_{OUT}	$V_{IN}=Set\ V_{out}+1V$ $1mA \leq I_{OUT} \leq 100mA$		20	40	mV
Quiescent Current	I_q	$V_{IN}=Set\ V_{out}+1V$		1.0	5.0	uA
Output Voltage Temperature Coefficient	$\frac{\Delta V_{OUT}}{\Delta T} \cdot V_{OUT}$	$I_{OUT}=10mA$		100		ppm/°C

Typical Application Circuit

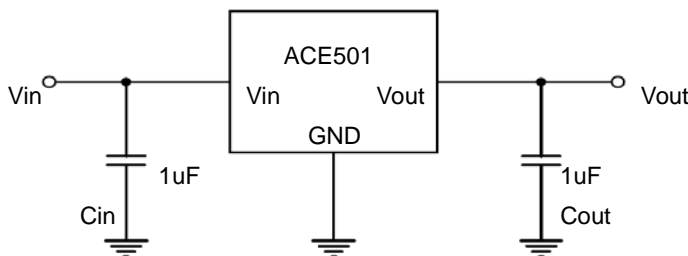

Application hints:

Note 1: Input capacitor ($C_{in}=1\mu F$) is recommended in all application circuit. Tantalum capacitor is recommended.

Note 2: Output capacitor ($C_{out}=1\mu F$) is recommended in all application to assure the stability of circuit. Tantalum capacitor is recommended.



ACE501

300mA CMOS Low Dropout Voltage Low consumption Regulator

BLOCK DIAGRAM

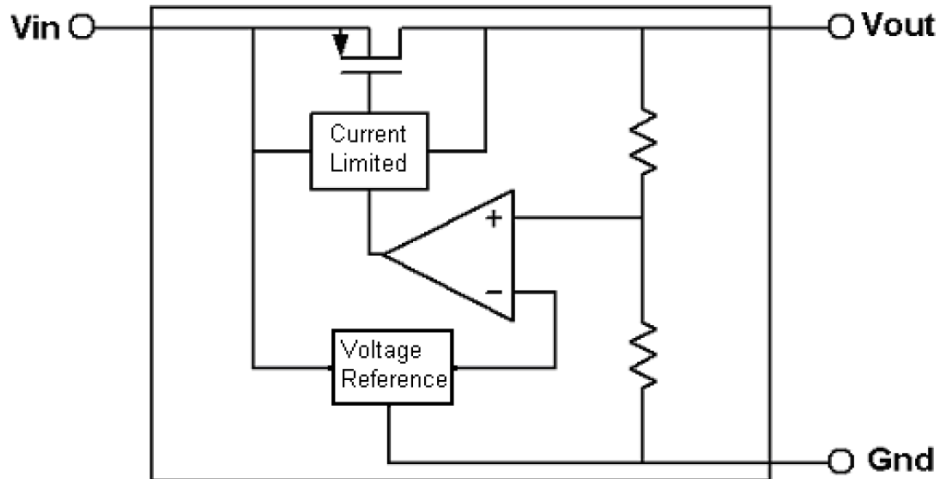

EXPLANATION

ACE501 is a series of low dropout voltage and low power consumption three pins regulator. Its application circuit is very simple, which only needs two outside capacitors. It is composed of these modules: high Accuracy voltage reference, current limit circuit, error amplifier, output driver and power transistor.

Current Limit module can keep chip and power system away from danger when load current is more than 300mA.

ACE501 uses trimming technique to assure the accuracy of output value withing $\pm 2\%$ at the same time, temperature compensation is elaborately considered in this chip, which makes ACE501 temperature coefficient within $100\text{ppm}/^\circ\text{C}$.



Typical Performance Characteristics

1. Load regulation

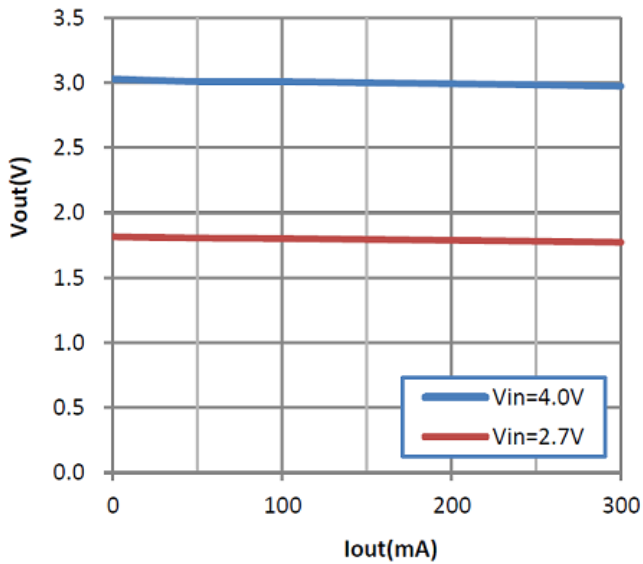

2. Line regulation

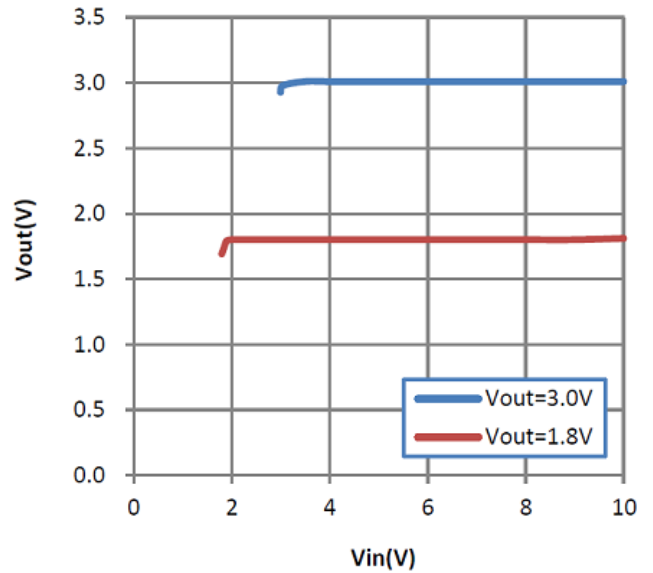

3. Dropout Voltage

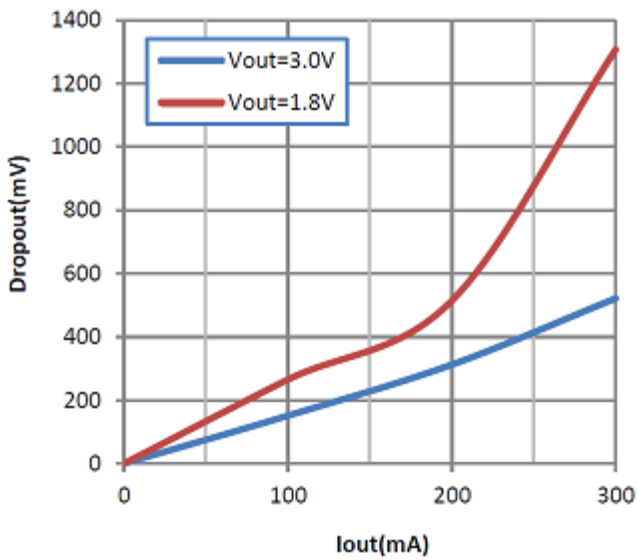

4. Iq

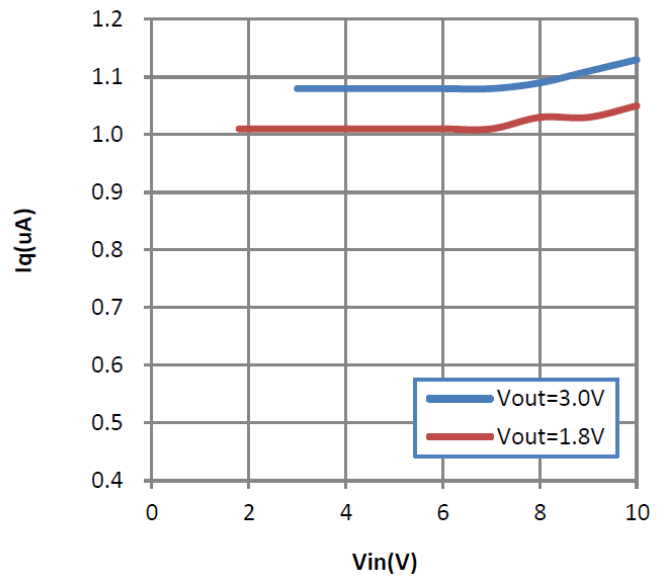



ACE501

300mA CMOS Low Dropout Voltage Low consumption Regulator

Current Limit

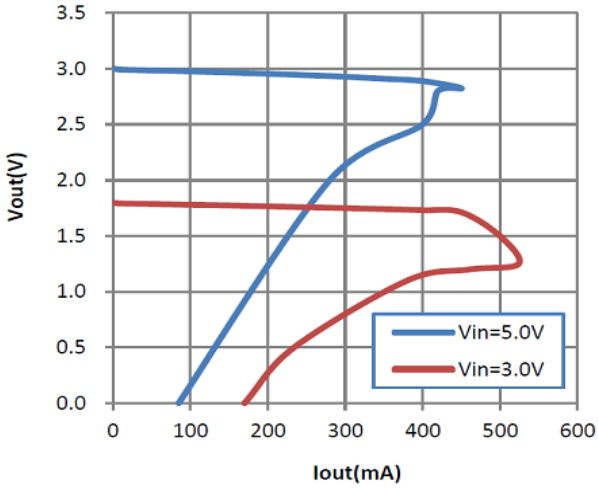

Line transien

Vin=4V~5V, Cir

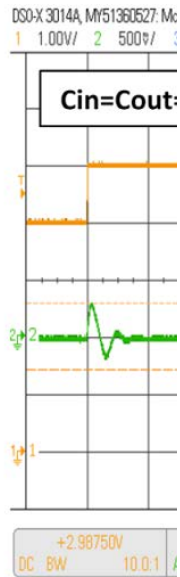

DSO-X 3014A, MY51360527, Mon Jan 07 09:55:53 2013

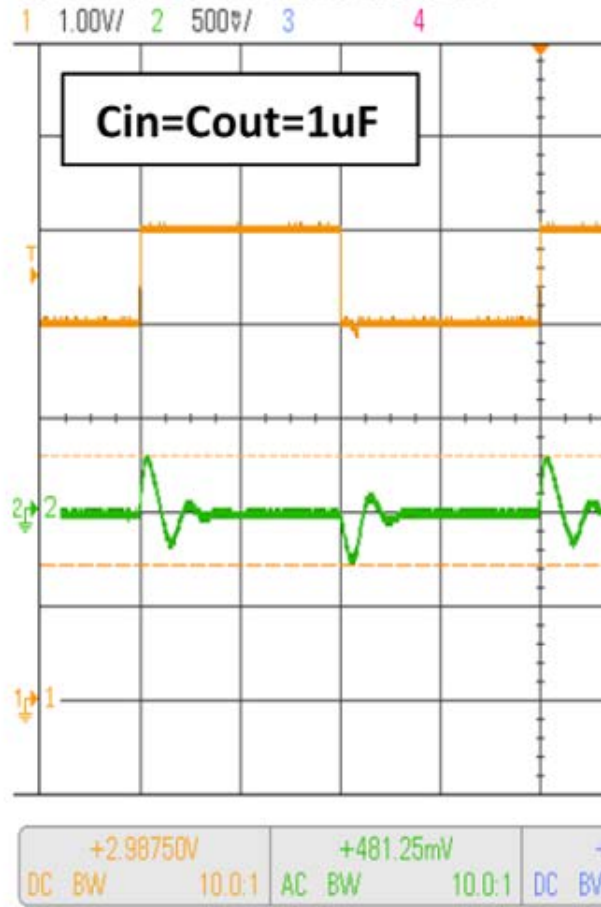

Load transient response

Iout=1mA~40mA, Vout=3.0V, Vin=4V, Cin=Cout=1uF, Ch1—Vout, Ch4—Io

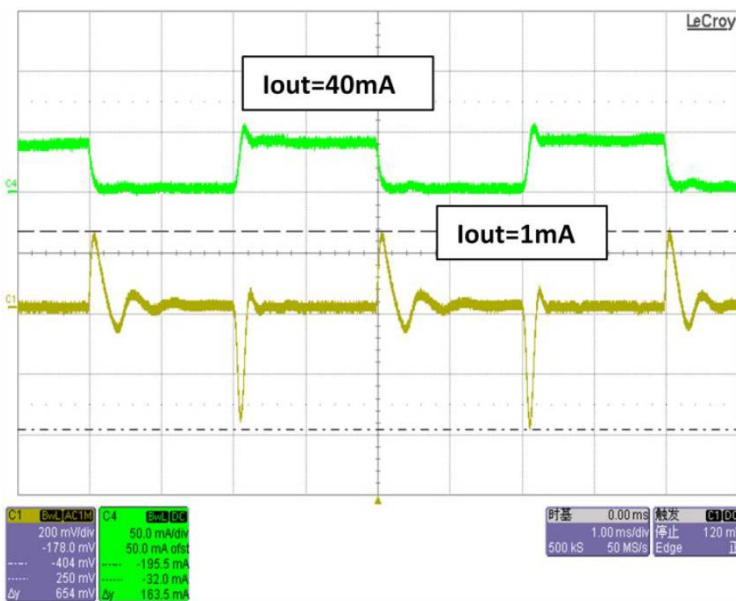



ACE501

300mA CMOS Low Dropout Voltage Low consumption Regulator

Packing Information

SOT-89-3

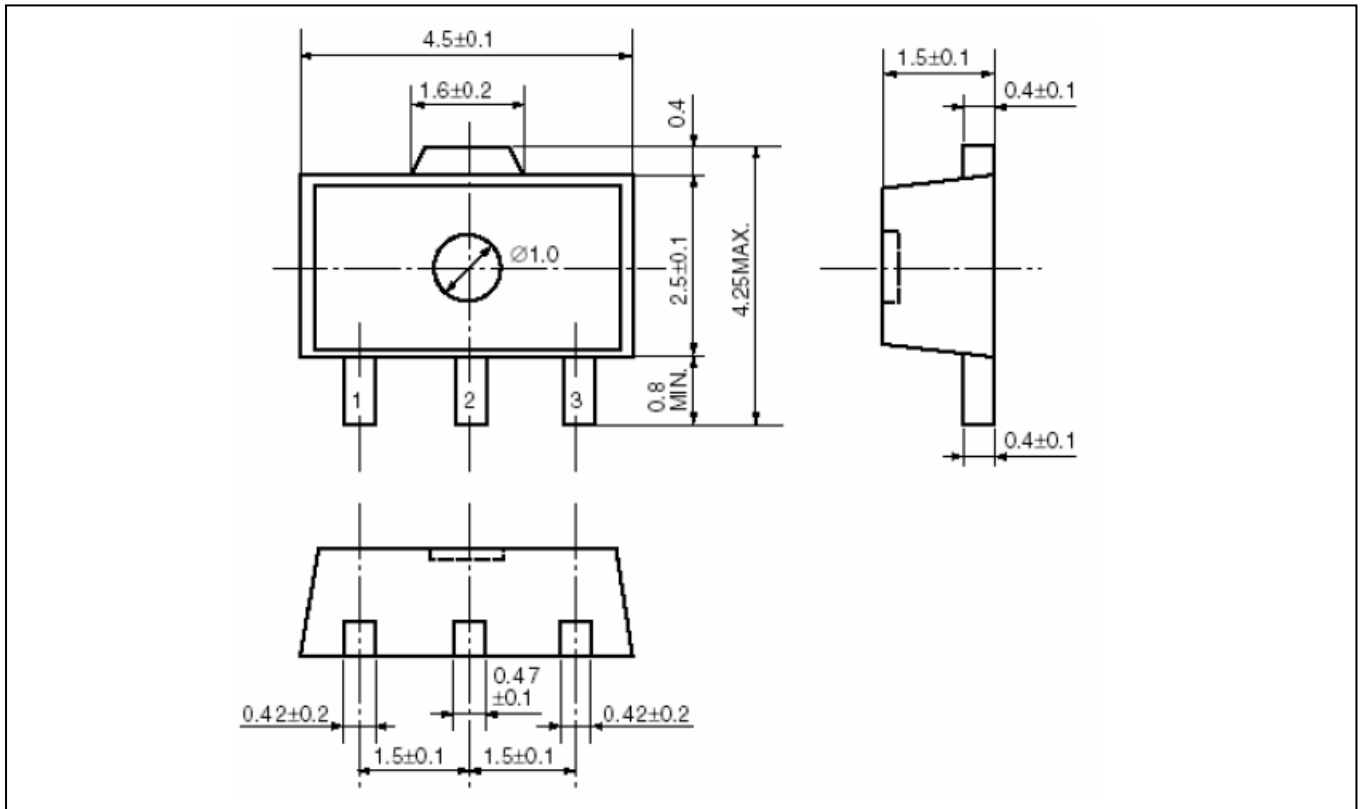

SOT-23-3L

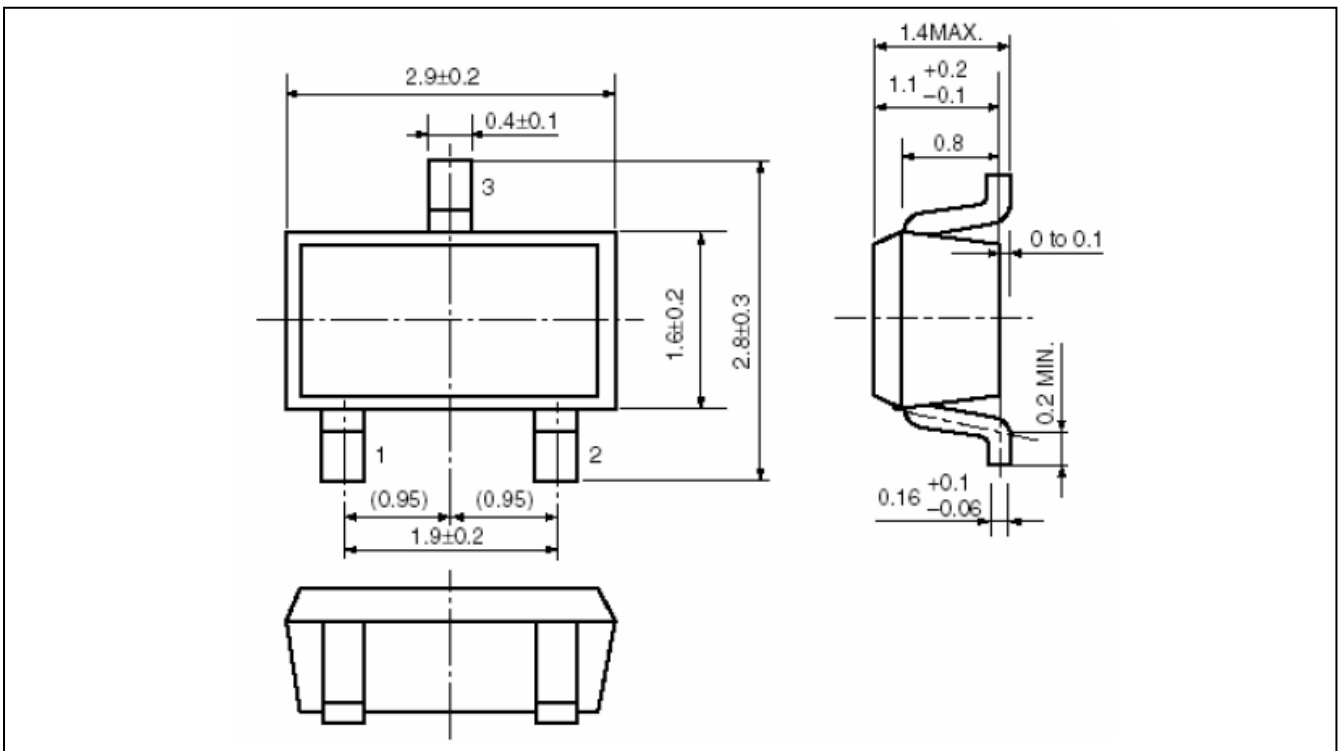



ACE501

300mA CMOS Low Dropout Voltage Low consumption Regulator

SOT-23-5

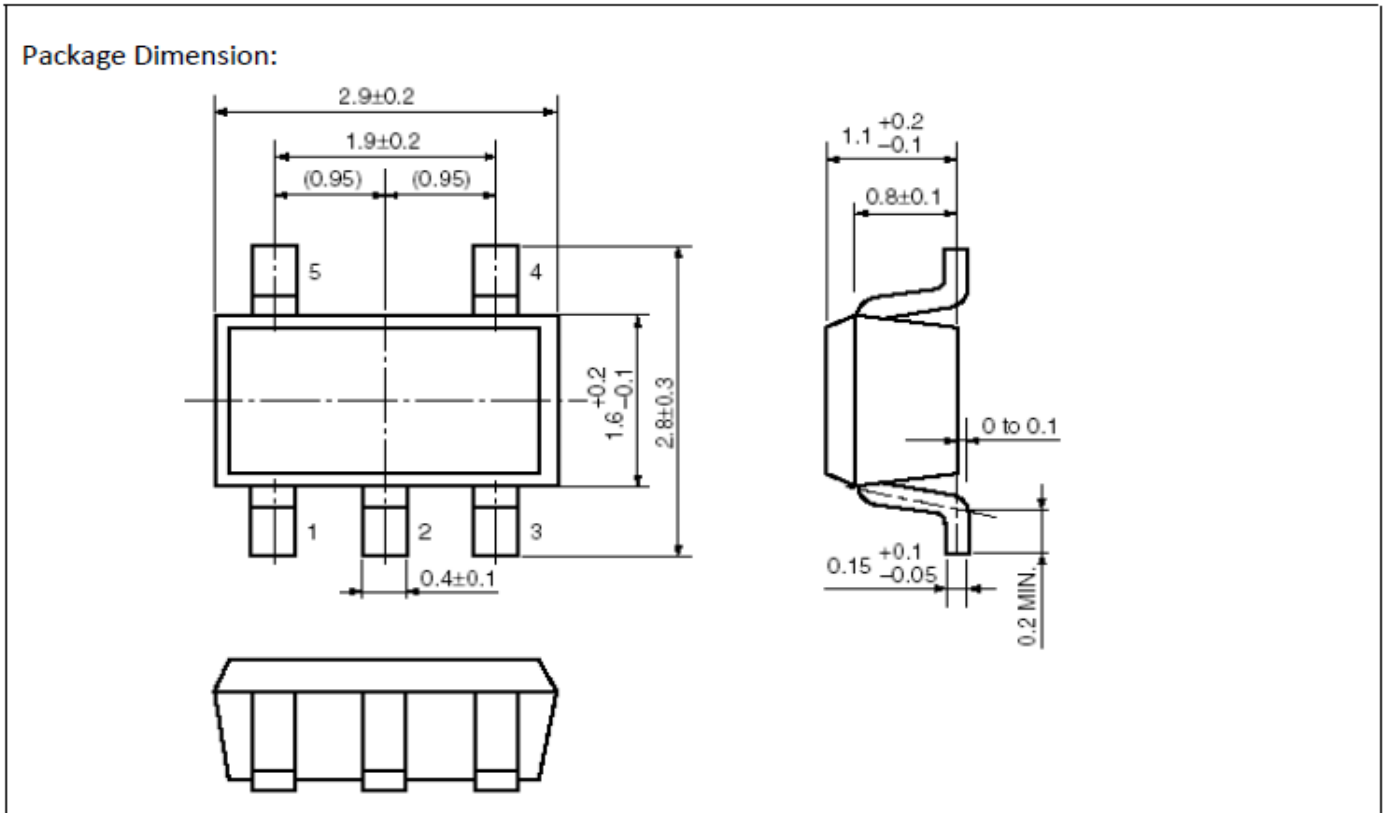

TO-92

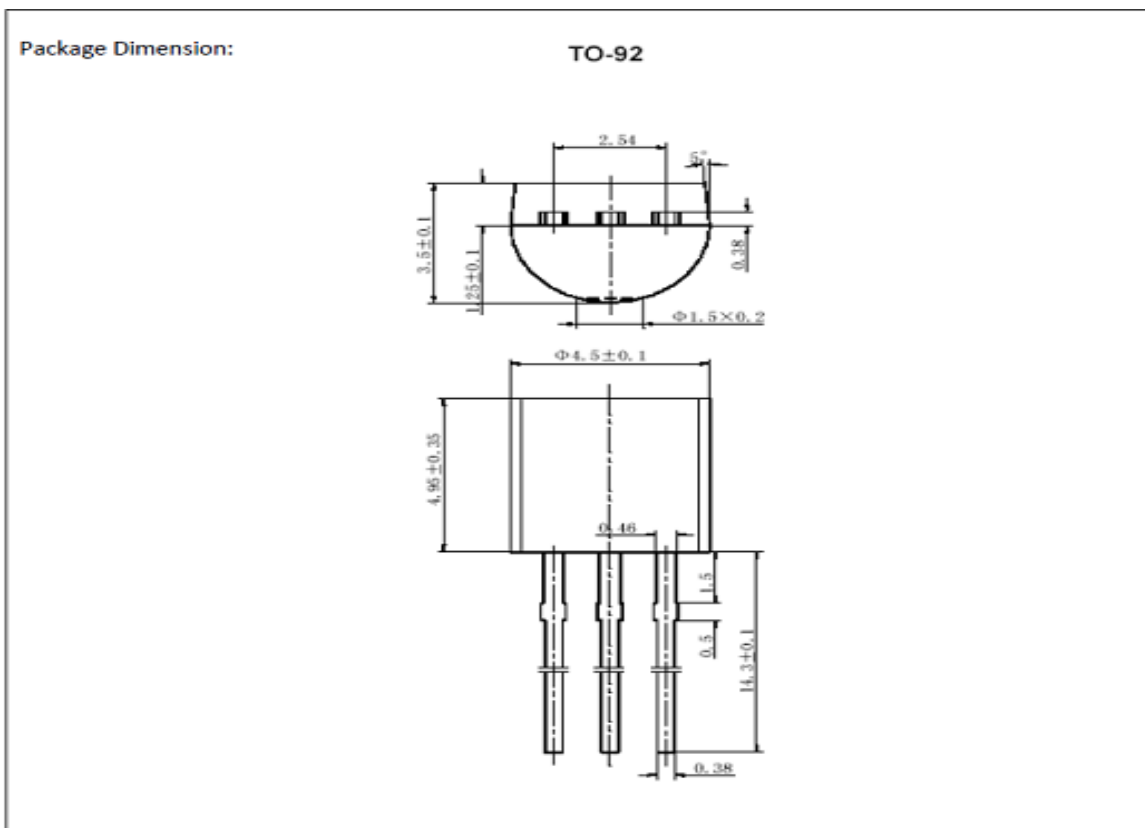



ACE501

300mA CMOS Low Dropout Voltage Low consumption Regulator

Notes

ACE does not assume any responsibility for use as critical components in life support devices or systems without the express written approval of the president and general counsel of ACE Electronics Co., LTD. As used herein:

1. Life support devices or systems are devices or systems which, (a) are intended for surgical implant into the body, or (b) support or sustain life, and whose failure to perform when properly used in accordance with instructions for use provided in the labeling, can be reasonably expected to result in a significant injury to the user.
2. A critical component is any component of a life support device or system whose failure to perform can be reasonably expected to cause the failure of the life support device or system, or to affect its safety or effectiveness.

ACE Technology Co., LTD.
<http://www.ace-ele.com/>