



# ACE621E

## Ultra-Fast High PSRR 1.5A CMOS Voltage Regulator

### Description

ACE621E series are a group of positive voltage regulators manufactured by CMOS technology with high ripple rejection, ultra-fast transient response and low dropout voltage, which consume less than 1 $\mu$ A in shutdown mode and can provide large output currents even when the difference of the input-output voltage is small. Each of the ACE621E series consists of a high-precision voltage reference, an error correction circuit, and a current limited output driver. Thus the series are very suitable for the battery-powered equipments, wireless communication applications, industry equipments and so on.

### Features

- Shutdown Current: <1 $\mu$ A
- Guaranteed Output Current: 1.5A (Typ.)
- Low Quiescent Current: 50 $\mu$ A (Typ.)
- Output Voltage Range: 1.5V~5.0V
- Input Voltage Range: 2.5V~6.0V
- High Accuracy:  $\pm$ 2% (Typ.)
- Dropout Voltage: [600mV@1.5A](#) (3.0V Typ.)
- Excellent Line Regulation: 0.02%/V
- High PSRR: 70dB@1KHz
- Built-in Current Limiter & Thermal Protection.
- Short Circuit Current Fold-back

### Application

- Battery powered systems
- Portable instrumentations
- PC peripherals
- CD/DVD-ROM, CD/RW
- Wireless devices
- Battery charger

### Absolute Maximum Ratings

(Unless otherwise specified, Ta=25 $^{\circ}$ C)

Parameter	Symbol	Ratings	Units	
Input Voltage	V <sub>IN</sub>	V <sub>SS</sub> -0.3~V <sub>SS</sub> +7	V	
Output Current	I <sub>OUT</sub>	1.5	mA	
Output Voltage	V <sub>out</sub>	V <sub>SS</sub> -0.3~V <sub>IN</sub> +0.3	V	
Power Dissipation	SOT-89-5	P <sub>d</sub>	600	mW
	SOP8-PP	P <sub>d</sub>	1500	mW
Operating Temperature	T <sub>opr</sub>	-40~+85	$^{\circ}$ C	
Storage Temperature	T <sub>stg</sub>	-40~+125	$^{\circ}$ C	
Soldering Temperature & Time	T <sub>solder</sub>	260 $^{\circ}$ C, 10s		



# ACE621E

## Ultra-Fast High PSRR 1.5A CMOS Voltage Regulator

### Packaging Type

SOT-89-5

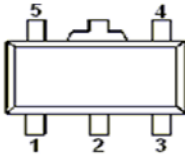

SOP-8

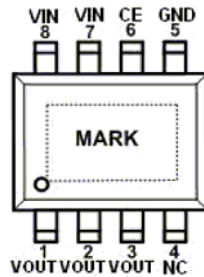

PIN NUMBER		PIN NAME	Function
SOT-89-5	SOP-8		
1	6	CE	Chip Enable
4	7,8	V <sub>in</sub>	Ground
2	5	V <sub>SS</sub>	Power input
5	1,2,3	V <sub>out</sub>	Output
3	4	NC	No Connection
	Exposed Thermal PAD	Thermal PAD	Connect to GND

### Ordering information

ACE621E XX XX + H

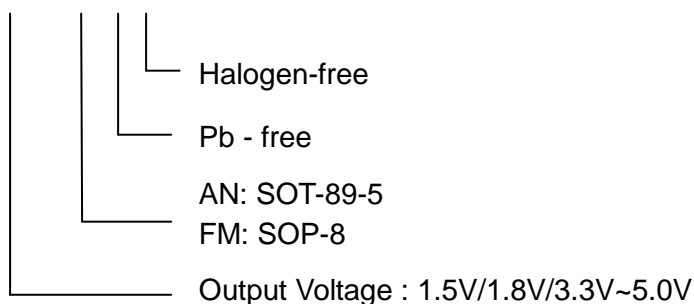



# ACE621E

## Ultra-Fast High PSRR 1.5A CMOS Voltage Regulator

### Block Diagram

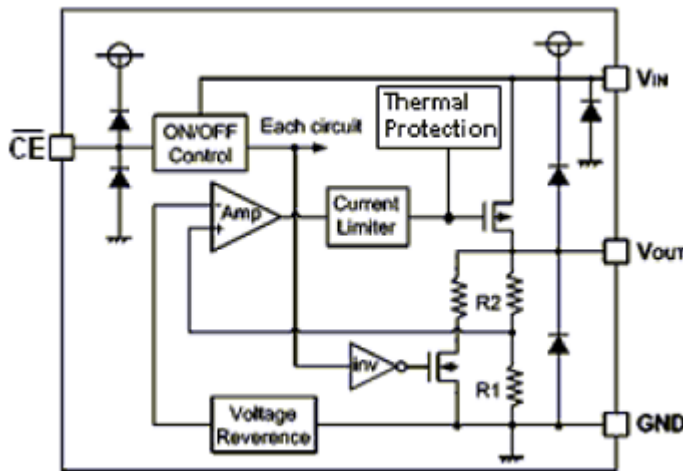

### Electrical Characteristics

ACE621E, For Arbitrary Output Voltage.(Test Conditions:  $C_{in}=C_{OUT}=4.7\mu F$ ,  $T_a=25^\circ C$ , unless otherwise specified.)

Symbol	Parameter	Conditions	Min	Typ	Max	Units
$V_{OUT}$ (E) (Note 2)	Output Voltage	$V_{IN}=V_{OUT}+1V$ $I_{OUT}=100mA$	$V_{OUT}$ $*0.98$	$V_{OUT}$ (Note1)	$V_{OUT}$ $*1.02$	V
$I_Q$	Supply Current	$V_{IN}=V_{OUT}+1V$ , $V_{CE}=GND$		50	100	$\mu A$
$I_{SHDN}$	Shutdown Current	$V_{CE}=V_{IN}$		0.1	1.0	$\mu A$
$I_{OUT}$	Output Current	$V_{IN}=V_{OUT}+2V$ ( $V_{OUT}<4V$ ) $V_{IN}=V_{OUT}+1V$ ( $V_{OUT}\geq 4V$ )	1500			mA
$V_{dif}$	Dropout Voltage (Note 3)	$I_{OUT}=1.5A$	$1.5V\leq V_{OUT}\leq 2.0V$	1300		mV
			$2.0V<V_{OUT}\leq 2.8V$	800		mV
			$2.8V<V_{OUT}$	600		mV
$\Delta V_{out}$	Load Regulation	$V_{IN}=V_{OUT}+2V$ ( $V_{OUT}<4V$ ) $V_{IN}=V_{OUT}+1V$ ( $V_{OUT}\geq 4V$ ) $1mA\leq I_{OUT}\leq 1.5A$		30	100	mV
$\frac{\Delta V_{out}}{\Delta V_{IN}*V_{OUT}}$	Line Regulation	$I_{OUT}=100mA$ $V_{OUT}+1V\leq V_{IN}\leq 6V$		0.02	0.2	%/V
$\frac{\Delta V_{out}}{\Delta T*V_{OUT}}$	Output Voltage Temperature Characteristics	$I_{OUT}=100mA$ $-40^\circ C\leq T\leq 85^\circ C$		50		ppm/ $^\circ C$
$I_{Short}$	Short Current	$V_{OUT}=V_{SS}$		200		mA



# ACE621E

## Ultra-Fast High PSRR 1.5A CMOS Voltage Regulator

$V_{IN}$	Input Voltage		—	2.5	6.0	V
PSRR	Power Supply Rejection Rate	1KHz	$I_{OUT}=100mA$		70	dB
PSRR $V_{CE}$ "H"	Power Supply Rejection Rate CE "High" Voltage	10KHz	$I_{OUT}=100mA$ 1.5		50 $V_{IN}$	dB V
$V_{CE}$ "L"	CE "Low" Voltage				0.3	V
$T_{SD}$	Thermal Shutdown Temperature		—		150	°C
$\Delta T_{SD}$	Thermal Shutdown Temperature Hysteresis		—		30	°C

Note: 1.  $V_{OUT}$  : Specified Output Voltage.

2.  $V_{OUT}$  (E) : Effective Output Voltage (I.e. The Output Voltage When  $V_{IN}=(V_{OUT}+1.0V)$  And Maintain A Certain  $I_{OUT}$  Value).

3.  $V_{diff}$  : The Difference Of Output Voltage And Input Voltage When Input Voltage Is Decreased Gradually Till Output Voltage Equals To 98% Of  $V_{OUT}$  (E).

### Typical Application Circu

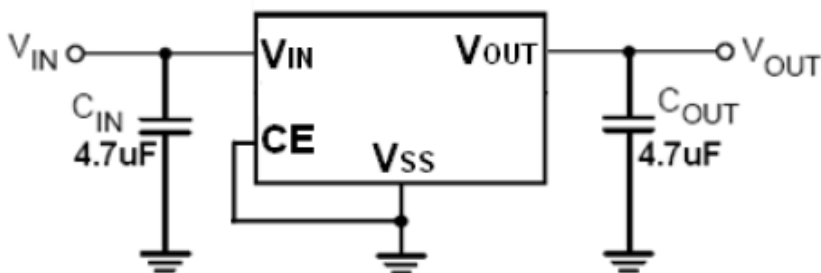

Note: Input capacitor ( $C_{IN}$ ) : 4.7 uF or more ;

Output capacitor(  $C_{OUT}$ ): : 4.7 uF or more ;

Caution : A general series regulator may oscillate, depending on the external components selected. Check that no oscillation occurs with the application using the above capacitor.



Typical Performance Characteristic:

(1) Input Transient Response

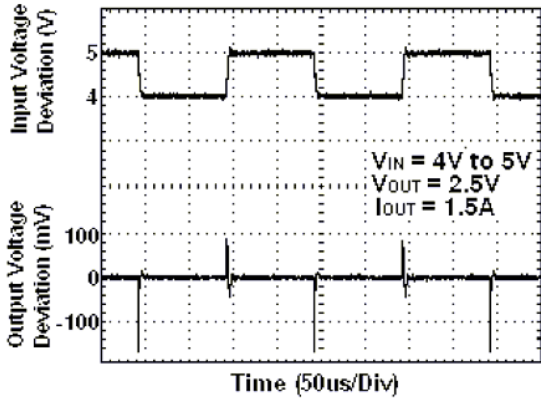

(2) Load Transient Response

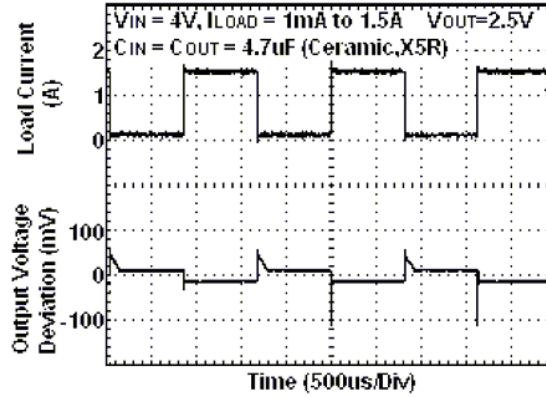

(3) Output Voltage vs. Temperature

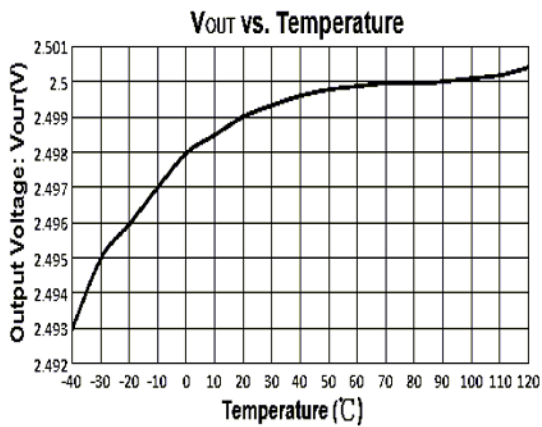

(4) Power Supply Rejection Ratio

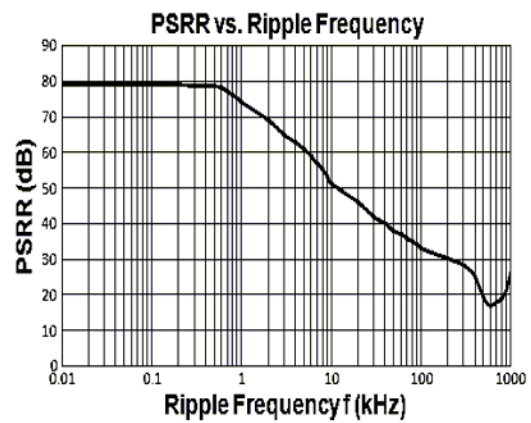

(5) Dropout Voltage vs. Output Current

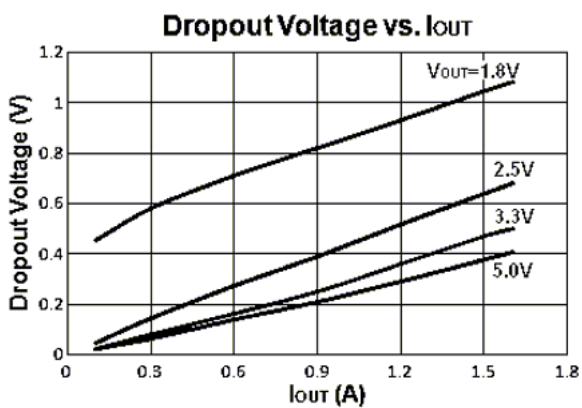

(6) Region of Stable  $C_{OUT}$  ESR vs. Load

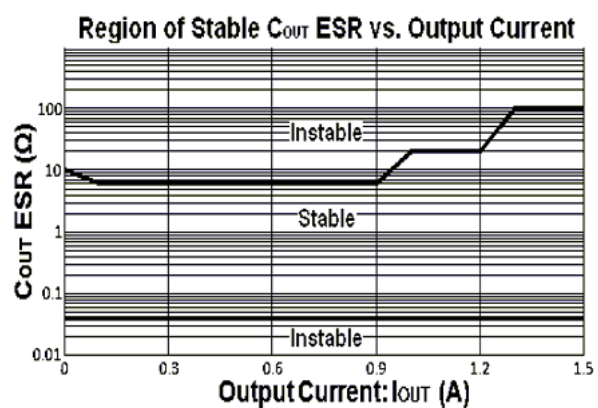



# ACE621E

## Ultra-Fast High PSRR 1.5A CMOS Voltage Regulator

### Packing Information

### SOP-89-5 PCAKAGE OUTLING DIMENSIONS

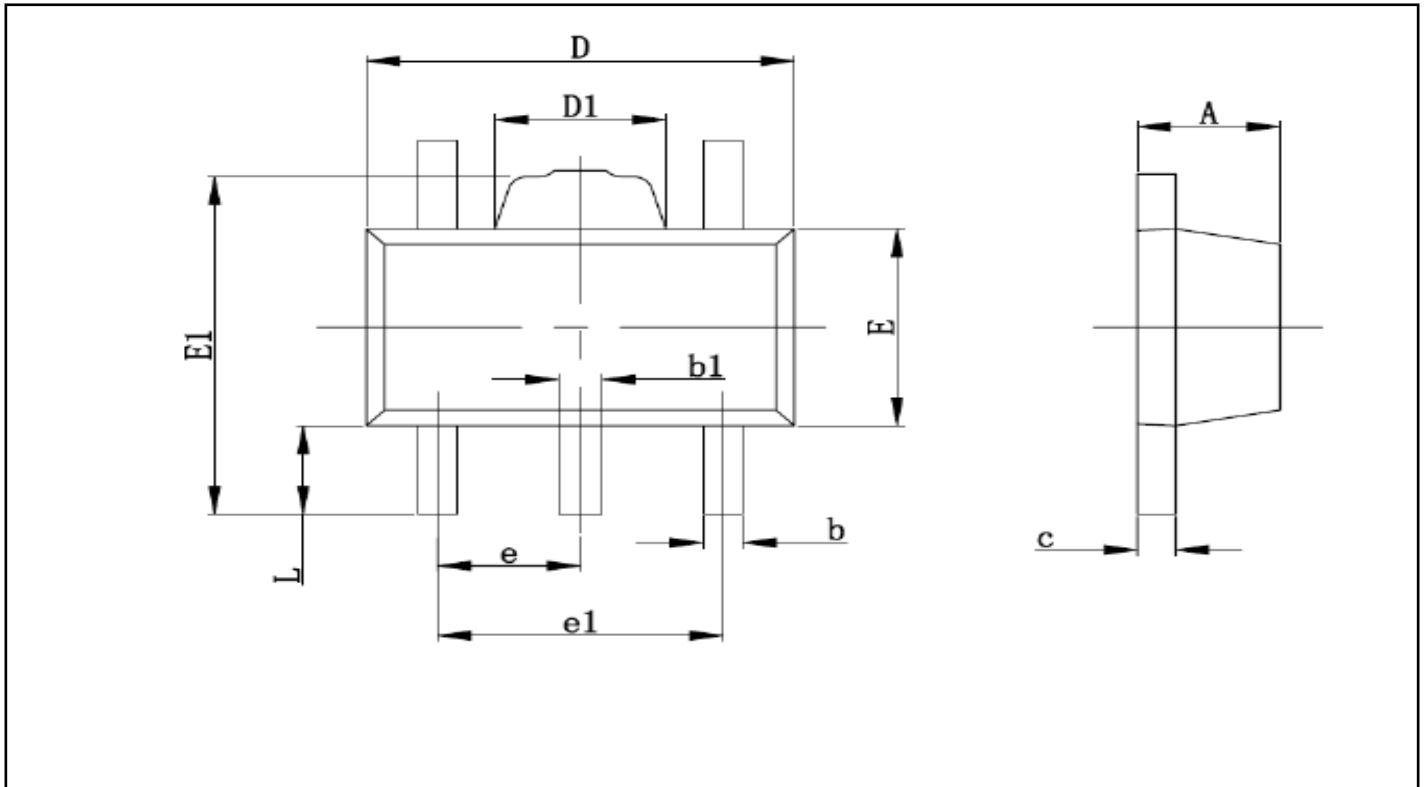

Symbol	Dimensions In Millimeters		Dimensions In Inches	
	Min.	Max.	Min.	Max.
A	1.400	1.600	0.055	0.063
b	0.320	0.520	0.013	0.020
b1	0.360	0.560	0.014	0.022
c	0.350	0.440	0.014	0.017
D	4.400	4.600	0.173	0.181
D1	1.400	1.800	0.055	0.071
E	2.300	2.600	0.091	0.102
E1	3.940	4.250	0.155	0.167
e	1.500TYP		0.060TYP	
e1	2.900	3.100	0.114	0.122
L	0.900	1.100	0.035	0.043



# ACE621E

## Ultra-Fast High PSRR 1.5A CMOS Voltage Regulator

### Packing Information

#### SOP-8

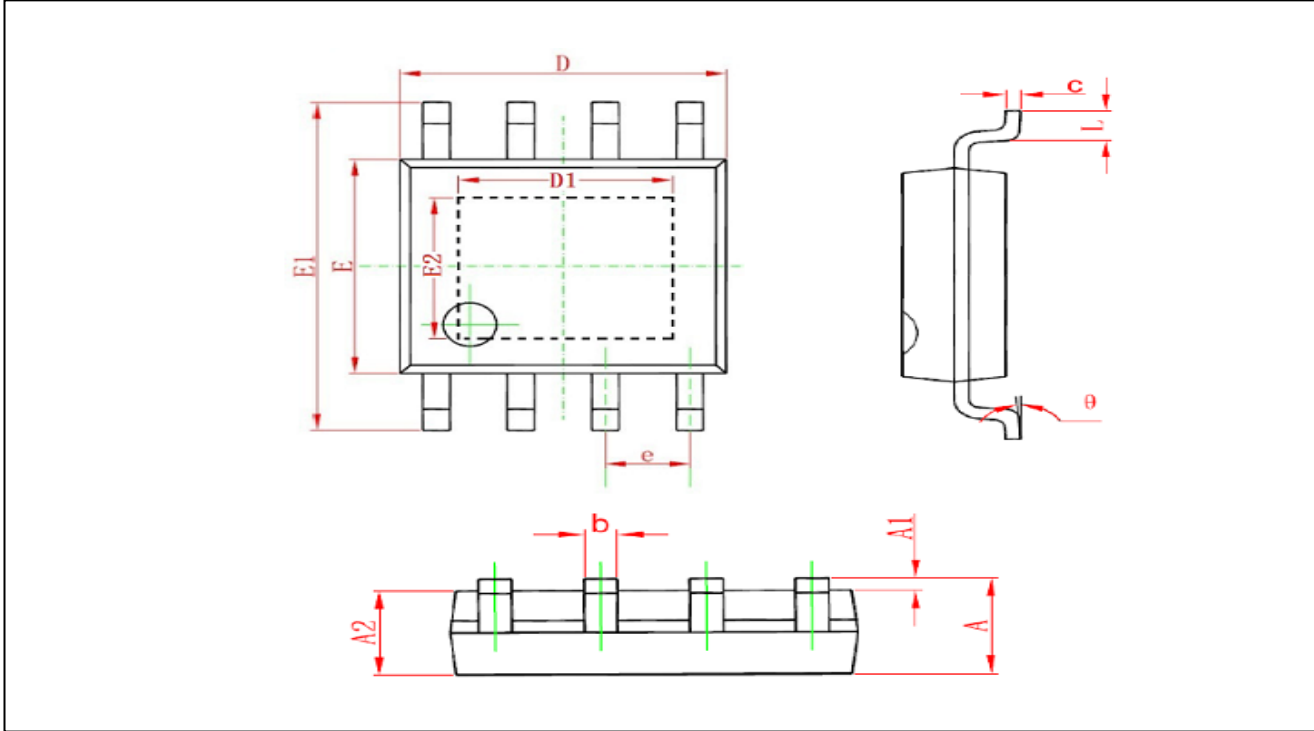

Symbol	Dimensions In Millimeters		Dimensions In Inches	
	Min.	Max.	Min.	Max.
A	1.350	1.750	0.053	0.069
A1	0.100	0.250	0.004	0.010
A2	1.350	1.550	0.053	0.061
b	0.330	0.510	0.013	0.020
c	0.170	0.250	0.006	0.010
D	4.700	5.100	0.185	0.200
D1	3.100	3.500	0.122	0.137
E	3.800	4.000	0.150	0.157
E1	5.800	6.200	0.228	0.244
E2	2.200	2.600	0.086	0.102
e	1.270(BSC)		0.050(BSC)	
L	0.400	1.270	0.016	0.050
Θ	0°	8°	0°	8°



# ACE621E

## Ultra-Fast High PSRR 1.5A CMOS Voltage Regulator

### Notes

ACE does not assume any responsibility for use as critical components in life support devices or systems without the express written approval of the president and general counsel of ACE Electronics Co., LTD. As used herein:

1. Life support devices or systems are devices or systems which, (a) are intended for surgical implant into the body, or (b) support or sustain life, and whose failure to perform when properly used in accordance with instructions for use provided in the labeling, can be reasonably expected to result in a significant injury to the user.
2. A critical component is any component of a life support device or system whose failure to perform can be reasonably expected to cause the failure of the life support device or system, or to affect its safety or effectiveness.

ACE Technology Co., LTD.  
<http://www.ace-ele.com/>